

P03

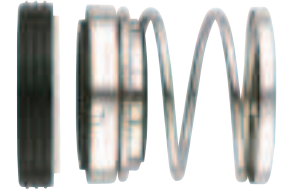

Stock code: N-P03-xxxx-xxxx



Rotary Face	Stationary Face	Elastomer	Build Code [^]
A - Carbon or D - Silicon Carbide (RB)	B - Alumina Ceramic or D - Silicon Carbide (RB)	X - Nitrile (BUNA) or Y - EPR (EPDM) or Z - Viton (FPM)	1 P

[^]Build Code 1 = Complete Seal, P = Rotary Only

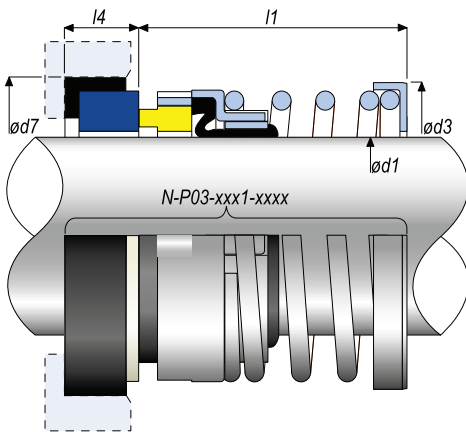

Size	d1		d3		d7		l1		l4	
	Metric	Imperial	Metric	Imperial	Metric	Imperial	Metric	Imperial	Metric	Imperial
0120	12.0	0.472	21.7	0.856	23.0	0.906	23.9	0.941	8.6	0.339
0140	14.0	0.551	24.0	0.945	25.0	0.984	26.4	1.039	8.6	0.339
0160	16.0	0.630	26.7	1.053	27.0	1.063	26.4	1.039	8.6	0.339
0180	18.0	0.709	30.5	1.201	33.0	1.299	27.5	1.083	8.6	0.339
0200	20.0	0.787	33.5	1.319	35.0	1.378	27.5	1.083	10.0	0.394
0220	22.0	0.866	33.5	1.319	37.0	1.457	27.5	1.083	10.0	0.394
0240	24.0	0.945	38.0	1.496	39.0	1.535	30.0	1.181	10.0	0.394
0250	25.0	0.984	39.5	1.555	40.0	1.575	30.0	1.181	10.0	0.394
0280	28.0	1.102	42.0	1.654	43.0	1.693	32.5	1.280	10.0	0.394
0300	30.0	1.181	44.0	1.732	45.0	1.772	32.5	1.280	10.0	0.394
0320	32.0	1.260	46.0	1.811	48.0	1.890	32.5	1.280	10.0	0.394
0330	33.0	1.299	46.0	1.811	48.0	1.890	32.5	1.280	10.0	0.394
0350	35.0	1.378	49.0	1.929	50.0	1.969	32.5	1.280	10.0	0.394
0380	38.0	1.496	53.0	2.087	56.0	2.205	34.0	1.339	11.0	0.433
0400	40.0	1.575	56.0	2.205	58.0	2.283	34.0	1.339	11.0	0.433
0430	43.0	1.693	58.8	2.314	61.0	2.402	34.0	1.339	11.0	0.433
0450	45.0	1.772	61.0	2.402	63.0	2.480	34.0	1.339	11.0	0.433
0480	48.0	1.890	64.0	2.520	66.0	2.598	34.0	1.339	11.0	0.433
0500	50.0	1.969	66.0	2.598	70.0	2.756	34.5	1.358	13.0	0.512
0530	53.0	2.087	70.7	2.780	73.0	2.874	34.5	1.358	13.0	0.512
0550	55.0	2.165	71.7	2.825	75.0	2.953	34.5	1.358	13.0	0.512
0580	58.0	2.283	79.6	3.134	78.0	3.071	39.5	1.555	13.0	0.512
0600	60.0	2.362	78.5	3.091	80.0	3.150	39.5	1.555	13.0	0.512
0630	63.0	2.480	81.5	3.209	83.0	3.268	39.5	1.555	13.0	0.512
0650	65.0	2.559	84.5	3.327	85.0	3.346	39.5	1.555	13.0	0.512
0680	68.0	2.677	89.7	3.533	90.0	3.543	37.2	1.465	15.3	0.602
0700	70.0	2.756	89.7	3.533	92.0	3.622	44.7	1.760	15.3	0.602
0750	75.0	2.953	97.0	3.819	97.0	3.819	44.7	1.760	15.3	0.602
0800	80.0	3.150	104.0	4.094	105.0	4.134	44.3	1.744	15.7	0.618



P04



Stock code: N-P04-xxxx-xxxx

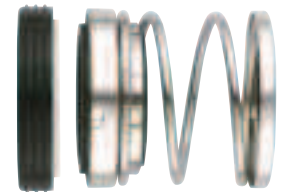

Rotary Face	Stationary Face	Elastomer	Build Code [^]
A - Carbon or D - Silicon Carbide (RB)	B - Alumina Ceramic or D - Silicon Carbide (RB)	X - Nitrile (BUNA) or Y - EPR (EPDM) or Z - Viton (FPM)	1 P

[^]Build Code 1 = Complete Seal, P = Rotary Only

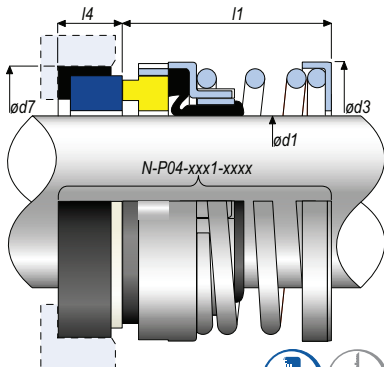

Size	d1		d3		d7		l1		l4	
	Metric	Inches	Metric	Inches	Metric	Inches	Metric	Inches	Metric	Inches
0127	12.7	0.500	24.0	0.945	25.4	1.000	20.6	0.812	7.9	0.312
0158	15.8	0.625	26.7	1.053	31.7	1.250	22.2	0.875	10.3	0.405
0191	19.1	0.750	31.2	1.230	34.9	1.375	22.2	0.875	10.3	0.405
0222	22.2	0.875	33.5	1.319	38.1	1.500	23.8	0.937	10.3	0.405
0254	25.4	1.000	43.2	1.703	41.2	1.625	25.4	1.000	11.1	0.437
0286	28.6	1.125	46.5	1.831	44.4	1.750	26.9	1.062	11.1	0.437
0317	31.7	1.250	49.5	1.949	47.6	1.875	26.9	1.062	11.1	0.437
0349	34.9	1.375	52.7	2.077	50.8	2.000	28.5	1.125	11.1	0.437
0381	38.1	1.500	56.0	2.205	53.9	2.125	28.5	1.125	11.1	0.437
0412	41.2	1.625	62.2	2.451	60.3	2.375	34.9	1.375	12.7	0.500
0444	44.4	1.750	66.0	2.598	63.5	2.500	34.9	1.375	12.7	0.500
0476	47.6	1.875	66.0	2.598	66.6	2.625	38.1	1.500	12.7	0.500
0508	50.8	2.000	73.0	2.874	69.8	2.750	38.1	1.500	12.7	0.500
0539	53.9	2.125	73.5	2.894	76.2	3.000	42.8	1.688	14.2	0.562
0571	57.1	2.250	79.6	3.133	79.3	3.125	42.8	1.688	14.2	0.562
0603	60.3	2.375	82.0	3.228	82.5	3.250	46.0	1.812	14.2	0.562
0635	63.5	2.500	85.0	3.346	85.7	3.375	46.0	1.812	14.2	0.562
0666	66.6	2.625	88.5	3.484	85.7	3.375	49.2	1.937	15.9	0.625
0698	69.8	2.750	92.7	3.652	88.9	3.500	49.2	1.937	15.9	0.625
0730	73.0	2.875	95.0	3.740	95.2	3.750	52.3	2.062	15.9	0.625
0762	76.2	3.000	102.0	4.016	98.4	3.875	52.3	2.062	15.9	0.625

