

CATALOGO R02
R02-CATALOGUE
R02-KATALOG



L'esperienza al servizio dell'innovazione

IT

Dal 1955 il Gruppo Varvel progetta e realizza sistemi di trasmissione di potenza impiegati in numerosi settori dell'industria. "Know-how to do it": Varvel ha le competenze per soddisfare al meglio le richieste dei clienti. Grazie alla grande esperienza maturata in oltre sessant'anni, Varvel offre alla clientela un'ampia gamma di soluzioni standard e prodotti personalizzati per esigenze specifiche. L'intera gamma di prodotti Varvel è progettata e realizzata in Italia, ma il Gruppo è presente in tutto il mondo con due filiali (una in USA e l'altra in India) e una rete globale con oltre 100 partner commerciali.

Experience at the service of innovation

EN

The Varvel Group has been designing and producing power transmission systems for numerous areas of industry since 1955. "Know-how to do it": Varvel has the know-how needed to satisfy customers' requests in the best way possible. Thanks to over sixty years of accumulated experience, Varvel can offer customers a vast range of standard solutions and customise products for specific needs. The entire product range is designed and made in Italy and sold worldwide through two subsidiaries (in the USA and India) and a global network of over 100 commercial partners.

Erfahrung im Dienste der Innovation

DE

Die Varvel-Gruppe entwickelt und produziert seit 1955 Kraftübertragungssysteme für viele Industriezweige. "Know-how to do it": Varvel verfügt über das Know-how, um die Anforderungen der Kunden bestmöglich zu erfüllen. Dank der in über sechzig Jahren Firmenaktivität gesammelten Erfahrung kann Varvel seinen Kunden eine breite Palette von Standardlösungen und maßgeschneiderten Produkten für alle spezifischen Anforderungen bieten. Die gesamte Varvel-Produktpalette wird in Italien entwickelt und hergestellt; darüber hinaus ist die Gruppe aber auch weltweit mit zwei Tochtergesellschaften (die eine in den USA und die andere in Indien) und einem globalen Netzwerk mit über 100 Geschäftspartnern präsent.

UNI EN ISO 9001:2015
UNI EN ISO 14001:2015
BS OHSAS 18001:2007



EC DIRECTIVE 2014/34/EC (ATEX)



RO-2

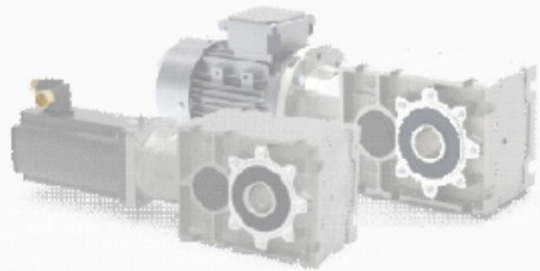

Riduttori ad assi ortogonali

- carcassa monoblocco
- due coppie di ingranaggi
- versione in linea
- motori IEC e NEMA

Bevel helical gearboxes

- one-piece housing
- two gear trains
- in-line version
- IEC and NEMA motors

Kegelradgetriebe

- Monoblockgehäuse
- Zweistufig
- In-Linie Ausführung
- IEC- u. NEMA-Motoren

INDICE

CONTENTS

INDEX



Sistema modulare	Modular System	Modularsystem	2
Catalogo elettronico	Electronic catalogue	Elektronischer Katalog	3
Informazioni tecniche	Technical information	Technische Informationen	
Descrizione	Description	Beschreibung	4-7
Giunto	Coupling	Kupplung	8
Flange & Giunto	Flanges & coupling	Flansch u. Kupplung	9
Designazione	Designation	Bezeichnung	10
Pesi, Quantità olio	Weights, Oil quantity	Gewichte, Ölmenge	11
Posizioni di montaggio	Mounting positions	Einbaulage	11
Lubrificazione	Lubrication	Schmierung	12
Apparenti perdite di olio	Apparent oil leakages	Scheinbare Öllecks	12
Fattori di servizio	Service factors	Betriebsfaktoren	13-14
Carichi esterni	External loads	Äußere Belastungen	15
Versioni	Versions	Ausführungen	16
Potenza termica	Thermal power	Thermische Nennleistung	17
Tabelle di Selezione	Selection tables	Auswahltabelle	
Riduttori FRO - SRO - RO	Gearboxes FRO - SRO - RO	Getriebe FRO - SRO - RO	18-19
Motoriduttori MRO	Geared motors MRO	Getriebemotoren MRO	20-35
Dimensioni	Dimensions	Abmessungen	
MRO - FRO - SRO - RO	MRO - FRO - SRO - RO	MRO - FRO - SRO - RO	36-51
Alberi uscita	Output shafts	Ausgangswellen	52-54
Posizione accessori	Accessory position	Position der Zubehör	55
Informazioni generali	General information	Allgemeine Informationen	
Parti componenti	Component parts	Bauelemente	56
Rotazione	Rotation	Drehrichtung	56
Motori IEC	IEC Motors	IEC-Motoren	57
ATEX	ATEX	ATEX	58-59
Uso e Manutenzione	Operation and Maintenance	Betriebs u. Wartungsanweisung	60

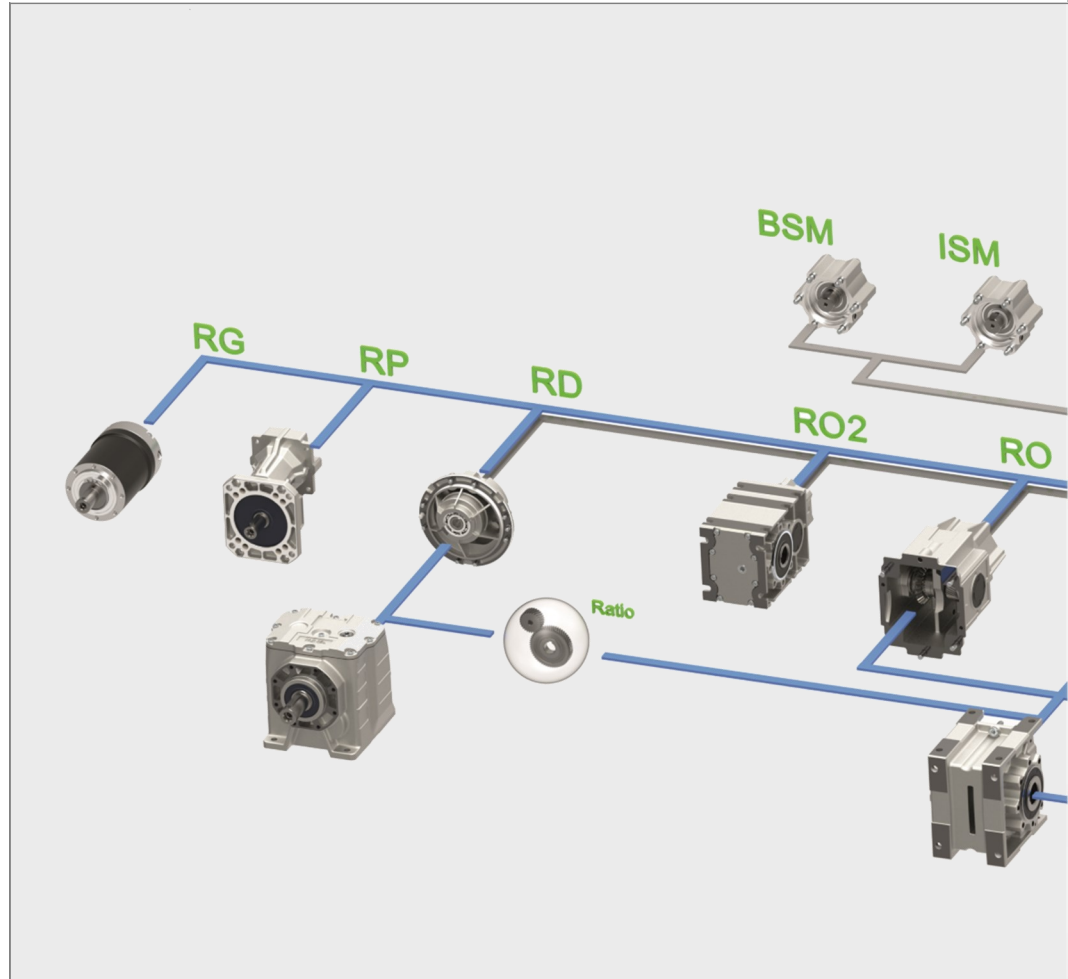

Modularità - Modularity - Modularität

A partire dagli anni 2000, il progetto dei prodotti VARVEL ha posto l'accento sulla modularità e la flessibilità, permettendo così alla rete di vendita di montare riduttori da kit in pochi minuti con attrezzature standard.

Grazie al montaggio in kit, i distributori e i rivenditori VARVEL beneficiano di una grande flessibilità, che consente loro di configurare il prodotto richiesto al più presto.

Since the 2000s, the VARVEL product design has focused on modularity and flexibility, allowing the sales network to assemble kit gearboxes in minutes with standard equipment.

Kit mounting provides VARVEL distributors and resellers with great flexibility, allowing them to configure the required product as soon as possible.

Modularität und Flexibilität sind seit den Jahren 2000 führend bei der Entwicklung von VARVEL-Produkten, indem sie unserem Vertriebsnetz die Montage von Getrieben in Bausatzform in wenigen Minuten und mit normaler Ausrüstung ermöglichen.

Die Kit-Zusammenstellung bietet VARVEL-Händlern und Wiederverkäufern maximale Flexibilität, die dank einer begrenzten Verfügbarkeit von Bausätzen sofort das erforderliche Produkt konfigurieren können.

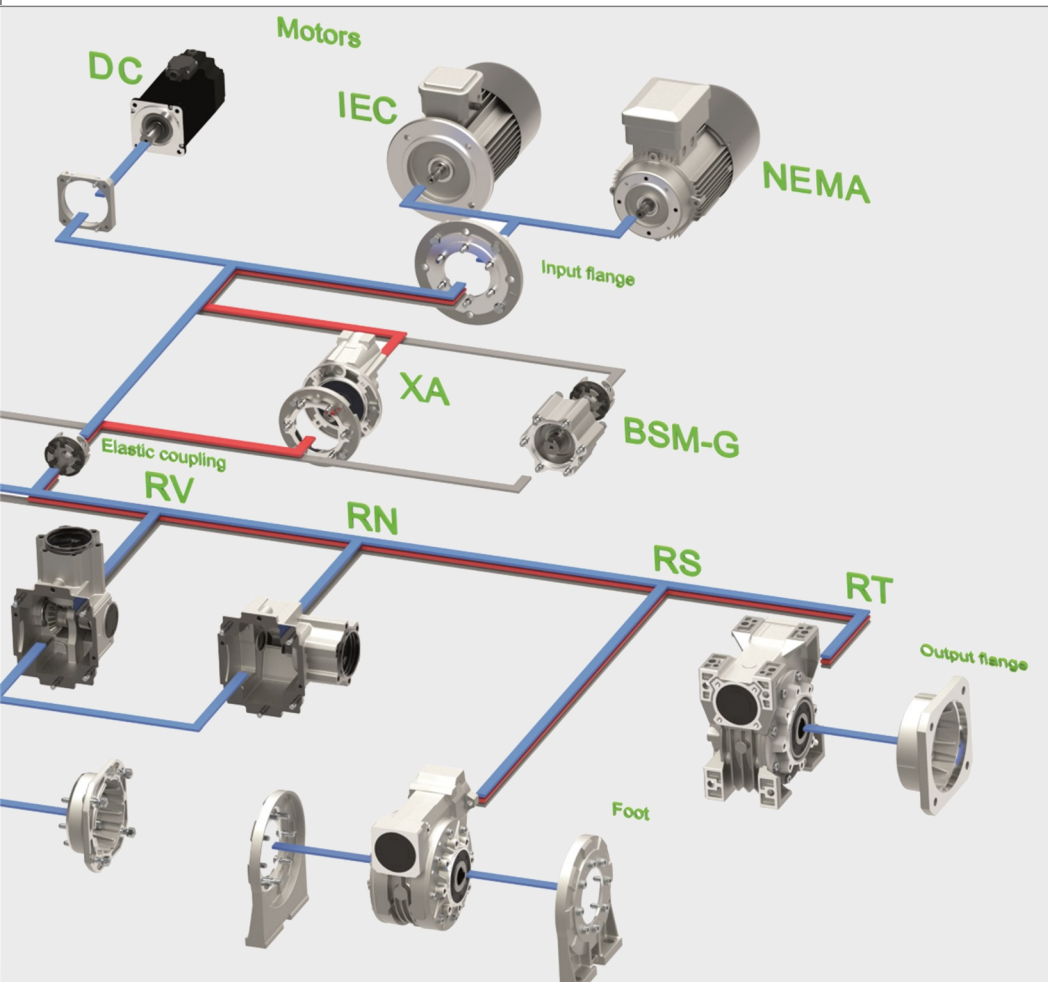

Catalogo elettronico - Electronic catalogue - Elektronischer Katalog



Il programma di selezione **VARsize**® disponibile nel sito www.varvel.com permette un facile dimensionamento dei prodotti VARVEL.

Disegni 2D/3D

Tramite configurazione assistita si generano modelli 3D e disegni 2D nei formati CAD più diffusi.

Configurazione assistita

VARsize identifica

- i riduttori che soddisfano i parametri di funzionamento richiesti (potenza, coppia, velocità, fattore di servizio, ecc.),
- un documento dei dati caratteristici del riduttore selezionato,
- il disegno dimensionale 2D,
- il modello 3D.

VARsize® selection program, available from our site www.varvel.com allows a friendly sizing of VARVEL product range.

2D/3D Drawings

A guided selection lets 2D/3D models downloaded for the most popular CAD systems.

Guided selection

VARsize returns

- the gearboxes matching the required operation parameters (power, output torque, rpm, service factor etc.),
- a data sheet featuring performance data of the selected gearbox;
- the 2D dimensional drawings,
- the 3D model.

Das **VARsize**® Auswahlprogramm finden Sie auf der Website www.varvel.com ermöglicht die einfache Dimensionierung von VARVEL-Produkten .

2D/3D-Zeichnungen

Die unterstützte Auswahl bietet die Möglichkeit 2D/3D Modelle für die gängigen CAD Systeme zu laden.

Unterstützte Auswahl

VARsize erzeugt

- die Getriebe der erforderlichen Betriebsparameter für: Leistung, Moment, Drehzahl, Betriebsfaktor usw.,
- ein Datenblatt mit die charakteristischen Daten des gewählten Getriebe,
- die 2D-Maßzeichnung,
- das 3D-Modell.

Descrizione Description Beschreibung

I riduttori ortogonali a due coppie, Serie RO-2, sono costruiti con carcassa integrale, ingranaggi conici all'entrata ed una coppia cilindrica in uscita per sopportare importanti carichi esterni.

La Serie RO-2 è concepita secondo le norme di progettazione ISO con l'ausilio di analisi strutturale per verifica della deformata e dello stress della carcassa.

La robusta struttura monolitica non subisce deformazioni sotto effetto della coppia di funzionamento e dei carichi esterni con positivi risultati sulle superfici di tenuta.

La versione pendolare permette la conversione in forma flangiata B5 applicando semplicemente una delle diverse flange di uscita disponibili.

Diverse dimensioni e tipi di alberi di uscita (cavo con chiavetta in esecuzione standard o a richiesta con serraggio a calettatore o scanalato e pieno con una o due sporgenze) sono disponibili per la più ampia possibilità di applicazioni.

La serie RO-2 è disponibile in 4 grandezze, 17 rapporti e momenti torcenti fra 120 e 500 Nm.

Potenza termica

La potenza nominale è la potenza che può essere applicata all'entrata del riduttore, in servizio continuo, temperatura max. ambiente di 40 °C, altitudine max. 1000 m, senza superare una temperatura dell'olio di circa 85 °C.

La potenza termica può limitare la potenza nominale in funzione del sistema di raffreddamento, della velocità di entrata, della temperatura ambiente e del coefficiente di servizio.

Paraoli

- NBR - montati su alberi entrata e uscita, come standard,
- Viton - montati per funzionamento con motori 2-poli AC, DC e servo, a richiesta.
- Silicone - montati per funzionamento a basse temperature, a richiesta.

Integral casing, input bevel and output cylindrical gears to afford significant external loads are the features of the RO-2 Series two-stage orthogonal gearboxes .

The RO-2 Series is designed according to ISO design standards using structural analysis to verify the deformation and stress of the housing.

Operating torque and external loads do not cause the robust monolithic structure to deform, leading to positive results on the sealing surfaces.

By simply applying one of the different output flanges available, the shaft mount version can be converted to B5 flange form.

Output shafts of different sizes and types (hollow with keyway in standard version, and on request with shrink-disk clamping, throughout splined, and with one or two solid extensions) are available for a wide range of applications.

Four sizes, 17 ratios, and a torque range of 120 to 500 Nm are available for the RO-2 series.

Thermal power

The rated power is the power that can be applied to the input of the gearbox, on continuous service, max. room temperature of 40 °C, max. altitude 1000 m, without exceeding an oil temperature of about 85 °C.

The thermal power can limit the rated power depending on the cooling system, the input speed, the ambient temperature and the service factor.

Oil seals

- NBR - fitted on input and output shafts as standard.
- Viton - for operation with 2-pole AC, DC and servo motors, on demand.
- Silicone - for low temperature operation, on demand.

Die zweistufigen Kegelstirnradgetriebe der Serie RO-2 wurden aus einem Guss, kompakten und robusten einteiligen Gehäusen mit Eingangs- Kegelradstufe und Ausgangs- Stirnradstufe konzipiert, um erhebliche externen Belastungen standzuhalten.

Die Baureihe RO-2 ist nach den ISO-technischen Spezifikationen mit Unterstützung einer computergestützten Strukturanalyse zur Verformung und Kräfteeinwirkung entwickelt worden.

Das einteilige Gehäuse wird weder durch die Einwirkung des Drehmoments noch der Wirkkraft externer Lasten in Bezug der Dichtflächen beeinflusst.

Die Aufsteckversion ermöglicht eine Umsetzung in B5-Flanschbefestigung durch einen einfachen Anbau der vielen unterschiedlichen Abtriebsflansch.

Verschiedene Größen und Arten an Abtriebswellen (Hohlwelle mit Nut, mit Schrumpfscheibe oder mit Keilprofil und als Vollwelle als einseitige oder doppelseitige Ausführung) stehen für die Mehrzahl der Anwendungen zur Verfügung.

Die RO-2-Serie wird in 4 Größen, 17 Untersetzungen und Abtriebsdrehmoment zwischen 120 und 500 Nm gefertigt

Thermische Leistung

Die Nennleistung ist die Leistung, die am Getriebe angewendet werden kann, Dauerbetriebstemperatur von 40 °C, max. Höhe 1000 m ohne, mehr als eine Temperatur von Öl von etwa 85 °C.

Die thermische Leistung kann der Nennleistung P_1 als Funktion des Kühlsystems der Antriebsdrehzahl, Umgebungstemperatur und der Koeffizient der Service begrenzen.

Dichtringe

- NBR - werden als Standard an den Ein- und Ausgangswellen montiert.
- Viton - für Betrieb mit 2-Pole AC, DC und Servomotoren, auf Anfrage.
- Silikon - für niedrige Temperaturen, auf Anfrage.



Lubrificante

I riduttori sono forniti riempiti di olio sintetico a lunga durata (ISO VG 320) per temperature -15/+35 °C.

Le quantità d'olio sono valide per le diverse posizioni di montaggio. Tappi olio e di sfiato sono forniti su richiesta.

Fattore di servizio

I dati di selezione sono intesi per un fattore di servizio SF1.0, cioè

- 8 ore di funzionamento al giorno
- carico uniforme
- Max. 6 avviamenti all'ora
- temperatura ambiente fra 15 a 35 °C.

Informazioni più dettagliata alla pagina 13.

Direttiva ATEX

I riduttori VARVEL-ATEX, forniti su richiesta, sono costruiti secondo la Direttiva Europea 2014/34/UE-ATEX e pertanto, sono qualificati per installazione in atmosfere potenzialmente esplosive. Dettagliate informazioni alle pagine 58-59.

Protezioni superficiali

- verniciatura a liquido: fondo in vernice epossidica bicomponenti e finitura con smalto poliuretano bicomponente.
- verniciatura bianca RAL 9010 per ambienti alimentari senza contatto diretto con gli alimenti: fondo in vernice epossidica bicomponenti e finitura acrilica bicomponente a base di resine acriliche ossidrilate ed addotto isocianico alifatico.
- anodizzazione nera secondo ISO 10681
- fluotitanazione (Cr-free conversione)

Dimensioni

Le dimensioni e le unità di misura sono riferite al sistema metrico, o imperiale quando specificato.

Lubricant

Gearboxes are delivered filled with synthetic long-life oil (ISO VG 320 Grade) for temperature -15/+35 °C as standard. Oil quantities are valid for any working positions. Lubrication-for-life is factory packed.

Oil, drain or vent plugs on demand.

Service factor

Selection data are intended for service factor SF1.0. i.e.

- 8 running hours per day,
- uniform load,
- max. 6 start/stops per hour and
- room temperature from 15 to 35 °C.

More detailed information on page 13.

Directive ATEX

The gearboxes VARVEL-ATEX, supplied on demand, are manufactured according to the European Directive 2014/34/UE-ATEX and therefore, they are qualified for installation in potentially explosive atmospheres.

Detailed information at pages 58-59.

Surface protection

- liquid painting: two-component epoxy paint primer and two-component polyurethane enamel finish.
- white paint RAL 9010 for food environments without direct contact with food: a primer with two-component epoxy paint and two-component acrylic finish based on hydroxylated acrylic resins and aliphatic isocyanic adduct.
- black anodising according to ISO 10681
- fluorination (Cr-free conversion)

Dimensions

Dimensions and units of measurement are referred to metric system, or imperial where applicable

Schmierung

Die Getriebe werden mit langlebigem synthetischem Öl (ISO VG 320) für Temperaturen bei -15/+35 °C beliefert.

Die Ölmenge gilt für verschiedene Montagepositionen.

Öl- und Entlüftungsventile sind auf Anfrage erhältlich.

Betriebsfaktor

Die Auswahldaten sind für einen SF1.0-Leistungsfaktor bestimmt, d.h.

- 8-Stunden pro Tag an Betriebsdauer
- gleichmäßige Belastung
- max. 6 Starts pro Stunde
- Raumtemperatur zwischen 15 und 35°C.

Detailliertere Informationen auf der Seite 13.

Richtlinie ATEX

VARVEL-ATEX-Getriebe, die auf Anfrage geliefert werden, sind gemäß der Europäischen Richtlinie 2014/34/EU-ATEX gebaut und daher für den Einbau in explosionsfähige Atmosphären qualifiziert.

Detaillierte Informationen auf den Seiten 58-59.

Oberflächenschutz

- Flüssiglackierung: Boden aus zwei-Komponenten Epoxidlack und Oberfläche aus zwei-Komponenten Polyurethanlack.
- Weißlack RAL 9010 für Lebensmittelumgebungen ohne direkten Kontakt mit Lebensmitteln: Grundierung mit Zweikomponenten-Epoxidlack und Zweikomponenten Acrylbeschichtung auf Basis von hydroxylierten Acrylharzen und aliphatischen Isocyanat.
- schwarz eloxiert nach ISO 10681
- Fluotitanierung (Cr-freie Umwandlung)

Dimensionen

Die Abmessungen und Maßeinheiten beziehen sich auf das metrische System, oder imperiale wenn angegeben.



Descrizione
Description
Beschreibung

Specifiche generali - General specifications - Allgemeine Eigenschaften

Gamma Range Bereich	2 4 17 500	copie di ingranaggi grandezze rapporti di riduzione Nm coppia uscita max.	2 4 17 500	gear stages sizes reduction ratios Nm max. output torque	2 4 17 500	Zahnradstufen Baugrößen Übersetzungen Nm max. Abtriebsmoment
Dimensionamento Sizing Auslegung	secondo ISO6336/DIN3990		according to ISO6336/DIN3990		nach ISO6336 / DIN3990	
Carcassa Housing Gehäuse	monoblocco, pressofusione in alluminio		pressure die cast aluminium monoblock		Monoblock, Aluminium-Druckguss	
Giunto Coupling Kupplung	pressofusione in alluminio acciaio, a richiesta		pressure die cast aluminium steel, on demand		Aluminium-Druckguss Stahl, auf Anfrage	
Parti dentate Toothed parts Verzahnung	evolvente rettificato/sbarbato coppie coniche rodiate		tooth profile ground/shaved run-in bevel gears		Zahnprofil geschliffen/rasiert Kegelräder eingelaufen	
Cuscinetti Bearings Lagerung	sfere o rulli secondo grandezza		ball- or roller-types according to sizes		Kugel- oder Rollenlager nach Größe	
Paraolio Oil seals Dichtungen	NBR - standard VI - Viton a richiesta SI - Silicone a richiesta		NBR - standard VI - Viton on demand SI - Silicone on demand		NBR - Standard VI - Viton auf Anfrage SI - Silikon auf Anfrage	
Lubrificante Lubricant Schmierung	olio sintetico a lunga durata gradazione ISO VG 320		synthetic long-life oil grade ISO VG 320		Synthetisches Langzeit-Öl ISO VG 320	
Superfici esterne External surfaces Außenflächen	alluminio naturale, non verniciato		natural aluminium, unpainted		Aluminium Natur, nichtlackiert	
Grado di protezione Protection grade Schutzgrad	IP66 - corpo del riduttore IP20 - riduttore con flange protezioni aumentate a richiesta		IP66 - gearbox body only IP20 - gearbox with flanges increased grades on demand		IP66 - Nur Getriebesgehäuse IP20 - Getriebe mit Flansche Schutzart erhöht nach Anfrage	
ATEX	a richiesta		on demand		auf Anfrage	

Simboli - Symbols - Zeichen

Fr_1, Fr_2, Fr [N]	carico radiale (entrata, uscita, applicazione)	radial load (input, output, application)	Radialbelastung (Eingang, Ausgang, Verwendung)
Fa_2 [N]	carico assiale (uscita)	axial load (output)	Axialbelastung (Ausgang)
SF SF ₁ SF ₂	fattore di servizio FS per tipo di carico FS per avviamenti/ora	service factor SF by load type SF by starts per hour	Betriebsfaktor SF nach Belastungstyp SF nach Schaltungen/St.
i, i_r	rapporto di riduzione (nominale, reale)	reduction ratio (nominal, real)	Übersetzung (nominale, reelle)
J_1, J_2, J_m [kgm ²]	momento d'inerzia del riduttore (entrata, uscita) e del motore	moment of inertia of the gearbox (input, output) and of motor	Trägheitsmoment des Getriebes (Eingang, Ausgang) u. des Motor
K_a, K_L, K_T, K_{S3}	fattore (accelerazione, lunghezza, tipo, intermittenza S3)	factor (acceleration, length, type, S3 intermittence)	Faktor (Beschleunigung, Länge, Typ, S3-Intermittenz)
H, V	montaggio (orizzontale, verticale)	mounting (horizontal, vertical)	Einbaulage (waagrechte, senkrechte)
Lub [litri, litres. Liter]	lubrificante	lubricant	Schmierstoff
$M_2, M_{(app)}$ [Nm]	coppia massima di uscita (riduttore, applicazione)	maximum output torque (gearbox, application)	Abtriebsdrehmoment (Getriebe, Verwendung)
η	rendimento	efficiency	Wirkungsgrad

Formule utili - Useful formulae - Nützliche Formeln

Potenza entrata Input power Eingangsleistung [kW]	Coppia uscita Output torque Ausgangsdrehmoment [Nm]	Fattore di utilizzo Duty factor Nutzungsfaktor [FU]
$P_1 = \frac{M_2 * n_2}{9550 * \eta}$	$M_2 = \frac{9550 * P_1 * \eta}{n_2}$	$FU = \frac{M_2}{M_{(app)}}$

Giunto Coupling Kupplung

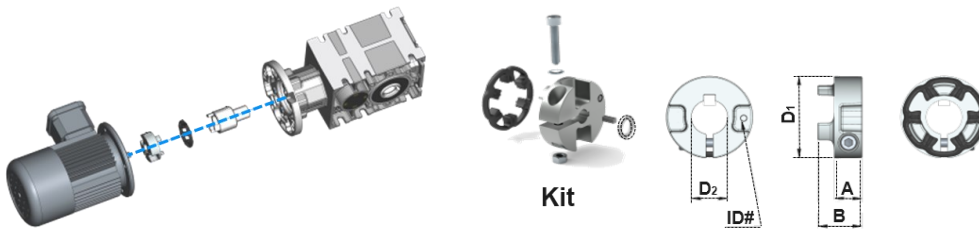

Kit

Giunto a morsetto serrato sull'albero motore

- Flange e giunti per motori IEC, NEMA, Brushless, c.c. montabili sul riduttore finito
- Eliminazione sfregamento fra foro e chiave (tribocorrosione)
- Gioco zero nel collegamento riduttore/ motore
- Elevata rigidità torsionale

Jaw-coupling clamped on the motor shaft

- IEC, NEMA, Brushless, DC adapters and couplings to fit on already assembled gearbox
- Elimination of fretting corrosion between bore and key
- Zero backlash in gearbox/ motor connection
- High torsional rigidity

Kupplung mit Reibungsklemmung auf dem Motorwelle

- IEC-, NEMA-, Brushless-, Gleichstrom-Flanschen und Kupplungen auf dem fertigem Getriebe montierbar
- Vermeidung von Passungsrost zwischen Bohrung u. Keil
- Getriebe / Motor Spielfrei Verbindung
- Hohe Verdrehsteifigkeit

Tipo Type Typ	Codice Kit Kit Part No. Kit Teil Nr.	RO	Mt [Nm]	Mt ₁ [Nm]	Mt ₂ [Nm]	A [mm]	B [mm]	D ₁ [mm]	D ₂ [mm]	ID#
G5	KG5.009	02	8.9 - 10	14	8 - 10	14.5	23	45	9	509
	KG5.011			15	8 - 10			45	11	511
	KG5.014			30	12 - 17			45	14	514
	KG5.019			40	20 - 25			45	19	519
	KG5.024			70	30 - 40			52	24	524
G6	KG6.014	12 - 22 - 32	15.3 - 18	60	30 - 40	19.5	31.5	58	14	614
	KG6.019			90	50 - 65			19	619	
	KG6.024			130	85 - 100			24	624	
	KG6.028			180	100 - 120			28	628	
	KGS6.038			500	---			38	---	



Tipo Type Typ	Codice Kit Kit Part No. Kit Teil Nr.	RO - RV	Mt [in-lb]	Mt ₁ [in-lb]	Mt ₂ [in-lb]	A [in]	B [in]	D ₁ [in]	D ₂ [in]	ID#
G5	KG5.N56	02	80 - 90	400	265 - 310	0.57	0.91	1.77	1/2"	5N48
	KG5.N140			530	355 - 400			2.05	5/8"	5N56
G6	KG6.N56	12 - 22 - 32	135 - 160	440	---	0.77	1.24	2.28	5/8"	6N56
	KG6.N140			750	---			7/8"	6N140	
	KG6.N180			1770	---			1-1/8"	6N180	



Mt - coppia di serraggio vite
Mt₁ - coppia trasmissibile con chiave
Mt₂ - coppia trasmissibile senza chiave

Mt - screw locking torque
Mt₁ - transmissible torque with key
Mt₂ - transmissible torque without key

Mt - Klemmendrehmoment der Schraube
Mt₁ - übertragbar Drehmoment mit Keil
Mt₂ - übertragbar Drehmoment ohne Keil

Tipo Type Typ	Flangia - Flange - Flansch				Giunto - Coupling - Kupplung		Flange e Giunto Flanges & Coupling Flansche u. Kupplung
	Tipo - Type - Typ	IEC	Codice - Part No. - Teil Nr. Kit B5 Kit B14		Tipo - Type - Typ	Kit Part No.	
RO02	FM 50	IEC56 IEC63 IEC71 IEC80 IEC90	K532.206.120 K532.206.140 K532.206.160 K532.206.200 K532.206.200	--- K532.206.090 K532.206.105 K532.206.120 K532.206.140	G5 ø9 G5 ø11 G5 ø14 G5 ø19 G5 ø24	KG5.009 KG5.011 KG5.014 KG5.019 KG5.024	
RO12	FM 70	IEC63 IEC71 IEC80 IEC90 IEC100/112	K533.206.140 K533.206.160 K533.206.200 K533.206.200 K533.206.250	--- K533.206.105 K533.206.120 K533.206.140 K533.206.160	○ ø11 G6 ø14 G6 ø19 G6 ø24 G6 ø28	○ ø11 KG6.014 KG6.019 KG6.024 KG6.028	
RO22	FM 85	IEC63 IEC71 IEC80 IEC90 IEC100/112	K534.206.140 K534.206.160 K534.206.200 K534.206.200 K534.206.250	--- --- K534.206.120 K534.206.140 K534.206.160	○ ø11 G6 ø14 G6 ø19 G6 ø24 G6 ø28	○ ø11 KG6.014 KG6.019 KG6.024 KG6.028	
RO32	FM 110	IEC71 IEC80 IEC90 IEC100/112 IEC132	K535.206.160 K535.206.200 K535.206.200 K535.206.250 K535.206.300	--- --- --- K535.206.160 K535.206.200	G6 ø14 G6 ø19 G6 ø24 G6 ø28 ○ ø38	KG6.014 KG6.019 KG6.024 KG6.028 ---	

○ ø.. - foro con cava chiavetta
(nessun giunto)

○ ø.. - bore with keyway
(no coupling)

○ ø.. - Bohrung mit Keilriemen
(keine Kupplung)

Tipo Type Typ	Flangia - Flange - Flansch			Giunto - Coupling - Kupplung	
	Tipo - Type - Typ	NEMA	Kit Part No.	Tipo - Type - Typ	Kit Part No.
RO02	FM 50	56 C 140 TC	K532.227.N56	G5 ø5/8" G5 ø7/8"	KG5.N56/X KG5.N140/X
RO12	FM 70	56 C 140 TC	K533.227.N56	G6 ø5/8" G6 ø7/8"	KG6.N56/X KG6.N140/X
RO22	FM 85	56 C 140 TC	K534.227.N56	G6 ø5/8" G6 ø7/8"	KG6.N56/X KG6.N140/X
RO32	FM 110	56 C 140 TC 180 TC	K535.227.N56 K535.227.N56 K535.227.N180	G6 ø5/8" G6 ø7/8" G6 ø1-1/8"	KG6.N56/X KG6.N140/X KG6.N180/X



**Designazione
Designation
Bezeichnung**

Riduttore - Gearbox - Getriebe

F	RO	-G ---	12	/B3	H	18	IEC71	B14	AU30	DFU200
										Flangia uscita - Output flange - Ausgangsflansch
										Albero uscita - Output shaft - Ausgangswelle
										Forma del motore - Motor form - Motorbauform
										Grandezza del motore elettrico - Electric motor frame - Motorbaugröße
										Rapporto di riduzione - Reduction ratio - Getriebeübersetzung
										H, V = Posizione di montaggio - Mounting position - Einbaulage
										B3, B5, B3/B5 = Forma costruttiva - Gearbox form - Bauform
										Grandezza e coppie - Size and stages - Baugröße u. Stufen
										-G = Entrata con giunto G - Input with G-type coupling - Eingang mit G-Kupplung --- = Entrata foro e chiavetta - Bore and keyway input - Eingang mit Bohrung u. Keil
Tipo del riduttore - Gearbox type - Getriebetyp										

M = Motoriduttore	- Geared motor	- Getriebemotor
F = Riduttore con flangia entrata	- Gearbox with input flange	- Getriebe mit Eingangsflansch
S = Riduttore senza flangia entrata	- Gearbox without input flange	- Getriebe ohne Eingangsflansch
... = Riduttore con albero entrata	- Gearbox with input free shaft	- Freie Eingangswelle

Motore - Motor - Elektromotor

MT	0.37 kW	71 B	4	B14	230/400/50	IP55	F	X4
								Posizione della morsettiera Terminal box position Klemmkastenposition
								F (std) = Classe isolamento Insulation class Isolationsklasse
								IP55 (std) = Grado di protezione Protection class Schutzart
								Tensione / Frequenza - Voltage / Frequency - Spannung / Frequenz
								B5, B14 = Forma costruttiva - Mounting form - Bauform
								Numero poli - Number of poles - Polzahl
								Grandezza del motore (IEC) - Motor frame (IEC) - Motorbaugröße (IEC)
Potenza del motore - Motor power - Motorleistung								

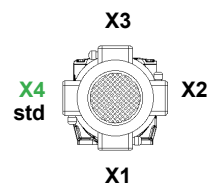

MT = Motore trifase	- Three-phase motor	- Dreiphasenmotor
MM = Motore monofase	- Single-phase motor	- Einphasenmotor
MA = Motore autofrenante	- Brake motor	- Bremsmotor

Pesi - **Posizione di montaggio**
Weights - **Mounting position**
Gewichte - **Montageposition**

Pesi e quantità olio - Weights and oil quantity - Gewichte u. Ölmengen

FRO SRO RO	Peso Weight Gewicht kg	ISO VG320 Olio [litri] - Oil [litres] - Öl [Liter]					
		H1	H2	H3	H4	V1	V2
02	4.4	0.4	0.2	0.3	0.2	0.4	0.3
12	7.0	0.7	0.4	0.6	0.4	0.7	0.5
22	11	1.0	0.7	0.9	0.7	1.1	0.8
32	15	1.5	1.0	1.3	1.0	1.5	0.9



RO-2

Posizione di montaggio - Mounting position - Montageposition

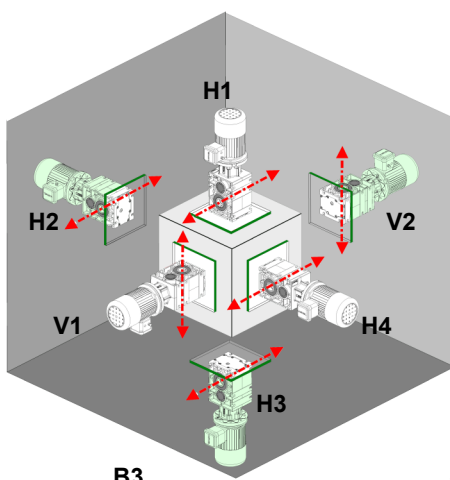

B3

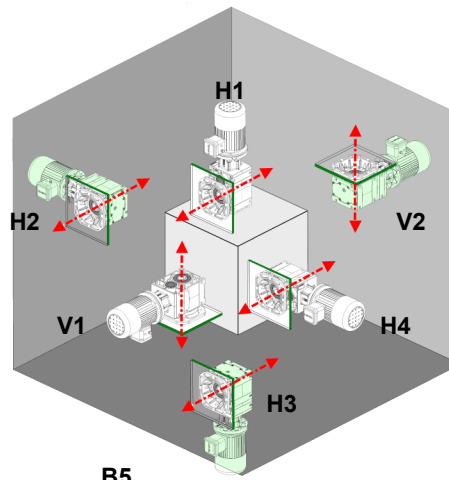

B5

Attenzione !
 La posizione di montaggio (H o V) è riferita alla posizione dell'albero di uscita e non alla posizione di fissaggio B3 con piedi o B5 con flangia.

Attention !
 Mounting position (H or V) is referred to the output shaft position and not to B3-foot or B5-flange fixing position.

Achtung !
 Die Montageposition (H oder V) bezieht sich auf die Ausgangs Welleposition und nicht der B3-Fuß- oder B5-Flanschbefestigungen.

Lubrificazione Lubrication Schmierung

Lubrificanti - Lubricants - Schmiermittel

										
	* Degol GS 320	Energyn SG-XP320	Alphasyn PG 320	Glycolube 320	Klübersynth GH-6-320	Glygoyle HE 320	Synlube CLP 320	Carter SY 320	Omalia S4 WE 320	
VG320	** Eural Gear 320	---	Vitalube GS 320	Gear Oil FM 320	Klübersynth UH1-6-320	Mobil DTE FM 320	---	Nevastane EP 320	---	

Tutti i riduttori sono spediti già riempiti con olio a base sintetica a lunga durata. La gradazione ISO VG 320 permette un corretto funzionamento nel campo di temperature ambiente fra -15 e +35 °C. Più basse o elevate temperature, impongono considerazioni ambientali da sottoporre al Servizio Clienti.

- * - olio sintetico
- ** - olio sintetico per Industria alimentare

All the units are delivered already filled with synthetic long-life oil. ISO VG 320 grade allows correct operation in the ambient temperature range between -15 and +35 °C (+60 and +95 °F). Lower or higher temperatures require environmental considerations to submit to Customer Service.

- * - synthetic base oil
- ** - Food Industry Approved synthetic oil

Alle Getriebe werden bereits mit langlebigem synthetischem Ölfüllung ausgeliefert. Die Schmiermittel ISO VG 320 ermöglicht einen reibungslosen Betrieb im Umgebungstemperaturbereich zwischen -15 u. +35 °C. Niedrigere oder höhere Temperaturen erfordern Umweltüberlegung, die dem Kundenservice vorgelegt werden müssen.

- * - Synthetisches Öl
- ** - Lebensmittel-verträgliche, synthetisches Öl

Apparenti perdite di olio - Apparent oil leakages - Scheinbare Öllecks

Il labbro del paraolio è protetto con apposito grasso per evitare che all'avviamento l'albero inizi a ruotare senza alcun lubrificante interposto e che non avvenga ossidazione della pista di scorrimento del labbro. La temperatura del labbro del paraolio aumenta durante il funzionamento; il grasso posto all'esterno fluidifica e la sua parte oleosa può essere riconosciuta erroneamente come olio proveniente dall'interno. Questa untuosità, come la pellicola lubrificante che è sempre presente fra paraolio e albero, possono essere giudicate a torto come perdite di lubrificante.

The oil seal lip is protected with a special grease to prevent the shaft rotation without any lubricant interposed at start-up and to protect oxidation of the oil seal lip track. The oil seal lip temperature increases during operation; the grease placed outside fluidizes and its oily part can be incorrectly recognized as oil coming from inside. This oiliness, like the lubricating film that is always present between the oil seal and the shaft, can be wrongly judged as a loss of lubricant.

Die Lippe der Öldichtung wird während der Montage mit einem speziellen Fett geschützt, um zu verhindern, dass sich die Welle beim Start ohne dazwischenliegendes Schmiermittel zu drehen beginnt und keine Oxidation der Lippengleitbahn auftritt. Die Temperatur der Öldichtungslippe steigt während des Betriebs an. Das außen angebrachte Fett wird dünner und sein öliger Teil kann fälschlicherweise als von innen kommendes Öl erkannt werden. Diese Fettigkeit kann wie der Schmierfilm, der immer zwischen der Öldichtung und der Welle vorhanden ist, fälschlicherweise als Schmiermittelverlust beurteilt werden.

Tappi di sfiato - Breather plugs - Entlüftungsventile

L'installazione del tappo di sfiato è raccomandato quando la pressione interna supera i valori di 0.25-0.3 bar per evitare possibili fuoriuscite di lubrificante dai paraolio. L'aumento della pressione interna è originata dalla variazione del volume del lubrificante causato dall'aumento dalla temperatura a fronte di condizioni esterne (posizione di lavoro inclinata, ambiente maggiore di 35 °C), o interne (velocità di ingresso maggiore di 2000 rpm, frequenti avviamenti, servizio continuo oltre a 8 ore al giorno).

The vent cap installation is recommended when the internal pressure exceeds the values of 0.25-0.3 bar to avoid possible leakage of lubricant from the oil seals. The increase in internal pressure is caused by the variation in lubricant volume caused by the temperature increase under external conditions (inclined working position, environment greater than 35 Celsius), or internal (input speed greater than 2000 rpm, frequent starts, continuous service over 8 hours a day).

Die Installation des Entlüftungsventil wird empfohlen, wenn der Innendruck 0.25-0.3 bar übersteigt, um ein Auslaufen von Schmiermitteln aus den Dichtungen zu vermeiden. Die Erhöhung des Innendrucks ergibt sich aus der Veränderung des Schmiervolumens verursacht unter bestimmten Temperatur Bedingungen, rein indikativ, wie äußerer Bedingungen (gekippte Arbeitsposition, Umgebung mehr als 35 °C), oder inneren Bedingungen (Eingangsgeschwindigkeit mehr als 2000 UpM, häufige Start ups, durchgehender Dienst mehr als 8 Stunden pro Tag).

Fattori di servizio Service factors Betriebsfaktoren

Fattore di utilizzo - Duty factor - Nutzungsfaktor

Il Fattore di utilizzo è definito dal rapporto fra la coppia massima di uscita M_2 del riduttore e la coppia richiesta dalla applicazione M_{app} . Il rapporto deve essere superiore o uguale ai fattori SF o $k_{(a)}$ qui descritti.

The ratio between the gearbox's maximum output torque M_2 and the M_{app} application's torque requirement defines the Duty factor. The ratio shall be greater than or equal to the SF or $k_{(a)}$ factors described here.

Der Nutzungsfaktor wird durch das Verhältnis zwischen dem maximalen M_2 -Ausgangsdrehmoment des Getriebes und dem von der Anwendung geforderten M_{app} -Drehmoment bestimmt. Das Verhältnis muss größer oder gleich als der hier definierte SF- oder $k_{(a)}$ -Faktoren sein.

$$FU = \frac{M_2}{M_{app}}$$

$$FU \geq SF$$

$$FU \geq k_{(a)}$$

FU - fattore di utilizzo
 M_2 - coppia max. del riduttore
 M_{app} - coppia della applicazione

FU - duty factor
 M_2 - max. torque of the gearbox
 M_{app} - torque of the application

FU - Nutzungsfaktor
 M_2 - max. Drehmoment des Getriebes
 M_{app} - max. Drehmoment der Anwendung

Fattore di servizio - Service factor - Betriebsfaktor

Il Fattore di servizio [SF1.0] è inteso come rappresentativo di un funzionamento di 8 ore al giorno, con carico uniforme, avviamenti inferiori a 6 all'ora e temperatura ambiente fra 15 e 35 °C.

Per altre condizioni di servizio, selezionare SF secondo le tabelle SF₁ e SF₂.

The Service factor [SF1.0] is intended to be representative of an operation of 8 hours per day, with a uniform load, starts of less than 6 per hour and ambient temperature between 15 and 35 Celsius.

For other service conditions, select SF according to tables SF₁ and SF₂.

Der Belastungsfaktor [SF1.0] gilt als repräsentativ für einen 8-stündigen Betrieb pro Tag bei gleichmäßiger Belastung, Startzeiten unter 6 pro Stunden und Umgebungstemperatur zwischen 15 und 35°C.

Für andere Betriebsbedingungen wählen Sie den SF-Faktor gemäß den Tabellen SF₁ und SF₂.

$$SF = SF_1 \times SF_2$$

SF ₁			
h	A	B	C
8	1.0	1.2	1.4
16	1.2	1.4	1.6
24	1.4	1.6	1.8

SF ₂	
n	RS - RT
6	1.0
60	1.1
120	1.2

SF - fattore di servizio
SF₁ - SF per tipo del carico
SF₂ - SF per avviamenti/ora
h - ore
A, B, C - tipo di carico (uniforme, variabile, a urti)
n - numero

SF - service factor
SF₁ - SF by load type
SF₂ - SF by starts per hour
h - hours
A, B, C - type of load (uniform, variable with shocks)
n - number

SF - Betriebsfaktor
SF₁ - SF nach Belastungstyp
SF₂ - SF nach Schaltungen/Stunde
h - Stunden
A, B, C - Betriebstyp (gleichmäßig, variabel, mit Stöße)
n - Anzahl

Fattore di accelerazione - Acceleration factor - Beschleunigungsfaktor

Il Fattore di accelerazione delle masse [$k_{(a)} \leq 0.2$] è inteso come rappresentativo di un funzionamento di 8 ore al giorno per Classe di carico A.

Per altre condizioni di lavoro, selezionare $k_{(a)}$ secondo i grafici alle pagine 3 e 4 del Catalogo FS - Fattori di servizio..

The Mass Acceleration factor [$k_{(a)} \leq 0.2$] is used to represent an operation of 8 hours per day for Load class A.

For other working conditions, select $k_{(a)}$ according to the charts on pages 3 and 4 of the Catalogue FS - Service factors.

Der Massenbeschleunigungs Faktor [$k_{(a)} \leq 0.2$] gilt als repräsentativ für einen Betrieb von 8 Stunden pro Tag je Belastungsklasse A.

Für andere Arbeitsbedingungen wählen Sie $k_{(a)}$ nach den Grafiken auf Seite 3 und 4 des FS-Katalog - Betriebsfaktoren.

$$k_a = \frac{J_2 + J_1}{i_r^2 + J_m}$$

$k_{(a)}$	
A	$k_{(a)} \leq 0.2$
B	$0.2 < k_{(a)} \leq 3$
C	$3 < k_{(a)} \leq 10$

k_a - fattore di accelerazione
A, B, C - classe di carico (uniforme, urti moderati, urti forti)
 J_1, J_2 - momento d'inerzia del riduttore (entrata, uscita)
 J_m - momento d'inerzia del motore
 i_r - rapporto di riduzione reale

k_a - acceleration factor
A, B, C - load class
 J_1, J_2 - moment of inertia of the gearbox (input, output)
 J_m - moment of inertia of the motor
 i_r - real reduction ratio

k_a - Beschleunigungsfaktor
A, B, C - Belastungsklassen (gleichmäßige, mit moderaten Stößen, mit starken Stößen)
 J_1, J_2 - Trägheitsmoment des Getriebes (Eingang, Ausgang)
 J_m - Trägheitsmoment des Motors
 i_r - Reales Übersetzungsverhältnis

Tipo di servizio Duty type Betriebsarten

Le specifiche dei tipi di servizi sono definiti dalle norme CEI EN 60034-1 / IEC34-1.

Duty types are defined by CEI EN 60034-1/ IEC34-1 Standard.

Die Betriebsarten sind definiert in den Normen CEI EN 60034-1 / IEC34-1.

S1 - Servizio continuo - Continuous duty - Dauerbetrieb

Funzionamento

- carico costante (c)
- periodo di tempo indefinito (N)
- periodo sufficiente a raggiungere l'equilibrio termico (t)

In servizio continuo, selezionare il riduttore con fattore di servizio SF1.0 o maggiore.

Operation

- steady load (c)
- indefinite period of time (N)
- period long enough to achieve thermal balancing (t)

On continuous duty, select the gearbox with service factor SF1.0 or higher

Betrieb

- konstanter Belastung (c)
- unbestimmte Zeit (N)
- genügend Zeit bis zum Erreichen des Temperaturgleichgewichts (t)

Bei Dauerbetrieb wählen Sie das Getriebe mit dem Betriebsfaktor SF1.0 oder höher.

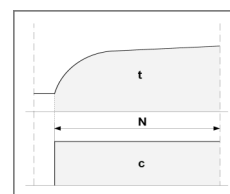

S3 - Servizio intermittente periodico - Periodic intermittent duty - Periodischer Aussetzbetriebe

Funzionamento

- carico costante (c)
- secondo un ciclo (C)
- con un periodo di tempo a carico costante (N)
- e un tempo di riposo (R).

Gli avviamenti non influiscono sulle temperature (t).

Il ciclo di riferimento (C) è di 10 minuti complessivi.

In servizio intermittente periodico, selezionare il riduttore con l'adeguato moltiplicatore k_{S3} o maggiore.

Il rapporto di intermittenza viene determinato secondo la formula seguente.

$$\frac{N}{(N+R)} * 100 = \begin{cases} \geq 10\% & k_{S3} 0.9 \\ 10\% & k_{S3} 0.85 \\ \geq 25\% & k_{S3} 0.75 \\ 15\% & k_{S3} 0.7 \end{cases}$$

c - carico
C - ciclo di lavoro
N - tempo di lavoro
R - tempo di riposo
t - temperatura

Operation

- steady load (c)
- according to a cycle (C)
- including a steady load time (N)
- and a rest time (R)

Starts/stops do not affect temperature (t).

Reference cycle (C) is 10 minutes overall.

On periodic intermittent duty, select the gearbox with the appropriate multiplier k_{S3} or higher.

Intermittence ratio is calculated according the following formula.

c - load
C - duty cycle
N - operation time
R - rest time
t - temperature

Betrieb

- konstanter Belastung (c)
- nach einem Zyklus (C)
- mit einer konstanten Zulaufzeit (N)
- und einer Ruhelage (R)

Die Schaltungen haben keine Wirkung auf die Temperaturen (t). Die Zyklusdauer (C) gilt eine Zeit von 10 Minuten.

Bei periodischem Aussetzbetrieb, wählen Sie das Getriebe mit dem entsprechenden Multiplikator k_{S3} oder höher.

Die Intermittenzübersetzung wird nach die folgende Formel bestimmt.

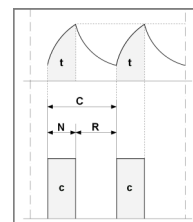

Carichi esterni
External loads
Ausgangsbelastungen

Carico radiale - Radial (overhung) load - Radialbelastung

Il carico radiale deve essere verificato in base

- alla velocità di uscita,
- al punto di applicazione
- all'elemento di trasmissione montato sull'albero di uscita del riduttore
- e quindi rettificato tramite i relativi fattori k_L e k_T .

Il carico radiale del riduttore F_{r2} deve essere uguale o maggiore al carico radiale dell'applicazione F_r .

- Punto di applicazione - Application point - Anwendung Punkt
 Il carico radiale è considerato applicato alla mezzzeria dell'albero di uscita. Altre posizioni originano carichi da correggere con l'appropriato fattore k_L .

The radial (OHL) load of the Catalogue should be checked according to

- output speed,
- mounting position,
- the transmission element fitted on the output shaft of the gearbox,
- and then rectified by the appropriate k_L and k_T rating factors.

Gearbox radial load F_{r2} must be greater than or equal to application radial load F_r .

- The radial load is considered as applied at the output shaft midpoint. Other positions origin loads to be adjusted by the appropriate factor k_L .

Die radiale Belastung in den Tabellen müssen mit entsprechende

- der Abtriebsdrehzahl,
- der Montageposition
- dem Übertragungselement montiert auf der Ausgangswelle des Getriebes
- und durch entsprechendem Faktoren k_L und k_T verglichen werden.

Die Radialbelastung des Getriebes F_{r2} muss gleich oder größer als die Radialbelastung der Anwendung F_r sein.

- Die Radialbelastung wird auf der Mitte der Ausgangswelle angelegt. Andere Positionen erzeugen Lasten, die mit dem entsprechendem Faktor k_L zu korrigieren sind.

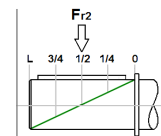

k_L	L [mm]
1.1	1/4 * L
1.0	1/2 * L
0.9	3/4 * L
0.8	L

- Elemento della trasmissione - Transmission element - Übertragungselement

k_T	Tipo dell'elemento	Element type	Elementtyp
1,15	Ingranaggio n. denti < 17	Gear tooth No. < 17	Zahnrad Zähnezahl < 17
1,40	Pignone catena n. denti < 13	Chain sprocket tooth No. < 13	Kettenrad Zähnezahl < 13
1,25	n. denti < 20	tooth No. < 20	Zähnezahl < 20
1,00	n. denti > 20	tooth No. > 20	Zähnezahl > 20
1,75	Puleggia per cinghie trapezoidali	Pulley for V-belt	Riemen für Keilriemen
2,50	cinghie piane	flat belts	Flachriemen
2,25	cinghie dentate	toothed-belt	Zahnriemen

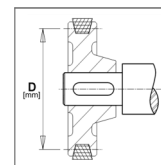

Carico assiale - Axial load - Axialbelastung

Il carico assiale è incluso nel carico radiale di catalogo come il 20% del valore F_{r2} ed è valido per carichi assiali sia a trazione che a compressione.

The axial load is included in the catalogue radial load as 20% of F_{r2} value and it is valid for both tensile and compressive axial stress.

Die axiale Belastung ist als 20% des Wertes F_{r2} in der radialen Katalogbelastung enthalten und gilt sowohl für Zug- als auch für Druckbelastungen.

Carico radiale - Radial load - Radialbelastung	Carico assiale - Axial load - Axialbelastung
$F_{r2} = (2000 \times M_2) : D \times k_L \times k_T$ $F_{r2} \geq F_r$	$F_{a2} = F_{r2} \times 0.2$

F_{a2} - carico assiale ammesso

F_r - carico radiale dell'applicazione

F_{r2} - carico radiale del riduttore

D - diametro elemento della trasmissione

k_L - fattore punto di applicazione

k_T - fattore elemento della trasmissione

M_2 - coppia di uscita del riduttore

F_{a2} - permissible axial load

F_r - radial load of application

F_{r2} - radial load of gearbox

D - transmission element diameter

k_L - application point factor

k_T - transmission element factor

M_2 - output torque of gearbox

F_{a2} - Zulässige axiale Belastung

F_r - Radial Belastung der Anwendung

F_{r2} - Radial Belastung des Getriebes

D - Durchmesser des Übertragungselementes

k_L - Anwendung Punkt Faktor

k_T - Übertragungselement Faktor

M_2 - Ausgangsdrehmoment des Getriebes

Versioni Versions Ausführungen

MRO-2

Motoriduttori

- albero cavo uscita
- due coppie di ingranaggi
- fissaggio a piedi, flangia uscita e pendolare

Geared motors

- output hollow shaft
- two gear sets
- foot-, flange- and shaft-mounting

Getriebemotoren

- Ausgangshohlwelle
- Zweistufig
- Fuß-, Flansch- u. Aufsteckausführung

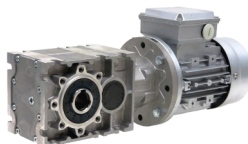

FRO-2

Riduttori con flangia motore di entrata

- albero cavo uscita e giunto in entrata
- due coppie di ingranaggi
- fissaggio a piedi, flangia uscita e pendolare

Gearboxes with input motor flange

- hollow output shaft and input coupling
- two gear sets
- foot-, flange- and shaft-mounting

Getriebe mit Motorflansch

- Ausgangshohlwelle und Eingangskupplung
- Zweistufig
- Fuß-, Flansch- u. Aufsteckausführung



SRO-2

Riduttori senza flangia motore di entrata

- albero cavo uscita e giunto in entrata
- due coppie di ingranaggi
- fissaggio a piedi, flangia uscita e pendolare

Gearboxes without input motor flange

- hollow output shaft and input coupling
- two gear sets
- foot-, flange- and shaft-mounting

Getriebe ohne Motorflansch

- Ausgangshohlwelle und Eingangskupplung
- Zweistufig
- Fuß-, Flansch- u. Aufsteckausführung



RO-2

Riduttori con albero entrata sporgente

- albero cavo uscita
- due coppie di ingranaggi
- fissaggio a piedi, flangia uscita e pendolare

Gearboxes with input solid shaft

- hollow output shaft
- two gear sets
- foot-, flange- and shaft-mounting

Getriebe mit Eingang-Freiewelle

- Ausgangshohlwelle
- Zweistufig
- Fuß-, Flansch- u. Aufsteckausführung



Potenza termica
Thermal power
Thermische Leistung

i_n	RO02			RO12			RO22			RO32		
	i_r	P_1 [kW]	P_{t1} [kW]	i_r	P_1 [kW]	P_{t1} [kW]	i_r	P_1 [kW]	P_{t1} [kW]	i_r	P_1 [kW]	P_{t1} [kW]
5	5,18	3,2	5,9	5,03	4,2	8,2	5,18	5,4	12	5,18	8,1	15
7,1	7,19	2,4	4,8	7,09	3,8	6,5	7,28	5,5	9,2	7,28	6,0	13
8	8,58	2,0	4,5	8,74	3,2	6,9	8,36	4,8	9,6	8,54	5,5	13
10	10,88	1,7	4,2	10,57	2,9	5,9	10,88	3,9	8,3	10,88	5,3	11
11,2	-	-	-	12,34	1,9	5,1	11,71	3,6	7,3	11,6	5,4	8,4
14	15,1	1,1	3,7	14,9	2,1	5,0	15,31	3,4	7,0	15,31	4,9	10
16	16,36	1,0	3,4	15,91	1,7	4,9	16,36	3,1	6,9	16,36	4,6	9,5
18	18,03	1,0	3,4	18,37	1,7	5,3	17,56	2,9	7,4	17,95	4,3	10
20	21,75	0,8	3,1	21,75	1,2	4,7	22,35	2,3	6,7	21,35	3,6	9,1
22,4	22,73	0,8	3,1	22,42	1,4	4,3	23,03	2,2	5,7	23,03	3,4	8,6
25	24,41	0,6	2,8	25,92	0,9	4,2	24,61	1,9	6,0	24,39	3,2	7,2
28	27,13	0,6	2,9	27,64	1,1	4,4	26,42	1,9	6,2	27,01	2,9	8,7
31,5	31,88	0,5	2,6	31,45	1,0	3,7	32,3	1,6	5,0	32,3	2,4	7,2
31,5	32,73	0,5	2,7	32,73	0,8	4,0	33,64	1,5	5,7	-	-	6,4
35,5	36,73	0,4	2,5	38,76	0,8	3,8	37,06	1,4	5,2	36,69	2,1	7,3
35,5	38,05	0,5	2,5	-	-	-	-	-	-	37,89	2,1	6,6
45	45,9	0,3	2,3	45,9	0,6	3,5	47,18	1,1	4,8	45,05	1,7	5,5
50	51,51	0,3	2,2	54,71	0,4	3,2	51,93	1,0	4,5	51,46	1,5	

La potenza nominale è la potenza che può essere applicata all'entrata del riduttore, in servizio continuo, temperatura max. ambiente di 40 °C, altitudine max. 1000 m, senza superare una temperatura dell'olio di circa 85 °C.

La potenza termica può limitare la potenza nominale in funzione del sistema di raffreddamento, della velocità di entrata, della temperatura ambiente e del coefficiente di servizio.

The rated power is the power that can be applied to the input of the gearbox, on continuous service, max. room temperature of 40 °C, max. altitude 1000 m, without exceeding an oil temperature of about 85 °C.

The thermal power can limit the rated power depending on the cooling system, the input speed, the ambient temperature and the service factor.

Die Nennleistung ist die Leistung, die am Getriebe angewendet werden kann, Dauerbetriebstemperatur von 40 °C, max. Höhe 1000 m ohne, mehr als eine Temperatur von Öl von etwa 85 °C.

Die thermische Leistung kann der Nennleistung P_1 als Funktion des Kühlsystems der Antriebsdrehzahl, Umgebungstemperatur und der Koeffizient der Service begrenzen.

i_n - rapporto di riduzione nominale
 i_r - rapporto reale
 P_1 - potenza nominale
 P_{t1} - potenza termica

i_n - nominal reduction ratio
 i_r - actual reduction ratio
 P_1 - nominal power
 P_{t1} - thermal power

i_n - nominal Untersetzungsverhältnis
 i_r - tatsächlich Untersetzungsverhältnis
 P_1 - Nennleistung
 P_{t1} - thermische Leistung.

FRO/RO 02 - 120 Nm
FRO/RO 12 - 200 Nm

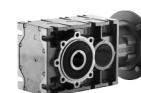
 Riduttore
 Gearbox
 Getriebe

1400 rpm	i_n	i_r	n_2 [rpm]	M_2 [Nm]	P_1 [kW]	F_{r1} [N]	F_{r2} [N]	$J_1 \times 10^{-4}$ [kgm ²]	56 B5	63 B*	71 B*	80 B*	90 B*
FRO 02 RO 02	5	5.180	271	105	3.2	1200	1700	1.21	⊙	⊙	⊙	⊙	⊙
	7,1	7.190	195	110	2.4	1250	2000	1.01	⊙	⊙	⊙	⊙	⊙
	8	8.580	163	110	2.0	1250	2200	0.94	⊙	⊙	⊙	⊙	⊙
	10	10.880	129	120	1.7	1250	2300	0.64	⊙	⊙	⊙	⊙	⊙
	14	15.100	93	110	1.1	1280	2850	0.59	⊙	⊙	⊙	⊙	⊙
	16	16.360	86	100	1.0	1280	3000	0.55	⊙	⊙	⊙	⊙	⊙
	18	18.030	78	110	1.0	1300	3100	0.58	⊙	⊙	⊙	⊙	⊙
	20	21.750	64	110	0.8	1300	3400	0.56	⊙	⊙	⊙	⊙	
	22,4	22.730	62	110	0.8	1300	3400	0.53	⊙	⊙	⊙	⊙	
	25	24.410	57	100	0.6	1300	3700	0.56	⊙	⊙	⊙	⊙	
	28	27.130	52	110	0.6	1300	3700	0.52	⊙	⊙	⊙	⊙	
	31,5	31.880	44	100	0.5	1300	3950	0.50	⊙	⊙	⊙	⊙	
	31,5	32.730	43	100	0.5	1300	4150	0.51	⊙	⊙	⊙	⊙	
	35,5	36.730	38	100	0.4	1300	4350	0.51	⊙	⊙	⊙	⊙	
	35,5	38.050	37	100	0.4	1300	4200	0.49	⊙	⊙	⊙		
	45	45.900	31	100	0.3	1300	4900	0.49	⊙	⊙	⊙		
50	51.510	27	100	0.3	1300	4900	0.49	⊙	⊙	⊙			

1400 rpm	i_n	i_r	n_2 [rpm]	M_2 [Nm]	P_1 [kW]	F_{r1} [N]	F_{r2} [N]	$J_1 \times 10^{-4}$ [kgm ²]	63 B5	71 B*	80 B*	90 B*	100 B*	112 B*
FRO 12 RO 12	5	5.030	278	135	4.2	1500	2300	3.20	⊙	⊙	⊙	⊙	⊙	⊙
	7,1	7.090	197	175	3.8	1550	2450	2.70	⊙	⊙	⊙	⊙	⊙	⊙
	8	8.740	160	180	3.2	1580	2700	2.50	⊙	⊙	⊙	⊙	⊙	⊙
	10	10.570	132	200	2.9	1580	2700	2.03	⊙	⊙	⊙	⊙	⊙	
	11,2	12.340	114	150	1.9	1600	3550	2.27	⊙	⊙	⊙	⊙	⊙	
	14	14.900	94	200	2.1	1600	3350	1.92	⊙	⊙	⊙	⊙	⊙	
	16	15.910	88	170	1.7	1610	3650	1.84	⊙	⊙	⊙	⊙	⊙	
	18	18.370	76	200	1.7	1610	3750	1.87	⊙	⊙	⊙	⊙	⊙	
	20	21.750	64	170	1.2	1610	4350	1.85	⊙	⊙	⊙	⊙		
	22,4	22.420	62	200	1.4	1610	4100	1.79	⊙	⊙	⊙	⊙		
	25	25.920	54	150	0.9	1610	4850	1.82	⊙	⊙	⊙	⊙		
	28	27.640	51	200	1.1	1610	4550	1.77	⊙	⊙	⊙	⊙		
	31,5	31.450	45	200	1.0	1610	4800	1.74	⊙	⊙	⊙	⊙		
	31,5	32.730	43	170	0.8	1610	5200	1.76	⊙	⊙	⊙			
	35,5	38.760	36	200	0.8	1610	5300	1.73	⊙	⊙	⊙			
	45	45.900	31	170	0.6	1610	5700	1.73	⊙	⊙	⊙			
50	54.710	26	150	0.4	1610	5750	1.72	⊙	⊙	⊙				

B* - B5 & B14

FRO/RO 22 - 330 Nm
FRO/RO 32 - 500 Nm
 Riduttore
 Gearbox
 Getriebe

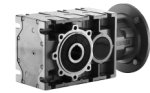

1400 rpm	i_n	i_r	n_2 [rpm]	M_2 [Nm]	P_1 [kW]	F_{r1} [N]	F_{r2} [N]	$J_1 \times 10^{-4}$ [kgm ²]	63 B5	71 B5	80 B*	90 B*	100 B*	112 B*
FRO 22 RO 22	5	5.180	271	180	5.4	2900	3150	5.89	⊙	⊙	⊙	⊙	⊙	⊙
	7,1	7.280	192	255	5.5	2900	3200	4.79	⊙	⊙	⊙	⊙	⊙	⊙
	8	8.360	168	260	4.8	2900	3450	4.50	⊙	⊙	⊙	⊙	⊙	⊙
	10	10.880	129	270	3.9	2900	3700	3.55	⊙	⊙	⊙	⊙	⊙	⊙
	11,2	11.710	120	270	3.6	3000	4050	3.95	⊙	⊙	⊙	⊙	⊙	⊙
	14	15.310	92	330	3.4	3000	4100	3.30	⊙	⊙	⊙	⊙	⊙	⊙
	16	16.360	86	330	3.1	3000	4100	3.16	⊙	⊙	⊙	⊙	⊙	⊙
	18	17.560	80	330	2.9	3000	4450	3.23	⊙	⊙	⊙	⊙	⊙	⊙
	20	22.350	63	330	2.3	3000	5000	3.14	⊙	⊙	⊙	⊙	⊙	⊙
	22,4	23.030	61	330	2.2	3000	5000	3.05	⊙	⊙	⊙	⊙	⊙	⊙
	25	24.610	57	300	1.9	3000	5500	3.11	⊙	⊙	⊙	⊙	⊙	⊙
	28	26.420	53	330	1.9	3000	5450	3.02	⊙	⊙	⊙	⊙	⊙	⊙
	31,5	32.300	43	330	1.6	3000	5900	2.96	⊙	⊙	⊙	⊙	⊙	⊙
	31,5	33.640	42	330	1.5	3000	6100	2.98	⊙	⊙	⊙	⊙	⊙	⊙
	35,5	37.060	38	330	1.4	3000	6350	2.94	⊙	⊙	⊙	⊙	⊙	⊙
	45	47.180	30	330	1.1	3000	6400	2.92	⊙	⊙	⊙	⊙	⊙	⊙
50	51.930	27	300	1.0	3000	6450	2.91	⊙	⊙	⊙	⊙	⊙	⊙	

1400 rpm	i_n	i_r	n_2 [rpm]	M_2 [Nm]	P_1 [kW]	F_{r1} [N]	F_{r2} [N]	$J_1 \times 10^{-4}$ [kgm ²]	71 B5	80 B5	90 B5	100 B*	112 B*	132 B*
FRO 32 RO 32	5	5.180	271	270	8.1	4500	4800	9.07	⊙	⊙	⊙	⊙	⊙	⊙
	7,1	7.280	192	280	6.0	4550	5650	6.77	⊙	⊙	⊙	⊙	⊙	⊙
	8	8.540	164	300	5.5	5540	6000	6.07	⊙	⊙	⊙	⊙	⊙	⊙
	10	10.880	129	370	5.3	5630	6000	4.27	⊙	⊙	⊙	⊙	⊙	⊙
	11,2	11.600	121	400	5.4	5710	6400	4.99	⊙	⊙	⊙	⊙	⊙	⊙
	14	15.310	92	480	4.9	5710	6450	3.75	⊙	⊙	⊙	⊙	⊙	⊙
	16	16.360	86	480	4.6	5730	6500	3.48	⊙	⊙	⊙	⊙	⊙	⊙
	18	17.950	78	500	4.3	5730	6900	3.59	⊙	⊙	⊙	⊙	⊙	⊙
	20	21.350	66	500	3.6	5680	7550	3.43	⊙	⊙	⊙	⊙	⊙	⊙
	22,4	23.030	61	500	3.4	5730	7700	3.25	⊙	⊙	⊙	⊙	⊙	⊙
	25	24.390	57	500	3.2	5740	8300	3.34	⊙	⊙	⊙	⊙	⊙	⊙
	28	27.010	52	500	2.9	5730	8400	3.18	⊙	⊙	⊙	⊙	⊙	⊙
	31,5	32.300	43	500	2.4	5740	9050	3.06	⊙	⊙	⊙	⊙	⊙	⊙
	35,5	36.690	38	500	2.1	5740	9950	3.07	⊙	⊙	⊙	⊙	⊙	⊙
	35,5	37.890	37	500	2.1	5740	9800	3.02	⊙	⊙	⊙	⊙	⊙	⊙
	45	45.050	31	500	1.7	5740	9800	2.99	⊙	⊙	⊙	⊙	⊙	⊙
50	51.460	27	500	1.5	5740	9800	2.97	⊙	⊙	⊙	⊙	⊙	⊙	

B* - B5 & B14
 ⊙ - foro con cava chiavetta

B* - B5 & B14
 ⊙ - bore with keyway

B* - B5 & B14
 ⊙ - Bohrung mit Keilriemen

MRO-2 - 1400 rpm
 Motoriduttore
 Geared motor
 Getriebemotor

P ₁ [kW]	n ₂ [rpm]	Tipo - Size - Größe	i _r	M ₂ [Nm]	FS	MRO [kg]	FRO [kg]	F _{r2} [N]	J _m × 10 ⁻⁴	J ₁ × 10 ⁻⁴
0,06	270	MRO 02 - 56A4	5,18	2	>3	7,3	4,4	1700	1,5	1,214
	195	MRO 02 - 56A4	7,19	2,8	>3	7,3	4,4	2000	1,5	1,015
	163	MRO 02 - 56A4	8,58	3,4	>3	7,3	4,4	2200	1,5	0,944
	129	MRO 02 - 56A4	10,88	4,3	>3	7,3	4,4	2300	1,5	0,639
	93	MRO 02 - 56A4	15,1	5,9	>3	7,3	4,4	2850	1,5	0,593
	86	MRO 02 - 56A4	16,36	6,4	>3	7,3	4,4	3000	1,5	0,545
	78	MRO 02 - 56A4	18,03	7,1	>3	7,3	4,4	3100	1,5	0,578
	64	MRO 02 - 56A4	21,75	8,5	>3	7,3	4,4	3400	1,5	0,564
	62	MRO 02 - 56A4	22,73	8,9	>3	7,3	4,4	3400	1,5	0,525
	57	MRO 02 - 56A4	24,41	9,6	>3	7,3	4,4	3700	1,5	0,557
	52	MRO 02 - 56A4	27,13	11	>3	7,3	4,4	3700	1,5	0,518
	44	MRO 02 - 56A4	31,88	13	>3	7,3	4,4	3950	1,5	0,498
	43	MRO 02 - 56A4	32,73	13	>3	7,3	4,4	4150	1,5	0,512
	38	MRO 02 - 56A4	36,73	14	>3	7,3	4,4	4350	1,5	0,509
	37	MRO 02 - 56A4	38,05	15	>3	7,3	4,4	4200	1,5	0,494
	31	MRO 02 - 56A4	45,9	18	>3	7,3	4,4	4900	1,5	0,491
	27	MRO 02 - 56A4	51,51	20	>3	7,3	4,4	4900	1,5	0,49
0,09	270	MRO 02 - 56B4	5,18	3,1	>3	7,6	4,4	1700	2	1,214
	195	MRO 02 - 56B4	7,19	4,2	>3	7,6	4,4	2000	2	1,015
	163	MRO 02 - 56B4	8,58	5,1	>3	7,6	4,4	2200	2	0,944
	129	MRO 02 - 56B4	10,88	6,4	>3	7,6	4,4	2300	2	0,639
	93	MRO 02 - 56B4	15,1	8,9	>3	7,6	4,4	2850	2	0,593
	86	MRO 02 - 56B4	16,36	9,6	>3	7,6	4,4	3000	2	0,545
	78	MRO 02 - 56B4	18,03	11	>3	7,6	4,4	3100	2	0,578
	64	MRO 02 - 56B4	21,75	13	>3	7,6	4,4	3400	2	0,564
	62	MRO 02 - 56B4	22,73	13	>3	7,6	4,4	3400	2	0,525
	57	MRO 02 - 56B4	24,41	14	>3	7,6	4,4	3700	2	0,557
	52	MRO 02 - 56B4	27,13	16	>3	7,6	4,4	3700	2	0,518
	44	MRO 02 - 56B4	31,88	19	>3	7,6	4,4	3950	2	0,498
	43	MRO 02 - 56B4	32,73	19	>3	7,6	4,4	4150	2	0,512
	38	MRO 02 - 56B4	36,73	22	>3	7,6	4,4	4350	2	0,509
	37	MRO 02 - 56B4	38,05	22	>3	7,6	4,4	4200	2	0,494
	31	MRO 02 - 56B4	45,9	27	>3	7,6	4,4	4900	2	0,491
	27	MRO 02 - 56B4	51,51	30	>3	7,6	4,4	4900	2	0,49
0,12	278	MRO 12 - 63A4	5,03	4	>3	10,7	7	2300	2,8	3,2008
	270	MRO 22 - 63A4	5,18	4,1	>3	14,7	11	3150	2,8	5,8944
		MRO 02 - 63A4	5,18	4,1	>3	8,1	4,4	1700	2,8	1,214
	197	MRO 12 - 63A4	7,09	5,6	>3	10,7	7	2450	2,8	2,6978
	195	MRO 02 - 63A4	7,19	5,7	>3	8,1	4,4	2000	2,8	1,015
	192	MRO 22 - 63A4	7,28	5,7	>3	14,7	11	3200	2,8	4,792
	167	MRO 22 - 63A4	8,36	6,6	>3	14,7	11	3450	2,8	4,5033
	163	MRO 02 - 63A4	8,58	6,7	>3	8,1	4,4	2200	2,8	0,944
	160	MRO 12 - 63A4	8,74	6,9	>3	10,7	7	2700	2,8	2,5046
	132	MRO 12 - 63A4	10,57	8,3	>3	10,7	7	2700	2,8	2,0326
	129	MRO 22 - 63A4	10,88	8,6	>3	14,7	11	3700	2,8	3,5463
		MRO 02 - 63A4	10,88	8,6	>3	8,1	4,4	2300	2,8	0,639
	120	MRO 22 - 63A4	11,71	9,2	>3	14,7	11	4050	2,8	3,9507
	113	MRO 12 - 63A4	12,34	9,7	>3	10,7	7	3550	2,8	2,2731
	94	MRO 12 - 63A4	14,9	12	>3	10,7	7	3350	2,8	1,9187
	93	MRO 02 - 63A4	15,1	12	>3	8,1	4,4	2850	2,8	0,593



MRO-2 - 1400 rpm
 Motoriduttore
 Geared motor
 Getriebemotor

P ₁ [kW]	n ₂ [rpm]	Tipo - Size - Größe	i _r	M ₂ [Nm]	FS	MRO [kg]	FRO [kg]	F _{r2} [N]	J _m × 10 ⁻⁴	J ₁ × 10 ⁻⁴
0,12	91	MRO 22 - 63A4	15,31	12	>3	14,7	11	4100	2,8	3,2966
	88	MRO 12 - 63A4	15,91	13	>3	10,7	7	3650	2,8	1,8416
	86	MRO 22 - 63A4	16,36	13	>3	14,7	11	4100	2,8	3,1625
		MRO 02 - 63A4	16,36	13	>3	8,1	4,4	3000	2,8	0,545
	80	MRO 22 - 63A4	17,56	14	>3	14,7	11	4450	2,8	3,2313
	78	MRO 02 - 63A4	18,03	14	>3	8,1	4,4	3100	2,8	0,578
	76	MRO 12 - 63A4	18,37	14	>3	10,7	7	3750	2,8	1,8749
	64	MRO 12 - 63A4	21,75	17	>3	10,7	7	4350	2,8	1,8457
		MRO 02 - 63A4	21,75	17	>3	8,1	4,4	3400	2,8	0,564
	63	MRO 22 - 63A4	22,35	18	>3	14,7	11	5000	2,8	3,1366
	62	MRO 12 - 63A4	22,42	18	>3	10,7	7	4100	2,8	1,7913
		MRO 02 - 63A4	22,73	18	>3	8,1	4,4	3400	2,8	0,525
	61	MRO 22 - 63A4	23,03	18	>3	14,7	11	5000	2,8	3,0523
	57	MRO 22 - 63A4	24,61	19	>3	14,7	11	5500	2,8	3,1062
		MRO 02 - 63A4	24,41	19	>3	8,1	4,4	3700	2,8	0,557
	54	MRO 12 - 63A4	25,92	20	>3	10,7	7	4850	2,8	1,8225
	53	MRO 22 - 63A4	26,42	21	>3	14,7	11	5450	2,8	3,0234
	52	MRO 02 - 63A4	27,13	21	>3	8,1	4,4	3700	2,8	0,518
	51	MRO 12 - 63A4	27,64	22	>3	10,7	7	4550	2,8	1,772
	45	MRO 12 - 63A4	31,45	25	>3	10,7	7	4800	2,8	1,7418
	44	MRO 02 - 63A4	31,88	25	>3	8,1	4,4	3950	2,8	0,498
	43	MRO 22 - 63A4	32,3	25	>3	14,7	11	5900	2,8	2,9572
		MRO 12 - 63A4	32,73	26	>3	10,7	7	5200	2,8	1,7591
		MRO 02 - 63A4	32,73	26	>3	8,1	4,4	4150	2,8	0,512
	42	MRO 22 - 63A4	33,64	26	>3	14,7	11	6100	2,8	2,9816
	38	MRO 22 - 63A4	37,06	29	>3	14,7	11	6350	2,8	2,9425
		MRO 02 - 63A4	36,73	29	>3	8,1	4,4	4350	2,8	0,509
	37	MRO 12 - 63A4	38,05	30	>3	8,1	4,4	4200	2,8	0,494
	36	MRO 12 - 63A4	38,76	30	>3	10,7	7	5300	2,8	1,732
	31	MRO 12 - 63A4	45,9	36	>3	10,7	7	5700	2,8	1,7254
MRO 02 - 63A4		45,9	36	2,8	8,1	4,4	4900	2,8	0,491	
30	MRO 22 - 63A4	47,18	37	>3	14,7	11	6400	2,8	2,9213	
27	MRO 22 - 63A4	51,93	41	>3	14,7	11	6450	2,8	2,9144	
	MRO 02 - 63A4	51,51	40	2,5	8,1	4,4	4900	2,8	0,49	
26	MRO 12 - 63A4	54,71	43	>3	10,7	7	5750	2,8	1,7202	
0,18	278	MRO 12 - 63B4	5,03	5,9	>3	11,2	7	2300	4	3,2008
	270	MRO 22 - 63B4	5,18	6,1	>3	15,2	11	3150	4	5,8944
		MRO 02 - 63B4	5,18	6,1	>3	8,6	4,4	1700	4	1,214
	197	MRO 12 - 63B4	7,09	8,4	>3	11,2	7	2450	4	2,6978
	195	MRO 02 - 63B4	7,19	8,5	>3	8,6	4,4	2000	4	1,015
	192	MRO 22 - 63B4	7,28	8,6	>3	15,2	11	3200	4	4,792
	167	MRO 22 - 63B4	8,36	9,9	>3	15,2	11	3450	4	4,5033
	163	MRO 02 - 63B4	8,58	10	>3	8,6	4,4	2200	4	0,944
	160	MRO 12 - 63B4	8,74	10	>3	11,2	7	2700	4	2,5046
	132	MRO 12 - 63B4	10,57	12	>3	11,2	7	2700	4	2,0326
	129	MRO 22 - 63B4	10,88	13	>3	15,2	11	3700	4	3,5463
		MRO 02 - 63B4	10,88	13	>3	8,6	4,4	2300	4	0,639
	120	MRO 22 - 63B4	11,71	14	>3	15,2	11	4050	4	3,9507
	113	MRO 12 - 63B4	12,34	15	>3	11,2	7	3550	4	2,2731
	94	MRO 12 - 63B4	14,9	18	>3	11,2	7	3350	4	1,9187



MRO-2 - 1400 rpm
 Motoriduttore
 Geared motor
 Getriebemotor

P ₁ [kW]	n ₂ [rpm]	Tipo - Size - Größe	i _r	M ₂ [Nm]	FS	MRO [kg]	FRO [kg]	F _{r2} [N]	J _m × 10 ⁻⁴	J ₁ × 10 ⁻⁴	
0,18	93	MRO 02 - 63B4	15,1	18	>3	8,6	4,4	2850	4	0,593	
	91	MRO 22 - 63B4	15,31	18	>3	15,2	11	4100	4	3,2966	
	88	MRO 12 - 63B4	15,91	19	>3	11,2	7	3650	4	1,8416	
	86	MRO 22 - 63B4	16,36	19	>3	15,2	11	4100	4	3,1625	
			MRO 02 - 63B4	16,36	19	>3	8,6	4,4	3000	4	0,545
	80	MRO 22 - 63B4	17,56	21	>3	15,2	11	4450	4	3,2313	
	78	MRO 02 - 63B4	18,03	21	>3	8,6	4,4	3100	4	0,578	
	76	MRO 12 - 63B4	18,37	22	>3	11,2	7	3750	4	1,8749	
	64	MRO 12 - 63B4	21,75	26	>3	11,2	7	4350	4	1,8457	
			MRO 02 - 63B4	21,75	26	>3	8,6	4,4	3400	4	0,564
	63	MRO 22 - 63B4	22,35	26	>3	15,2	11	5000	4	3,1366	
	62	MRO 12 - 63B4	22,42	26	>3	11,2	7	4100	4	1,7913	
			MRO 02 - 63B4	22,73	27	>3	8,6	4,4	3400	4	0,525
	61	MRO 22 - 63B4	23,03	27	>3	15,2	11	5000	4	3,0523	
	57	MRO 22 - 63B4	24,61	29	>3	15,2	11	5500	4	3,1062	
			MRO 02 - 63B4	24,41	29	>3	8,6	4,4	3700	4	0,557
	54	MRO 12 - 63B4	25,92	31	>3	11,2	7	4850	4	1,8225	
	53	MRO 22 - 63B4	26,42	31	>3	15,2	11	5450	4	3,0234	
	52	MRO 02 - 63B4	27,13	32	>3	8,6	4,4	3700	4	0,518	
	51	MRO 12 - 63B4	27,64	33	>3	11,2	7	4550	4	1,772	
	45	MRO 12 - 63B4	31,45	37	>3	11,2	7	4800	4	1,7418	
	44	MRO 02 - 63B4	31,88	38	2,7	8,6	4,4	3950	4	0,498	
	43	MRO 22 - 63B4	32,3	38	>3	15,2	11	5900	4	2,9572	
			MRO 12 - 63B4	32,73	39	>3	11,2	7	5200	4	1,7591
			MRO 02 - 63B4	32,73	39	2,6	8,6	4,4	4150	4	0,512
	42	MRO 22 - 63B4	33,64	40	>3	15,2	11	6100	4	2,9816	
	38	MRO 22 - 63B4	37,06	44	>3	15,2	11	6350	4	2,9425	
			MRO 02 - 63B4	36,73	43	2,3	8,6	4,4	4350	4	0,509
	37	MRO 02 - 63B4	38,05	45	2,2	8,6	4,4	4200	4	0,494	
	36	MRO 12 - 63B4	38,76	46	>3	11,2	7	5300	4	1,732	
31	MRO 12 - 63B4	45,9	54	>3	11,2	7	5700	4	1,7254		
		MRO 02 - 63B4	45,9	54	1,8	8,6	4,4	4900	4	0,491	
30	MRO 22 - 63B4	47,18	56	>3	15,2	11	6400	4	2,9213		
27	MRO 22 - 63B4	51,93	61	>3	15,2	11	6450	4	2,9144		
		MRO 02 - 63B4	51,51	61	1,6	8,6	4,4	4900	4	0,49	
26	MRO 12 - 63B4	54,71	65	2,3	11,2	7	5750	4	1,7202		
0,25	278	MRO 12 - 63C4	5,03	8,2	>3	12	7	2300	4	3,2008	
		MRO 12 - 71A4	5,03	8,2	>3	12	7	2300	5	3,2008	
	270	MRO 32 - 71A4	5,18	8,5	>3	20	15	4800	5	9,0749	
		MRO 22 - 63C4	5,18	8,5	>3	16	11	3150	4	5,8944	
		MRO 22 - 71A4	5,18	8,5	>3	16	11	3150	5	5,8944	
		MRO 02 - 63C4	5,18	8,5	>3	9,4	4,4	1700	4	1,214	
		MRO 02 - 71A4	5,18	8,5	>3	9,4	4,4	1700	5	1,214	
	197	MRO 12 - 63C4	7,09	12	>3	12	7	2450	4	2,6978	
		MRO 12 - 71A4	7,09	12	>3	12	7	2450	5	2,6978	
	195	MRO 02 - 63C4	7,19	12	>3	9,4	4,4	2000	4	1,015	
		MRO 02 - 71A4	7,19	12	>3	9,4	4,4	2000	5	1,015	
	192	MRO 32 - 71A4	7,28	12	>3	20	15	5650	5	6,7749	
		MRO 22 - 63C4	7,28	12	>3	16	11	3200	4	4,792	
		MRO 22 - 71A4	7,28	12	>3	16	11	3200	5	4,792	



MRO-2 - 1400 rpm
 Motoriduttore
 Geared motor
 Getriebemotor

P ₁ [kW]	n ₂ [rpm]	Tipo - Size - Größe	i _r	M ₂ [Nm]	FS	MRO [kg]	FRO [kg]	F _{r2} [N]	J _m × 10 ⁻³	J ₁ × 10 ⁻⁴
0,25	167	MRO 22 - 63C4	8,36	14	>3	16	11	3450	4	4,5033
		MRO 22 - 71A4	8,36	14	>3	16	11	3450	5	4,5033
	164	MRO 32 - 71A4	8,54	14	>3	20	15	6000	5	6,07
163		MRO 02 - 63C4	8,58	14	>3	9,4	4,4	2200	4	0,944
		MRO 02 - 71A4	8,58	14	>3	9,4	4,4	2200	5	0,944
160		MRO 12 - 63C4	8,74	14	>3	12	7	2700	4	2,5046
		MRO 12 - 71A4	8,74	14	>3	12	7	2700	5	2,5046
132		MRO 12 - 63C4	10,57	17	>3	12	7	2700	4	2,0326
		MRO 12 - 71A4	10,57	17	>3	12	7	2700	5	2,0326
129		MRO 32 - 71A4	10,88	18	>3	20	15	6000	5	4,2665
		MRO 22 - 63C4	10,88	18	>3	16	11	3700	4	3,5463
		MRO 22 - 71A4	10,88	18	>3	16	11	3700	5	3,5463
		MRO 02 - 63C4	10,88	18	>3	9,4	4,4	2300	4	0,639
		MRO 02 - 71A4	10,88	18	>3	9,4	4,4	2300	5	0,639
121		MRO 32 - 71A4	11,6	19	>3	20	15	6400	5	4,9874
120		MRO 22 - 63C4	11,71	19	>3	16	11	4050	4	3,9507
		MRO 22 - 71A4	11,71	19	>3	16	11	4050	5	3,9507
113		MRO 12 - 63C4	12,34	20	>3	12	7	3550	4	2,2731
		MRO 12 - 71A4	12,34	20	>3	12	7	3550	5	2,2731
94		MRO 12 - 63C4	14,9	24	>3	12	7	3350	4	1,9187
		MRO 12 - 71A4	14,9	24	>3	12	7	3350	5	1,9187
93		MRO 02 - 63C4	15,1	25	>3	9,4	4,4	2850	4	0,593
		MRO 02 - 71A4	15,1	25	>3	9,4	4,4	2850	5	0,593
91		MRO 32 - 71A4	15,31	25	>3	20	15	6450	5	3,7457
		MRO 22 - 63C4	15,31	25	>3	16	11	4100	4	3,2966
		MRO 22 - 71A4	15,31	25	>3	16	11	4100	5	3,2966
88		MRO 12 - 63C4	15,91	26	>3	12	7	3650	4	1,8416
		MRO 12 - 71A4	15,91	26	>3	12	7	3650	5	1,8416
86		MRO 32 - 71A4	16,36	27	>3	20	15	6500	5	3,4806
		MRO 22 - 63C4	16,36	27	>3	16	11	4100	4	3,1625
		MRO 22 - 71A4	16,36	27	>3	16	11	4100	5	3,1625
		MRO 02 - 63C4	16,36	27	>3	9,4	4,4	3000	4	0,545
		MRO 02 - 71A4	16,36	27	>3	9,4	4,4	3000	5	0,545
80		MRO 22 - 63C4	17,56	29	>3	16	11	4450	4	3,2313
		MRO 22 - 71A4	17,56	29	>3	16	11	4450	5	3,2313
78		MRO 32 - 71A4	17,95	29	>3	20	15	6900	5	3,586
		MRO 02 - 63C4	18,03	30	>3	9,4	4,4	3100	4	0,578
		MRO 02 - 71A4	18,03	30	>3	9,4	4,4	3100	5	0,578
76		MRO 12 - 63C4	18,37	30	>3	12	7	3750	4	1,8749
		MRO 12 - 71A4	18,37	30	>3	12	7	3750	5	1,8749
66		MRO 32 - 71A4	21,35	35	>3	20	15	7550	5	3,4347
64		MRO 12 - 63C4	21,75	36	>3	12	7	4350	4	1,8457
		MRO 12 - 71A4	21,75	36	>3	12	7	4350	5	1,8457
		MRO 02 - 63C4	21,75	36	>3	9,4	4,4	3400	4	0,564
		MRO 02 - 71A4	21,75	36	>3	9,4	4,4	3400	5	0,564
63		MRO 22 - 63C4	22,35	37	>3	16	11	5000	4	3,1366
		MRO 22 - 71A4	22,35	37	>3	16	11	5000	5	3,1366
62		MRO 12 - 63C4	22,42	37	>3	12	7	4100	4	1,7913
		MRO 12 - 71A4	22,42	37	>3	12	7	4100	5	1,7913
		MRO 02 - 63C4	22,73	37	3	9,4	4,4	3400	4	0,525



MRO-2 - 1400 rpm
 Motoriduttore
 Geared motor
 Getriebemotor

P ₁ [kW]	n ₂ [rpm]	Tipo - Size - Größe	i _r	M ₂ [Nm]	FS	MRO [kg]	FRO [kg]	F _{r2} [N]	J _m × 10 ⁻³	J ₁ × 10 ⁻⁴	
0,25	62	MRO 02 - 71A4	22,73	37	3	9,4	4,4	3400	5	0,525	
	61	MRO 32 - 71A4	23,03	38	>3	20	15	7700	5	3,2506	
		MRO 22 - 63C4	23,03	38	>3	16	11	5000	4	3,0523	
		MRO 22 - 71A4	23,03	38	>3	16	11	5000	5	3,0523	
		57	MRO 32 - 71A4	24,39	40	>3	20	15	8300	5	3,3409
		MRO 22 - 63C4	24,61	40	>3	16	11	5500	4	3,1062	
		MRO 22 - 71A4	24,61	40	>3	16	11	5500	5	3,1062	
		54	MRO 02 - 63C4	24,41	40	2,5	9,4	4,4	3700	4	0,557
		MRO 02 - 71A4	24,41	40	2,5	9,4	4,4	3700	5	0,557	
		54	MRO 12 - 63C4	25,92	42	>3	12	7	4850	4	1,8225
		MRO 12 - 71A4	25,92	42	>3	12	7	4850	5	1,8225	
		53	MRO 22 - 63C4	26,42	43	>3	16	11	5450	4	3,0234
		MRO 22 - 71A4	26,42	43	>3	16	11	5450	5	3,0234	
		52	MRO 32 - 71A4	27,01	44	>3	20	15	8400	5	3,1801
		MRO 02 - 63C4	27,13	44	2,5	9,4	4,4	3700	4	0,518	
		MRO 02 - 71A4	27,13	44	2,5	9,4	4,4	3700	5	0,518	
		51	MRO 12 - 63C4	27,64	45	>3	12	7	4550	4	1,772
		MRO 12 - 71A4	27,64	45	>3	12	7	4550	5	1,772	
		45	MRO 12 - 63C4	31,45	52	>3	12	7	4800	4	1,7418
		MRO 12 - 71A4	31,45	52	>3	12	7	4800	5	1,7418	
		44	MRO 02 - 63C4	31,88	52	1,9	9,4	4,4	3950	4	0,498
		MRO 02 - 71A4	31,88	52	1,9	9,4	4,4	3950	5	0,498	
		43	MRO 32 - 71A4	32,3	53	>3	20	15	9050	5	3,058
		MRO 22 - 63C4	32,3	53	>3	16	11	5900	4	2,9572	
		MRO 22 - 71A4	32,3	53	>3	16	11	5900	5	2,9572	
		43	MRO 12 - 63C4	32,73	54	>3	12	7	5200	4	1,7591
		MRO 12 - 71A4	32,73	54	>3	12	7	5200	5	1,7591	
		42	MRO 02 - 63C4	32,73	54	1,9	9,4	4,4	4150	4	0,512
		MRO 02 - 71A4	32,73	54	1,9	9,4	4,4	4150	5	0,512	
		MRO 22 - 63C4	33,64	55	>3	16	11	6100	4	2,9816	
		MRO 22 - 71A4	33,64	55	>3	16	11	6100	5	2,9816	
38		MRO 32 - 71A4	36,69	60	>3	20	15	9950	5	3,0718	
		MRO 22 - 63C4	37,06	61	>3	16	11	6350	4	2,9425	
		MRO 22 - 71A4	37,06	61	>3	16	11	6350	5	2,9425	
		MRO 02 - 63C4	36,73	60	1,7	9,4	4,4	4350	4	0,509	
		MRO 02 - 71A4	36,73	60	1,7	9,4	4,4	4350	5	0,509	
		37	MRO 32 - 71A4	37,89	62	>3	20	15	9800	5	3,0222
		MRO 02 - 63C4	38,05	62	1,6	9,4	4,4	4200	4	0,494	
		MRO 02 - 71A4	38,05	62	1,6	9,4	4,4	4200	5	0,494	
36		MRO 12 - 63C4	38,76	63	>3	12	7	5300	4	1,732	
		MRO 12 - 71A4	38,76	63	>3	12	7	5300	5	1,732	
31		MRO 32 - 71A4	45,05	74	>3	20	15	9800	5	2,9882	
		MRO 12 - 63C4	45,9	75	2,3	12	7	5700	4	1,7254	
		MRO 12 - 71A4	45,9	75	2,3	12	7	5700	5	1,7254	
		MRO 02 - 63C4	45,9	75	1,3	9,4	4,4	4900	4	0,491	
		MRO 02 - 71A4	45,9	75	1,3	9,4	4,4	4900	5	0,491	
		30	MRO 22 - 63C4	47,18	77	>3	16	11	6400	4	2,9213
		MRO 22 - 71A4	47,18	77	>3	16	11	6400	5	2,9213	
		27	MRO 32 - 71A4	51,46	84	>3	20	15	9800	5	2,9671
		MRO 22 - 63C4	51,93	85	>3	16	11	6450	4	2,9144	



MRO-2 - 1400 rpm
 Motoriduttore
 Geared motor
 Getriebemotor

P ₁ [kW]	n ₂ [rpm]	Tipo - Size - Größe	i _r	M ₂ [Nm]	FS	MRO [kg]	FRO [kg]	F _{r2} [N]	J _m × 10 ⁻³	J ₁ × 10 ⁻⁴
0,25	27	MRO 22 - 71A4	51,93	85	>3	16	11	6450	5	2,9144
		MRO 02 - 63C4	51,51	84	1,2	9,4	4,4	4900	4	0,49
		MRO 02 - 71A4	51,51	84	1,2	9,4	4,4	4900	5	0,49
	26	MRO 12 - 63C4	54,71	90	1,7	12	7	5750	4	1,7202
		MRO 12 - 71A4	54,71	90	1,7	12	7	5750	5	1,7202
0,37	278	MRO 12 - 71B4	5,03	12	>3	12,8	7	2300	8	3,2008
	270	MRO 32 - 71B4	5,18	13	>3	20,8	15	4800	8	9,0749
		MRO 22 - 71B4	5,18	13	>3	16,8	11	3150	8	5,8944
		MRO 02 - 71B4	5,18	13	>3	10,2	4,4	1700	8	1,214
	197	MRO 12 - 71B4	7,09	17	>3	12,8	7	2450	8	2,6978
	195	MRO 02 - 71B4	7,19	17	>3	10,2	4,4	2000	8	1,015
	192	MRO 32 - 71B4	7,28	18	>3	20,8	15	5650	8	6,7749
		MRO 22 - 71B4	7,28	18	>3	16,8	11	3200	8	4,792
	167	MRO 22 - 71B4	8,36	20	>3	16,8	11	3450	8	4,5033
	164	MRO 32 - 71B4	8,54	21	>3	20,8	15	6000	8	6,07
	163	MRO 02 - 71B4	8,58	21	>3	10,2	4,4	2200	8	0,944
	160	MRO 12 - 71B4	8,74	21	>3	12,8	7	2700	8	2,5046
	132	MRO 12 - 71B4	10,57	26	>3	12,8	7	2700	8	2,0326
	129	MRO 32 - 71B4	10,88	26	>3	20,8	15	6000	8	4,2665
		MRO 22 - 71B4	10,88	26	>3	16,8	11	3700	8	3,5463
		MRO 02 - 71B4	10,88	26	>3	10,2	4,4	2300	8	0,639
	121	MRO 32 - 71B4	11,6	28	>3	20,8	15	6400	8	4,9874
	120	MRO 22 - 71B4	11,71	28	>3	16,8	11	4050	8	3,9507
	113	MRO 12 - 71B4	12,34	30	>3	12,8	7	3550	8	2,2731
	94	MRO 12 - 71B4	14,9	36	>3	12,8	7	3350	8	1,9187
	93	MRO 02 - 71B4	15,1	37	>3	10,2	4,4	2850	8	0,593
	91	MRO 32 - 71B4	15,31	37	>3	20,8	15	6450	8	3,7457
		MRO 22 - 71B4	15,31	37	>3	16,8	11	4100	8	3,2966
	88	MRO 12 - 71B4	15,91	39	>3	12,8	7	3650	8	1,8416
	86	MRO 32 - 71B4	16,36	40	>3	20,8	15	6500	8	3,4806
		MRO 22 - 71B4	16,36	40	>3	16,8	11	4100	8	3,1625
		MRO 02 - 71B4	16,36	40	2,5	10,2	4,4	3000	8	0,545
	80	MRO 22 - 71B4	17,56	43	>3	16,8	11	4450	8	3,2313
	78	MRO 32 - 71B4	17,95	44	>3	20,8	15	6900	8	3,586
		MRO 02 - 71B4	18,03	44	2,5	10,2	4,4	3100	8	0,578
	76	MRO 12 - 71B4	18,37	45	>3	12,8	7	3750	8	1,8749
	66	MRO 32 - 71B4	21,35	52	>3	20,8	15	7550	8	3,4347
		MRO 12 - 71B4	21,75	53	>3	12,8	7	4350	8	1,8457
	64	MRO 02 - 71B4	21,75	53	2,1	10,2	4,4	3400	8	0,564
		MRO 22 - 71B4	22,35	54	>3	16,8	11	5000	8	3,1366
	62	MRO 12 - 71B4	22,42	54	>3	12,8	7	4100	8	1,7913
		MRO 02 - 71B4	22,73	55	2	10,2	4,4	3400	8	0,525
		MRO 32 - 71B4	23,03	56	>3	20,8	15	7700	8	3,2506
	61	MRO 22 - 71B4	23,03	56	>3	16,8	11	5000	8	3,0523
		MRO 32 - 71B4	24,39	59	>3	20,8	15	8300	8	3,3409
		MRO 22 - 71B4	24,61	60	>3	16,8	11	5500	8	3,1062
	57	MRO 02 - 71B4	24,41	59	1,7	10,2	4,4	3700	8	0,557
MRO 12 - 71B4		25,92	63	2,4	12,8	7	4850	8	1,8225	
53	MRO 22 - 71B4	26,42	64	>3	16,8	11	5450	8	3,0234	
52	MRO 32 - 71B4	27,01	65	>3	20,8	15	8400	8	3,1801	



MRO-2 - 1400 rpm
 Motoriduttore
 Geared motor
 Getriebemotor

P ₁ [kW]	n ₂ [rpm]	Tipo - Size - Größe	i _r	M ₂ [Nm]	FS	MRO [kg]	FRO [kg]	F _{r2} [N]	J _m × 10 ⁻³	J ₁ × 10 ⁻⁴
0,37	52	MRO 02 - 71B4	27,13	66	1,7	10,2	4,4	3700	8	0,518
	51	MRO 12 - 71B4	27,64	67	3	12,8	7	4550	8	1,772
	45	MRO 12 - 71B4	31,45	76	2,6	12,8	7	4800	8	1,7418
	44	MRO 02 - 71B4	31,88	77	1,3	10,2	4,4	3950	8	0,498
	43	MRO 32 - 71B4	32,3	78	>3	20,8	15	9050	8	3,058
		MRO 22 - 71B4	32,3	78	>3	16,8	11	5900	8	2,9572
		MRO 12 - 71B4	32,73	79	2,1	12,8	7	5200	8	1,7591
	42	MRO 02 - 71B4	32,73	79	1,3	10,2	4,4	4150	8	0,512
		MRO 22 - 71B4	33,64	82	>3	16,8	11	6100	8	2,9816
	38	MRO 32 - 71B4	36,69	89	>3	20,8	15	9950	8	3,0718
		MRO 22 - 71B4	37,06	90	>3	16,8	11	6350	8	2,9425
	37	MRO 02 - 71B4	36,73	89	1,1	10,2	4,4	4350	8	0,509
		MRO 32 - 71B4	37,89	92	>3	20,8	15	9800	8	3,0222
	36	MRO 02 - 71B4	38,05	92	1,1	10,2	4,4	4200	8	0,494
		MRO 12 - 71B4	38,76	94	2,1	12,8	7	5300	8	1,732
	31	MRO 32 - 71B4	45,05	109	>3	20,8	15	9800	8	2,9882
		MRO 12 - 71B4	45,9	111	1,5	12,8	7	5700	8	1,7254
	30	MRO 02 - 71B4	45,9	111	0,9	10,2	4,4	4900	8	0,491
		MRO 22 - 71B4	47,18	114	2,9	16,8	11	6400	8	2,9213
	27	MRO 32 - 71B4	51,46	125	>3	20,8	15	9800	8	2,9671
MRO 22 - 71B4		51,93	126	2,4	16,8	11	6450	8	2,9144	
26	MRO 02 - 71B4	51,51	125	0,8	10,2	4,4	4900	8	0,49	
	MRO 12 - 71B4	54,71	133	1,1	12,8	7	5750	8	1,7202	
0,55	278	MRO 12 - 71C4	5,03	18	>3	13,5	7	2300	9	3,2008
	270	MRO 12 - 80A4	5,03	18	>3	15,1	7	2300	14	3,2008
		MRO 32 - 71C4	5,18	19	>3	21,5	15	4800	9	9,0749
	270	MRO 32 - 80A4	5,18	19	>3	23,1	15	4800	14	9,0749
		MRO 22 - 71C4	5,18	19	>3	17,5	11	3150	9	5,8944
	270	MRO 22 - 80A4	5,18	19	>3	19,1	11	3150	14	5,8944
		MRO 02 - 71C4	5,18	19	>3	10,9	4,4	1700	8	1,214
	197	MRO 02 - 80A4	5,18	19	>3	12,5	4,4	1700	14	1,214
		MRO 12 - 71C4	7,09	26	>3	13,5	7	2450	9	2,6978
	197	MRO 12 - 80A4	7,09	26	>3	15,1	7	2450	14	2,6978
		MRO 02 - 71C4	7,19	26	>3	10,9	4,4	2000	9	1,015
	195	MRO 02 - 80A4	7,19	26	>3	12,5	4,4	2000	14	1,015
		MRO 32 - 71C4	7,28	26	>3	21,5	15	5650	9	6,7749
	192	MRO 32 - 80A4	7,28	26	>3	23,1	15	5650	14	6,7749
		MRO 22 - 71C4	7,28	26	>3	17,5	11	3200	9	4,792
	167	MRO 22 - 80A4	7,28	26	>3	19,1	11	3200	14	4,792
		MRO 22 - 71C4	8,36	30	>3	17,5	11	3450	9	4,5033
	164	MRO 22 - 80A4	8,36	30	>3	19,1	11	3450	14	4,5033
		MRO 32 - 71C4	8,54	31	>3	21,5	15	6000	9	6,07
	163	MRO 32 - 80A4	8,54	31	>3	23,1	15	6000	14	6,07
MRO 02 - 71C4		8,58	31	>3	10,9	4,4	2200	9	0,944	
160	MRO 02 - 80A4	8,58	31	>3	12,5	4,4	2200	14	0,944	
	MRO 12 - 71C4	8,74	31	>3	13,5	7	2700	9	2,5046	
132	MRO 12 - 80A4	8,74	31	>3	15,1	7	2700	14	2,5046	
	MRO 12 - 71C4	10,57	38	>3	13,5	7	2700	9	2,0326	
129	MRO 12 - 80A4	10,57	38	>3	15,1	7	2700	14	2,0326	
	MRO 32 - 71C4	10,88	39	>3	21,5	15	6000	9	4,2665	



MRO-2 - 1400 rpm
 Motoriduttore
 Geared motor
 Getriebemotor

P ₁ [kW]	n ₂ [rpm]	Tipo - Size - Größe	i _r	M ₂ [Nm]	FS	MRO [kg]	FRO [kg]	F _{r2} [N]	J _m × 10 ⁻⁴	J ₁ × 10 ⁻⁴
0,55	129	MRO 32 - 80A4	10,88	39	>3	23,1	15	6000	14	4,2665
		MRO 22 - 71C4	10,88	39	>3	17,5	11	3700	9	3,5463
		MRO 22 - 80A4	10,88	39	>3	19,1	11	3700	14	3,5463
		MRO 02 - 71C4	10,88	39	>3	10,9	4,4	2300	9	0,639
	121	MRO 02 - 80A4	10,88	39	>3	12,5	4,4	2300	14	0,639
		MRO 32 - 71C4	11,6	42	>3	21,5	15	6400	9	4,9874
	120	MRO 32 - 80A4	11,6	42	>3	23,1	15	6400	14	4,9874
		MRO 22 - 71C4	11,71	42	>3	17,5	11	4050	9	3,9507
	113	MRO 22 - 80A4	11,71	42	>3	19,1	11	4050	14	3,9507
		MRO 12 - 71C4	12,34	44	>3	13,5	7	3550	9	2,2731
	94	MRO 12 - 80A4	12,34	44	>3	15,1	7	3550	14	2,2731
		MRO 12 - 71C4	14,9	54	>3	13,5	7	3350	9	1,9187
	93	MRO 12 - 80A4	14,9	54	>3	15,1	7	3350	14	1,9187
		MRO 02 - 71C4	15,1	54	2	10,9	4,4	2850	9	0,593
	91	MRO 02 - 80A4	15,1	54	2	12,5	4,4	2850	14	0,593
		MRO 32 - 71C4	15,31	55	>3	21,5	15	6450	9	3,7457
	88	MRO 32 - 80A4	15,31	55	>3	23,1	15	6450	14	3,7457
		MRO 22 - 71C4	15,31	55	>3	17,5	11	4100	9	3,2966
	86	MRO 22 - 80A4	15,31	55	>3	19,1	11	4100	14	3,2966
		MRO 12 - 71C4	15,91	57	3	13,5	7	3650	9	1,8416
	80	MRO 12 - 80A4	15,91	57	3	15,1	7	3650	14	1,8416
		MRO 32 - 71C4	16,36	59	>3	21,5	15	6500	9	3,4806
	78	MRO 32 - 80A4	16,36	59	>3	23,1	15	6500	14	3,4806
		MRO 22 - 71C4	16,36	59	>3	17,5	11	4100	9	3,1625
	76	MRO 22 - 80A4	16,36	59	>3	19,1	11	4100	14	3,1625
		MRO 02 - 71C4	16,36	59	1,7	10,9	4,4	3000	9	0,545
	66	MRO 02 - 80A4	16,36	59	1,7	12,5	4,4	3000	14	0,545
		MRO 22 - 71C4	17,56	63	>3	17,5	11	4450	9	3,2313
	64	MRO 22 - 80A4	17,56	63	>3	19,1	11	4450	14	3,2313
		MRO 32 - 71C4	17,95	65	>3	21,5	15	6900	9	3,586
	63	MRO 32 - 80A4	17,95	65	>3	23,1	15	6900	14	3,586
		MRO 02 - 71C4	18,03	65	1,7	10,9	4,4	3100	9	0,578
	62	MRO 02 - 80A4	18,03	65	1,7	12,5	4,4	3100	14	0,578
		MRO 12 - 71C4	18,37	66	>3	13,5	7	3750	9	1,8749
	61	MRO 12 - 80A4	18,37	66	>3	15,1	7	3750	14	1,8749
		MRO 32 - 71C4	21,35	77	>3	21,5	15	7550	9	3,4347
	61	MRO 32 - 80A4	21,35	77	>3	23,1	15	7550	14	3,4347
		MRO 12 - 71C4	21,75	78	2,2	13,5	7	4350	9	1,8457
	61	MRO 12 - 80A4	21,75	78	2,2	15,1	7	4350	14	1,8457
		MRO 02 - 71C4	21,75	78	1,4	10,9	4,4	3400	9	0,564
	61	MRO 02 - 80A4	21,75	78	1,4	12,5	4,4	3400	14	0,564
		MRO 22 - 71C4	22,35	81	>3	17,5	11	5000	9	3,1366
	61	MRO 22 - 80A4	22,35	81	>3	19,1	11	5000	14	3,1366
		MRO 12 - 71C4	22,42	81	2,5	13,5	7	4100	9	1,7913
	61	MRO 12 - 80A4	22,42	81	2,5	15,1	7	4100	14	1,7913
		MRO 02 - 71C4	22,73	82	1,3	10,9	4,4	3400	9	0,525
	61	MRO 02 - 80A4	22,73	82	1,3	12,5	4,4	3400	14	0,525
		MRO 32 - 71C4	23,03	83	>3	21,5	15	7700	9	3,2506
	61	MRO 32 - 80A4	23,03	83	>3	23,1	15	7700	14	3,2506
		MRO 22 - 71C4	23,03	83	>3	17,5	11	5000	9	3,0523



MRO-2 - 1400 rpm
 Motoriduttore
 Geared motor
 Getriebemotor

P ₁ [kW]	n ₂ [rpm]	Tipo - Size - Größe	i _r	M ₂ [Nm]	FS	MRO [kg]	FRO [kg]	F _{r2} [N]	J _m × 10 ⁻³	J ₁ × 10 ⁻⁴
0,55	61	MRO 22 - 80A4	23,03	83	>3	19,1	11	5000	14	3,0523
	57	MRO 32 - 71C4	24,39	88	>3	21,5	15	8300	9	3,3409
		MRO 32 - 80A4	24,39	88	>3	23,1	15	8300	14	3,3409
		MRO 22 - 71C4	24,61	89	>3	17,5	11	5500	9	3,1062
		MRO 22 - 80A4	24,61	89	>3	19,1	11	5500	14	3,1062
		MRO 02 - 71C4	24,41	88	1,1	10,9	4,4	3700	9	0,557
		MRO 02 - 80A4	24,41	88	1,1	12,5	4,4	3700	14	0,557
	54	MRO 12 - 71C4	25,92	93	1,6	13,5	7	4850	9	1,8225
		MRO 12 - 80A4	25,92	93	1,6	15,1	7	4850	14	1,8225
	53	MRO 22 - 71C4	26,42	95	>3	17,5	11	5450	9	3,0234
		MRO 22 - 80A4	26,42	95	>3	19,1	11	5450	14	3,0234
	52	MRO 32 - 71C4	27,01	97	>3	21,5	15	8400	9	3,1801
		MRO 32 - 80A4	27,01	97	>3	23,1	15	8400	14	3,1801
		MRO 02 - 71C4	27,13	98	1,1	10,9	4,4	3700	9	0,518
		MRO 02 - 80A4	27,13	98	1,1	12,5	4,4	3700	14	0,518
	51	MRO 12 - 71C4	27,64	100	2	13,5	7	4550	9	1,772
		MRO 12 - 80A4	27,64	100	2	15,1	7	4550	14	1,772
	45	MRO 12 - 71C4	31,45	113	1,8	13,5	7	4800	9	1,7418
		MRO 12 - 80A4	31,45	113	1,8	15,1	7	4800	14	1,7418
	44	MRO 02 - 71C4	31,88	115	0,9	10,9	4,4	3950	9	0,498
		MRO 02 - 80A4	31,88	115	0,9	12,5	4,4	3950	14	0,498
	43	MRO 32 - 71C4	32,3	116	>3	21,5	15	9050	9	3,058
		MRO 32 - 80A4	32,3	116	>3	23,1	15	9050	14	3,058
		MRO 22 - 71C4	32,3	116	2,8	17,5	11	5900	9	2,9572
		MRO 22 - 80A4	32,3	116	2,8	19,1	11	5900	14	2,9572
		MRO 12 - 71C4	32,73	118	1,4	13,5	7	5200	9	1,7591
		MRO 12 - 80A4	32,73	118	1,4	15,1	7	5200	14	1,7591
	42	MRO 02 - 71C4	32,73	118	0,8	10,9	4,4	4150	9	0,512
		MRO 02 - 80A4	32,73	118	0,8	12,5	4,4	4150	14	0,512
		MRO 22 - 71C4	33,64	121	2,7	17,5	11	6100	9	2,9816
		MRO 22 - 80A4	33,64	121	2,7	19,1	11	6100	14	2,9816
	38	MRO 32 - 71C4	36,69	132	>3	21,5	15	9950	9	3,0718
		MRO 32 - 80A4	36,69	132	>3	23,1	15	9950	14	3,0718
		MRO 22 - 71C4	37,06	134	2,5	17,5	11	6350	9	2,9425
		MRO 22 - 80A4	37,06	134	2,5	19,1	11	6350	14	2,9425
	37	MRO 32 - 71C4	37,89	137	>3	21,5	15	9800	9	3,0222
		MRO 32 - 80A4	37,89	137	>3	23,1	15	9800	14	3,0222
	36	MRO 12 - 71C4	38,76	140	1,4	13,5	7	5300	9	1,732
		MRO 12 - 80A4	38,76	140	1,4	15,1	7	5300	14	1,732
	31	MRO 32 - 71C4	45,05	162	>3	21,5	15	9800	9	2,9882
		MRO 32 - 80A4	45,05	162	>3	23,1	15	9800	14	2,9882
		MRO 12 - 71C4	45,9	165	1	13,5	7	5700	9	1,7254
MRO 12 - 80A4		45,9	165	1	15,1	7	5700	14	1,7254	
30	MRO 22 - 71C4	47,18	170	1,9	17,5	11	6400	9	2,9213	
	MRO 22 - 80A4	47,18	170	1,9	19,1	11	6400	14	2,9213	
27	MRO 32 - 71C4	51,46	185	2,7	21,5	15	9800	9	2,9671	
	MRO 32 - 80A4	51,46	185	2,7	23,1	15	9800	14	2,9671	
	MRO 22 - 71C4	51,93	187	1,6	17,5	11	6450	9	2,9144	
	MRO 22 - 80A4	51,93	187	1,6	19,1	11	6450	14	2,9144	
0,75	278	MRO 12 - 80B4	5,03	25	>3	16,1	7	2300	17	3,2008



MRO-2 - 1400 rpm
 Motoriduttore
 Geared motor
 Getriebemotor

P ₁ [kW]	n ₂ [rpm]	Tipo - Size - Größe	i _r	M ₂ [Nm]	FS	MRO [kg]	FRO [kg]	F _{r2} [N]	J _m × 10 ⁻⁴	J ₁ × 10 ⁻⁴
0,75	270	MRO 32 - 80B4	5,18	25	>3	24,1	15	4800	17	9,0749
		MRO 22 - 80B4	5,18	25	>3	20,1	11	3150	17	5,8944
		MRO 02 - 80B4	5,18	25	>3	13,5	4,4	1700	17	1,214
	197	MRO 12 - 80B4	7,09	35	>3	16,1	7	2450	17	2,6978
	195	MRO 02 - 80B4	7,19	35	>3	13,5	4,4	2000	17	1,015
	192	MRO 32 - 80B4	7,28	36	>3	24,1	15	5650	17	6,7749
		MRO 22 - 80B4	7,28	36	>3	20,1	11	3200	17	4,792
	167	MRO 22 - 80B4	8,36	41	>3	20,1	11	3450	17	4,5033
	164	MRO 32 - 80B4	8,54	42	>3	24,1	15	6000	17	6,07
	163	MRO 02 - 80B4	8,58	42	2,6	13,5	4,4	2200	17	0,944
	160	MRO 12 - 80B4	8,74	43	>3	16,1	7	2700	17	2,5046
	132	MRO 12 - 80B4	10,57	52	>3	16,1	7	2700	17	2,0326
	129	MRO 32 - 80B4	10,88	53	>3	24,1	15	6000	17	4,2665
		MRO 22 - 80B4	10,88	53	>3	20,1	11	3700	17	3,5463
		MRO 02 - 80B4	10,88	53	2,2	13,5	4,4	2300	17	0,639
	121	MRO 32 - 80B4	11,6	57	>3	24,1	15	6400	17	4,9874
	120	MRO 22 - 80B4	11,71	58	>3	20,1	11	4050	17	3,9507
	113	MRO 12 - 80B4	12,34	61	2,5	16,1	7	3550	17	2,2731
	94	MRO 12 - 80B4	14,9	73	2,7	16,1	7	3350	17	1,9187
	93	MRO 02 - 80B4	15,1	74	1,5	13,5	4,4	2850	17	0,593
	91	MRO 32 - 80B4	15,31	75	>3	24,1	15	6450	17	3,7457
		MRO 22 - 80B4	15,31	75	>3	20,1	11	4100	17	3,2966
	88	MRO 12 - 80B4	15,91	78	2,2	16,1	7	3650	17	1,8416
	86	MRO 32 - 80B4	16,36	80	>3	24,1	15	6500	17	3,4806
		MRO 22 - 80B4	16,36	80	>3	20,1	11	4100	17	3,1625
		MRO 02 - 80B4	16,36	80	1,2	13,5	4,4	3000	17	0,545
	80	MRO 22 - 80B4	17,56	86	>3	20,1	11	4450	17	3,2313
	78	MRO 32 - 80B4	17,95	88	>3	24,1	15	6900	17	3,586
		MRO 02 - 80B4	18,03	89	1,2	13,5	4,4	3100	17	0,578
	76	MRO 12 - 80B4	18,37	90	2,2	16,1	7	3750	17	1,8749
	66	MRO 32 - 80B4	21,35	105	>3	24,1	15	7550	17	3,4347
	64	MRO 12 - 80B4	21,75	107	1,6	16,1	7	4350	17	1,8457
		MRO 02 - 80B4	21,75	107	1	13,5	4,4	3400	17	0,564
	63	MRO 22 - 80B4	22,35	110	>3	20,1	11	5000	17	3,1366
	62	MRO 12 - 80B4	22,42	110	1,8	16,1	7	4100	17	1,7913
		MRO 02 - 80B4	22,73	112	1	13,5	4,4	3400	17	0,525
	61	MRO 32 - 80B4	23,03	113	>3	24,1	15	7700	17	3,2506
		MRO 22 - 80B4	23,03	113	2,9	20,1	11	5000	17	3,0523
	57	MRO 32 - 80B4	24,39	120	>3	24,1	15	8300	17	3,3409
		MRO 22 - 80B4	24,61	121	2,5	20,1	11	5500	17	3,1062
		MRO 02 - 80B4	24,41	120	0,8	13,5	4,4	3700	17	0,557
	54	MRO 12 - 80B4	25,92	127	1,2	16,1	7	4850	17	1,8225
	53	MRO 22 - 80B4	26,42	130	2,5	20,1	11	5450	17	3,0234
	52	MRO 32 - 80B4	27,01	133	>3	24,1	15	8400	17	3,1801
		MRO 02 - 80B4	27,13	133	0,8	13,5	4,4	3700	17	0,518
	51	MRO 12 - 80B4	27,64	136	1,5	16,1	7	4550	17	1,772
	45	MRO 12 - 80B4	31,45	155	1,3	16,1	7	4800	17	1,7418
	43	MRO 32 - 80B4	32,3	159	>3	24,1	15	9050	17	3,058
		MRO 22 - 80B4	32,3	159	2,1	20,1	11	5900	17	2,9572
		MRO 12 - 80B4	32,73	161	1,1	16,1	7	5200	17	1,7591



MRO-2 - 1400 rpm
 Motoriduttore
 Geared motor
 Getriebemotor

P ₁ [kW]	n ₂ [rpm]	Tipo - Size - Größe	i _r	M ₂ [Nm]	FS	MRO [kg]	FRO [kg]	F _{r2} [N]	J _m × 10 ⁻⁴	J ₁ × 10 ⁻⁴
0,75	42	MRO 22 - 80B4	33,64	165	2	20,1	11	6100	17	2,9816
	38	MRO 32 - 80B4	36,69	180	2,8	24,1	15	9950	17	3,0718
		MRO 22 - 80B4	37,06	182	1,8	20,1	11	6350	17	2,9425
	37	MRO 32 - 80B4	37,89	186	2,7	24,1	15	9800	17	3,0222
	36	MRO 12 - 80B4	38,76	190	1,1	16,1	7	5300	17	1,732
	31	MRO 32 - 80B4	45,05	221	2,3	24,1	15	9800	17	2,9882
	30	MRO 22 - 80B4	47,18	232	1,4	20,1	11	6400	17	2,9213
	27	MRO 32 - 80B4	51,46	253	2	24,1	15	9800	17	2,9671
		MRO 22 - 80B4	51,93	255	1,2	20,1	11	6450	17	2,9144
1,1	278	MRO 12 - 80C4	5,03	36	>3	18	7	2300	23	3,2008
		MRO 12 - 90S4	5,03	36	>3	18,7	7	2300	33	3,2008
	270	MRO 32 - 80C4	5,18	37	>3	26	15	4800	23	9,0749
		MRO 32 - 90S4	5,18	37	>3	26,7	15	4800	33	9,0749
		MRO 22 - 80C4	5,18	37	>3	22	11	3150	23	5,8944
		MRO 22 - 90S4	5,18	37	>3	22,7	11	3150	33	5,8944
		MRO 02 - 80C4	5,18	37	2,8	15,4	4,4	1700	23	1,214
		MRO 02 - 90S4	5,18	37	2,8	16,1	4,4	1700	33	1,214
	197	MRO 12 - 80C4	7,09	51	>3	18	7	2450	23	2,6978
		MRO 12 - 90S4	7,09	51	>3	18,7	7	2450	33	2,6978
	195	MRO 02 - 80C4	7,19	52	2,1	15,4	4,4	2000	23	1,015
		MRO 02 - 90S4	7,19	52	2,1	16,1	4,4	2000	33	1,015
	192	MRO 32 - 80C4	7,28	52	>3	26	15	5650	23	6,7749
		MRO 32 - 90S4	7,28	52	>3	26,7	15	5650	33	6,7749
		MRO 22 - 80C4	7,28	52	>3	22	11	3200	23	4,792
		MRO 22 - 90S4	7,28	52	>3	22,7	11	3200	33	4,792
	167	MRO 22 - 80C4	8,36	60	>3	22	11	3450	23	4,5033
		MRO 22 - 90S4	8,36	60	>3	22,7	11	3450	33	4,5033
	164	MRO 32 - 80C4	8,54	62	>3	26	15	6000	23	6,07
		MRO 32 - 90S4	8,54	62	>3	26,7	15	6000	33	6,07
	163	MRO 02 - 80C4	8,58	62	1,8	15,4	4,4	2200	23	0,944
		MRO 02 - 90S4	8,58	62	1,8	16,1	4,4	2200	33	0,944
	160	MRO 12 - 80C4	8,74	63	2,9	18	7	2700	23	2,5046
		MRO 12 - 90S4	8,74	63	2,9	18,7	7	2700	33	2,5046
	132	MRO 12 - 80C4	10,57	76	2,6	18	7	2700	23	2,0326
		MRO 12 - 90S4	10,57	76	2,6	18,7	7	2700	33	2,0326
	129	MRO 32 - 80C4	10,88	78	>3	26	15	6000	23	4,2665
		MRO 32 - 90S4	10,88	78	>3	26,7	15	6000	33	4,2665
		MRO 22 - 80C4	10,88	78	>3	22	11	3700	23	3,5463
		MRO 22 - 90S4	10,88	78	>3	22,7	11	3700	33	3,5463
		MRO 02 - 80C4	10,88	78	1,5	15,4	4,4	2300	23	0,639
		MRO 02 - 90S4	10,88	78	1,5	16,1	4,4	2300	33	0,639
	121	MRO 32 - 80C4	11,6	84	>3	26	15	6400	23	4,9874
		MRO 32 - 90S4	11,6	84	>3	26,7	15	6400	33	4,9874
	120	MRO 22 - 80C4	11,71	84	>3	22	11	4050	23	3,9507
		MRO 22 - 90S4	11,71	84	>3	22,7	11	4050	33	3,9507
113	MRO 12 - 80C4	12,34	89	1,7	18	7	3550	23	2,2731	
	MRO 12 - 90S4	12,34	89	1,7	18,7	7	3550	33	2,2731	
94	MRO 12 - 80C4	14,9	107	1,9	18	7	3350	23	1,9187	
	MRO 12 - 90S4	14,9	107	1,9	18,7	7	3350	33	1,9187	
93	MRO 02 - 80C4	15,1	109	1	15,4	4,4	2850	23	0,593	



MRO-2 - 1400 rpm
 Motoriduttore
 Geared motor
 Getriebemotor

P ₁ [kW]	n ₂ [rpm]	Tipo - Size - Größe	i _r	M ₂ [Nm]	FS	MRO [kg]	FRO [kg]	F _{r2} [N]	J _m × 10 ⁻³	J ₁ × 10 ⁻⁴
1,1	93	MRO 02 - 90S4	15,1	109	1	16,1	4,4	2850	33	0,593
	91	MRO 32 - 80C4	15,31	110	>3	26	15	6450	23	3,7457
		MRO 32 - 90S4	15,31	110	>3	26,7	15	6450	33	3,7457
		MRO 22 - 80C4	15,31	110	3	22	11	4100	23	3,2966
		MRO 22 - 90S4	15,31	110	3	22,7	11	4100	33	3,2966
	88	MRO 12 - 80C4	15,91	115	1,5	18	7	3650	23	1,8416
		MRO 12 - 90S4	15,91	115	1,5	18,7	7	3650	33	1,8416
	86	MRO 32 - 80C4	16,36	118	>3	26	15	6500	23	3,4806
		MRO 32 - 90S4	16,36	118	>3	26,7	15	6500	33	3,4806
		MRO 22 - 80C4	16,36	118	2,8	22	11	4100	23	3,1625
		MRO 22 - 90S4	16,36	118	2,8	22,7	11	4100	33	3,1625
		MRO 02 - 80C4	16,36	118	0,8	15,4	4,4	3000	23	0,545
		MRO 02 - 90S4	16,36	118	0,8	16,1	4,4	3000	33	0,545
	80	MRO 22 - 80C4	17,56	127	2,6	22	11	4450	23	3,2313
		MRO 22 - 90S4	17,56	127	2,6	22,7	11	4450	33	3,2313
	78	MRO 32 - 80C4	17,95	129	>3	26	15	6900	23	3,586
		MRO 32 - 90S4	17,95	129	>3	26,7	15	6900	33	3,586
		MRO 02 - 80C4	18,03	130	0,8	15,4	4,4	3100	23	0,578
		MRO 02 - 90S4	18,03	130	0,8	16,1	4,4	3100	33	0,578
	76	MRO 12 - 80C4	18,37	132	1,5	18	7	3750	23	1,8749
		MRO 12 - 90S4	18,37	132	1,5	18,7	7	3750	33	1,8749
	66	MRO 32 - 80C4	21,35	154	>3	26	15	7550	23	3,4347
		MRO 32 - 90S4	21,35	154	>3	26,7	15	7550	33	3,4347
	64	MRO 12 - 80C4	21,75	157	1,1	18	7	4350	23	1,8457
		MRO 12 - 90S4	21,75	157	1,1	18,7	7	4350	33	1,8457
	63	MRO 22 - 80C4	22,35	161	2	22	11	5000	23	3,1366
		MRO 22 - 90S4	22,35	161	2	22,7	11	5000	33	3,1366
	62	MRO 12 - 80C4	22,42	162	1,2	18	7	4100	23	1,7913
		MRO 12 - 90S4	22,42	162	1,2	18,7	7	4100	33	1,7913
	61	MRO 32 - 80C4	23,03	166	>3	26	15	7700	23	3,2506
		MRO 32 - 90S4	23,03	166	>3	26,7	15	7700	33	3,2506
		MRO 22 - 80C4	23,03	166	2	22	11	5000	23	3,0523
		MRO 22 - 90S4	23,03	166	2	22,7	11	5000	33	3,0523
	57	MRO 32 - 80C4	24,39	176	2,8	26	15	8300	23	3,3409
		MRO 32 - 90S4	24,39	176	2,8	26,7	15	8300	33	3,3409
		MRO 22 - 80C4	24,61	177	1,7	22	11	5500	23	3,1062
		MRO 22 - 90S4	24,61	177	1,7	22,7	11	5500	33	3,1062
	54	MRO 12 - 80C4	25,92	187	0,8	18	7	4850	23	1,8225
		MRO 12 - 90S4	25,92	187	0,8	18,7	7	4850	33	1,8225
	53	MRO 22 - 80C4	26,42	190	1,7	22	11	5450	23	3,0234
		MRO 22 - 90S4	26,42	190	1,7	22,7	11	5450	33	3,0234
	52	MRO 32 - 80C4	27,01	195	2,6	26	15	8400	23	3,1801
		MRO 32 - 90S4	27,01	195	2,6	26,7	15	8400	33	3,1801
	51	MRO 12 - 80C4	27,64	199	1	18	7	4550	23	1,772
		MRO 12 - 90S4	27,64	199	1	18,7	7	4550	33	1,772
	45	MRO 12 - 80C4	31,45	227	0,9	18	7	4800	23	1,7418
		MRO 12 - 90S4	31,45	227	0,9	18,7	7	4800	33	1,7418
	43	MRO 32 - 80C4	32,3	233	2,1	26	15	9050	23	3,058
		MRO 32 - 90S4	32,3	233	2,1	26,7	15	9050	33	3,058
		MRO 22 - 80C4	32,3	233	1,4	22	11	5900	23	2,9572



MRO-2 - 1400 rpm
 Motoriduttore
 Geared motor
 Getriebemotor

P ₁ [kW]	n ₂ [rpm]	Tipo - Size - Größe	i _r	M ₂ [Nm]	FS	MRO [kg]	FRO [kg]	F _{r2} [N]	J _m × 10 ⁻³	J ₁ × 10 ⁻⁴
1,1	43	MRO 22 - 90S4	32,3	233	1,4	22,7	11	5900	33	2,9572
	42	MRO 22 - 80C4	33,64	242	1,4	22	11	6100	23	2,9816
		MRO 22 - 90S4	33,64	242	1,4	22,7	11	6100	33	2,9816
	38	MRO 32 - 80C4	36,69	264	1,9	26	15	9950	23	3,0718
		MRO 32 - 90S4	36,69	264	1,9	26,7	15	9950	33	3,0718
		MRO 22 - 80C4	37,06	267	1,2	22	11	6350	23	2,9425
		MRO 22 - 90S4	37,06	267	1,2	22,7	11	6350	33	2,9425
	37	MRO 32 - 80C4	37,89	273	1,8	26	15	9800	23	3,0222
		MRO 32 - 90S4	37,89	273	1,8	26,7	15	9800	33	3,0222
	31	MRO 32 - 80C4	45,05	325	1,5	26	15	9800	23	2,9882
		MRO 32 - 90S4	45,05	325	1,5	26,7	15	9800	33	2,9882
	30	MRO 22 - 80C4	47,18	340	1	22	11	6400	23	2,9213
		MRO 22 - 90S4	47,18	340	1	22,7	11	6400	33	2,9213
	27	MRO 32 - 80C4	51,46	371	1,3	26	15	9800	23	2,9671
		MRO 32 - 90S4	51,46	371	1,3	26,7	15	9800	33	2,9671
		MRO 22 - 80C4	51,93	374	0,8	22	11	6450	23	2,9144
		MRO 22 - 90S4	51,93	374	0,8	22,7	11	6450	33	2,9144
	1,5	278	MRO 12 - 90L4	5,03	49	2,7	21,4	7	2300	40
270		MRO 32 - 90L4	5,18	51	>3	29,4	15	4800	40	9,0749
		MRO 22 - 90L4	5,18	51	>3	25,4	11	3150	40	5,8944
		MRO 02 - 90L4	5,18	51	2,1	18,8	4,4	1700	40	1,214
197		MRO 12 - 90L4	7,09	70	2,5	21,4	7	2450	40	2,6978
195		MRO 02 - 90L4	7,19	71	1,6	18,8	4,4	2000	40	1,015
192		MRO 32 - 90L4	7,28	72	>3	29,4	15	5650	40	6,7749
		MRO 22 - 90L4	7,28	72	>3	25,4	11	3200	40	4,792
167		MRO 22 - 90L4	8,36	82	>3	25,4	11	3450	40	4,5033
164		MRO 32 - 90L4	8,54	84	>3	29,4	15	6000	40	6,07
163		MRO 02 - 90L4	8,58	84	1,3	18,8	4,4	2200	40	0,944
160		MRO 12 - 90L4	8,74	86	2,1	21,4	7	2700	40	2,5046
132		MRO 12 - 90L4	10,57	104	1,9	21,4	7	2700	40	2,0326
129		MRO 32 - 90L4	10,88	107	>3	29,4	15	6000	40	4,2665
		MRO 22 - 90L4	10,88	107	2,5	25,4	11	3700	40	3,5463
		MRO 02 - 90L4	10,88	107	1,1	18,8	4,4	2300	40	0,639
121		MRO 32 - 90L4	11,6	114	>3	29,4	15	6400	40	4,9874
120		MRO 22 - 90L4	11,71	115	2,3	25,4	11	4050	40	3,9507
113		MRO 12 - 90L4	12,34	121	1,2	21,4	7	3550	40	2,2731
94		MRO 12 - 90L4	14,9	146	1,4	21,4	7	3350	40	1,9187
91		MRO 32 - 90L4	15,31	150	>3	29,4	15	6450	40	3,7457
		MRO 22 - 90L4	15,31	150	2,2	25,4	11	4100	40	3,2966
88		MRO 12 - 90L4	15,91	156	1,1	21,4	7	3650	40	1,8416
86		MRO 32 - 90L4	16,36	161	3	29,4	15	6500	40	3,4806
		MRO 22 - 90L4	16,36	161	2,1	25,4	11	4100	40	3,1625
80		MRO 22 - 90L4	17,56	173	1,9	25,4	11	4450	40	3,2313
78		MRO 32 - 90L4	17,95	176	2,8	29,4	15	6900	40	3,586
76		MRO 12 - 90L4	18,37	181	1,1	21,4	7	3750	40	1,8749
66		MRO 32 - 90L4	21,35	210	2,4	29,4	15	7550	40	3,4347
64		MRO 12 - 90L4	21,75	214	0,8	21,4	7	4350	40	1,8457
63		MRO 22 - 90L4	22,35	220	1,5	25,4	11	5000	40	3,1366
62		MRO 12 - 90L4	22,42	220	0,9	21,4	7	4100	40	1,7913
61		MRO 32 - 90L4	23,03	226	2,2	29,4	15	7700	40	3,2506



MRO-2 - 1400 rpm
 Motoriduttore
 Geared motor
 Getriebemotor

P ₁ [kW]	n ₂ [rpm]	Tipo - Size - Größe	i _r	M ₂ [Nm]	FS	MRO [kg]	FRO [kg]	F _{r2} [N]	J _m × 10 ⁻⁴	J ₁ × 10 ⁻⁴
1,5	61	MRO 22 - 90L4	23,03	226	1,5	25,4	11	5000	40	3,0523
	57	MRO 32 - 90L4	24,39	240	2,1	29,4	15	8300	40	3,3409
		MRO 22 - 90L4	24,61	242	1,2	25,4	11	5500	40	3,1062
	53	MRO 22 - 90L4	26,42	260	1,3	25,4	11	5450	40	3,0234
	52	MRO 32 - 90L4	27,01	265	1,9	29,4	15	8400	40	3,1801
	43	MRO 32 - 90L4	32,3	317	1,6	29,4	15	9050	40	3,058
		MRO 22 - 90L4	32,3	317	1	25,4	11	5900	40	2,9572
	42	MRO 22 - 90L4	33,64	331	1	25,4	11	6100	40	2,9816
	38	MRO 32 - 90L4	36,69	361	1,4	29,4	15	9950	40	3,0718
		MRO 22 - 90L4	37,06	364	0,9	25,4	11	6350	40	2,9425
	37	MRO 32 - 90L4	37,89	372	1,3	29,4	15	9800	40	3,0222
	31	MRO 32 - 90L4	45,05	443	1,1	29,4	15	9800	40	2,9882
27	MRO 32 - 90L4	51,46	506	1	29,4	15	9800	40	2,9671	
2,2	278	MRO 12 - 90LC4	5,03	72	1,9	24,6	7	2300	60	3,2008
		MRO 12 - 100A4	5,03	72	1,9	26,2	7	2300	75	3,2008
	270	MRO 32 - 90LC4	5,18	75	>3	32,6	15	4800	60	9,0749
		MRO 32 - 100A4	5,18	75	>3	34,2	15	4800	75	9,0749
		MRO 22 - 90LC4	5,18	75	2,4	28,6	11	3150	60	5,8944
		MRO 22 - 100A4	5,18	75	2,4	30,2	11	3150	75	5,8944
		MRO 02 - 90LC4	5,18	75	1,4	22	4,4	1700	60	1,214
		197	MRO 12 - 90LC4	7,09	102	1,7	24,6	7	2450	60
		MRO 12 - 100A4	7,09	102	1,7	26,2	7	2450	75	2,6978
	195	MRO 02 - 90LC4	7,19	104	1,1	22	4,4	2000	60	1,015
	192	MRO 32 - 90LC4	7,28	105	2,7	32,6	15	5650	60	6,7749
		MRO 32 - 100A4	7,28	105	2,7	34,2	15	5650	75	6,7749
		MRO 22 - 90LC4	7,28	105	2,4	28,6	11	3200	60	4,792
		MRO 22 - 100A4	7,28	105	2,4	30,2	11	3200	75	4,792
	167	MRO 22 - 90LC4	8,36	120	2,2	28,6	11	3450	60	4,5033
		MRO 22 - 100A4	8,36	120	2,2	30,2	11	3450	75	4,5033
	164	MRO 32 - 90LC4	8,54	123	2,4	32,6	15	6000	60	6,07
		MRO 32 - 100A4	8,54	123	2,4	34,2	15	6000	75	6,07
	163	MRO 02 - 90LC4	8,58	124	0,9	22	4,4	2200	60	0,944
	160	MRO 12 - 90LC4	8,74	126	1,4	24,6	7	2700	60	2,5046
		MRO 12 - 100A4	8,74	126	1,4	26,2	7	2700	75	2,5046
	132	MRO 12 - 90LC4	10,57	152	1,3	24,6	7	2700	60	2,0326
		MRO 12 - 100A4	10,57	152	1,3	26,2	7	2700	75	2,0326
	129	MRO 32 - 90LC4	10,88	157	2,4	32,6	15	6000	60	4,2665
		MRO 32 - 100A4	10,88	157	2,4	34,2	15	6000	75	4,2665
		MRO 22 - 90LC4	10,88	157	1,7	28,6	11	3700	60	3,5463
		MRO 22 - 100A4	10,88	157	1,7	30,2	11	3700	75	3,5463
	121	MRO 32 - 90LC4	11,6	167	2,4	32,6	15	6400	60	4,9874
		MRO 32 - 100A4	11,6	167	2,4	34,2	15	6400	75	4,9874
	120	MRO 22 - 90LC4	11,71	169	1,6	28,6	11	4050	60	3,9507
		MRO 22 - 100A4	11,71	169	1,6	30,2	11	4050	75	3,9507
	113	MRO 12 - 90LC4	12,34	178	0,8	24,6	7	3550	60	2,2731
		MRO 12 - 100A4	12,34	178	0,8	26,2	7	3550	75	2,2731
	94	MRO 12 - 90LC4	14,9	215	0,9	24,6	7	3350	60	1,9187
		MRO 12 - 100A4	14,9	215	0,9	26,2	7	3350	75	1,9187
	91	MRO 32 - 90LC4	15,31	221	2,2	32,6	15	6450	60	3,7457
		MRO 32 - 100A4	15,31	221	2,2	34,2	15	6450	75	3,7457



MRO-2 - 1400 rpm
 Motoriduttore
 Geared motor
 Getriebemotor

P ₁ [kW]	n ₂ [rpm]	Tipo - Size - Größe	i _r	M ₂ [Nm]	FS	MRO [kg]	FRO [kg]	F _{r2} [N]	J _m × 10 ⁻³	J ₁ × 10 ⁻⁴
2,2	91	MRO 22 - 90LC4	15,31	221	1,5	28,6	11	4100	60	3,2966
		MRO 22 - 100A4	15,31	221	1,5	30,2	11	4100	75	3,2966
	86	MRO 32 - 90LC4	16,36	236	2	32,6	15	6500	60	3,4806
		MRO 32 - 100A4	16,36	236	2	34,2	15	6500	75	3,4806
		MRO 22 - 90LC4	16,36	236	1,4	28,6	11	4100	60	3,1625
		MRO 22 - 100A4	16,36	236	1,4	30,2	11	4100	75	3,1625
	80	MRO 22 - 90LC4	17,56	253	1,3	28,6	11	4450	60	3,2313
		MRO 22 - 100A4	17,56	253	1,3	30,2	11	4450	75	3,2313
	78	MRO 32 - 90LC4	17,95	259	1,9	32,6	15	6900	60	3,586
		MRO 32 - 100A4	17,95	259	1,9	34,2	15	6900	75	3,586
	66	MRO 32 - 90LC4	21,35	308	1,6	32,6	15	7550	60	3,4347
		MRO 32 - 100A4	21,35	308	1,6	34,2	15	7550	75	3,4347
	63	MRO 22 - 90LC4	22,35	322	1	28,6	11	5000	60	3,1366
		MRO 22 - 100A4	22,35	322	1	30,2	11	5000	75	3,1366
	61	MRO 32 - 90LC4	23,03	332	1,5	32,6	15	7700	60	3,2506
		MRO 32 - 100A4	23,03	332	1,5	34,2	15	7700	75	3,2506
		MRO 22 - 90LC4	23,03	332	1	28,6	11	5000	60	3,0523
		MRO 22 - 100A4	23,03	332	1	30,2	11	5000	75	3,0523
	57	MRO 32 - 90LC4	24,39	352	1,4	32,6	15	8300	60	3,3409
		MRO 32 - 100A4	24,39	352	1,4	34,2	15	8300	75	3,3409
		MRO 22 - 90LC4	24,61	355	0,8	28,6	11	5500	60	3,1062
		MRO 22 - 100A4	24,61	355	0,8	30,2	11	5500	75	3,1062
	53	MRO 22 - 90LC4	26,42	381	0,9	28,6	11	5450	60	3,0234
		MRO 22 - 100A4	26,42	381	0,9	30,2	11	5450	75	3,0234
	52	MRO 32 - 90LC4	27,01	389	1,3	32,6	15	8400	60	3,1801
		MRO 32 - 100A4	27,01	389	1,3	34,2	15	8400	75	3,1801
	43	MRO 32 - 90LC4	32,3	466	1,1	32,6	15	9050	60	3,058
		MRO 32 - 100A4	32,3	466	1,1	34,2	15	9050	75	3,058
38	MRO 32 - 90LC4	36,69	529	0,9	32,6	15	9950	60	3,0718	
	MRO 32 - 100A4	36,69	529	0,9	34,2	15	9950	75	3,0718	
37	MRO 32 - 90LC4	37,89	546	0,9	32,6	15	9800	60	3,0222	
	MRO 32 - 100A4	37,89	546	0,9	34,2	15	9800	75	3,0222	
3	278	MRO 12 - 100B4	5,03	99	1,4	29,9	7	2300	85	3,2008
	270	MRO 32 - 100B4	5,18	102	2,7	37,9	15	4800	85	9,0749
		MRO 22 - 100B4	5,18	102	1,8	33,9	11	3150	85	5,8944
	197	MRO 12 - 100B4	7,09	139	1,3	29,9	7	2450	85	2,6978
	192	MRO 32 - 100B4	7,28	143	2	37,9	15	5650	85	6,7749
		MRO 22 - 100B4	7,28	143	1,8	33,9	11	3200	85	4,792
	167	MRO 22 - 100B4	8,36	164	1,6	33,9	11	3450	85	4,5033
	164	MRO 32 - 100B4	8,54	168	1,8	37,9	15	6000	85	6,07
	160	MRO 12 - 100B4	8,74	172	1	29,9	7	2700	85	2,5046
	132	MRO 12 - 100B4	10,57	208	1	29,9	7	2700	85	2,0326
	129	MRO 32 - 100B4	10,88	214	1,7	37,9	15	6000	85	4,2665
		MRO 22 - 100B4	10,88	214	1,3	33,9	11	3700	85	3,5463
	121	MRO 32 - 100B4	11,6	228	1,8	37,9	15	6400	85	4,9874
	120	MRO 22 - 100B4	11,71	230	1,2	33,9	11	4050	85	3,9507
	91	MRO 32 - 100B4	15,31	301	1,6	37,9	15	6450	85	3,7457
		MRO 22 - 100B4	15,31	301	1,1	33,9	11	4100	85	3,2966
	86	MRO 32 - 100B4	16,36	322	1,5	37,9	15	6500	85	3,4806
		MRO 22 - 100B4	16,36	322	1	33,9	11	4100	85	3,1625



MRO-2 - 1400 rpm
 Motoriduttore
 Geared motor
 Getriebemotor

P ₁ [kW]	n ₂ [rpm]	Tipo - Size - Größe	i _r	M ₂ [Nm]	FS	MRO [kg]	FRO [kg]	F _{r2} [N]	J _m × 10 ⁻⁴	J ₁ × 10 ⁻⁴
3	80	MRO 22 - 100B4	17,56	345	1	33,9	11	4450	85	3,2313
	78	MRO 32 - 100B4	17,95	353	1,4	37,9	15	6900	85	3,586
	66	MRO 32 - 100B4	21,35	420	1,2	37,9	15	7550	85	3,4347
	61	MRO 32 - 100B4	23,03	453	1,1	37,9	15	7700	85	3,2506
	57	MRO 32 - 100B4	24,39	479	1	37,9	15	8300	85	3,3409
	52	MRO 32 - 100B4	27,01	531	0,9	37,9	15	8400	85	3,1801
	43	MRO 32 - 100B4	32,3	635	0,8	37,9	15	9050	85	3,058
4	278	MRO 12 - 112A4	5,03	132	1	36	7	2300	130	3,2008
	270	MRO 32 - 112A4	5,18	136	2	44	15	4800	130	9,0749
		MRO 22 - 112A4	5,18	136	1,3	40	11	3150	130	5,8944
	197	MRO 12 - 112A4	7,09	186	0,9	36	7	2450	130	2,6978
	192	MRO 32 - 112A4	7,28	191	1,5	44	15	5650	130	6,7749
		MRO 22 - 112A4	7,28	191	1,3	40	11	3200	130	4,792
	167	MRO 22 - 112A4	8,36	219	1,2	40	11	3450	130	4,5033
	164	MRO 32 - 112A4	8,54	224	1,3	44	15	6000	130	6,07
	160	MRO 12 - 112A4	8,74	229	0,8	36	7	2700	130	2,5046
	129	MRO 32 - 112A4	10,88	285	1,3	44	15	6000	130	4,2665
		MRO 22 - 112A4	10,88	285	0,9	40	11	3700	130	3,5463
	121	MRO 32 - 112A4	11,6	304	1,3	44	15	6400	130	4,9874
	120	MRO 22 - 112A4	11,71	307	0,9	40	11	4050	130	3,9507
	91	MRO 32 - 112A4	15,31	401	1,2	44	15	6450	130	3,7457
		MRO 22 - 112A4	15,31	401	0,8	40	11	4100	130	3,2966
	86	MRO 32 - 112A4	16,36	429	1,1	44	15	6500	130	3,4806
	78	MRO 32 - 112A4	17,95	470	1,1	44	15	6900	130	3,586
	66	MRO 32 - 112A4	21,35	559	0,9	44	15	7550	130	3,4347
	61	MRO 32 - 112A4	23,03	603	0,8	44	15	7700	130	3,2506
	57	MRO 32 - 112A4	24,39	639	0,8	44	15	8300	130	3,3409
5,5	270	MRO 32 - 112MC4	5,18	187	1,4	50,7	15	4800	160	9,0749
		MRO 32 - 132S4	5,18	187	1,4	54	15	4800	240	9,0749
		MRO 22 - 112MC4	5,18	187	1	46,7	11	3150	160	5,8944
	192	MRO 32 - 112MC4	7,28	262	1,1	50,7	15	5650	160	6,7749
		MRO 32 - 132S4	7,28	262	1,1	54	15	5650	240	6,7749
		MRO 22 - 112MC4	7,28	262	1	46,7	11	3200	160	4,792
	167	MRO 22 - 112MC4	8,36	301	0,9	46,7	11	3450	160	4,5033
	164	MRO 32 - 112MC4	8,54	308	1	50,7	15	6000	160	6,07
		MRO 32 - 132S4	8,54	308	1	54	15	6000	240	6,07
	129	MRO 32 - 112MC4	10,88	392	0,9	50,7	15	6000	160	4,2665
		MRO 32 - 132S4	10,88	392	0,9	54	15	6000	240	4,2665
	121	MRO 32 - 112MC4	11,6	418	1	50,7	15	6400	160	4,9874
		MRO 32 - 132S4	11,6	418	1	54	15	6400	240	4,9874
	91	MRO 32 - 112MC4	15,31	552	0,9	50,7	15	6450	160	3,7457
		MRO 32 - 132S4	15,31	552	0,9	54	15	6450	240	3,7457
	86	MRO 32 - 112MC4	16,36	589	0,8	50,7	15	6500	160	3,4806
	MRO 32 - 132S4	16,36	589	0,8	54	15	6500	240	3,4806	
7,5	270	MRO 32 - 132M4	5,18	254	1,1	63,5	15	4800	330	9,0749
	192	MRO 32 - 132M4	7,28	358	0,8	63,5	15	5650	330	6,7749
9,2	270	MRO 32 - 132ML4	5,18	312	0,9	71,5	15	4800	340	9,0749



MRO 02
FRO 02
RO 02

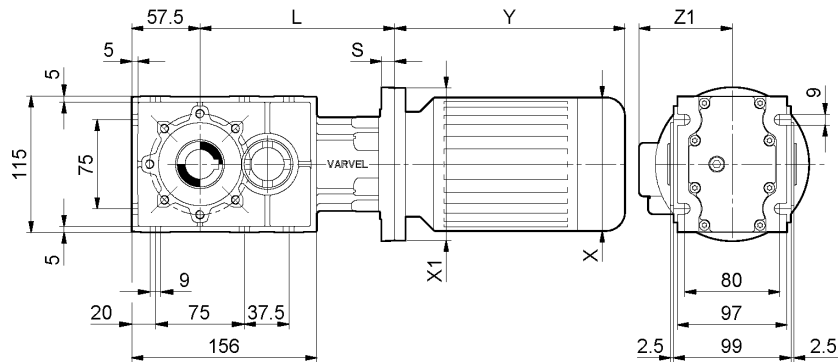

MRO02
FRO02

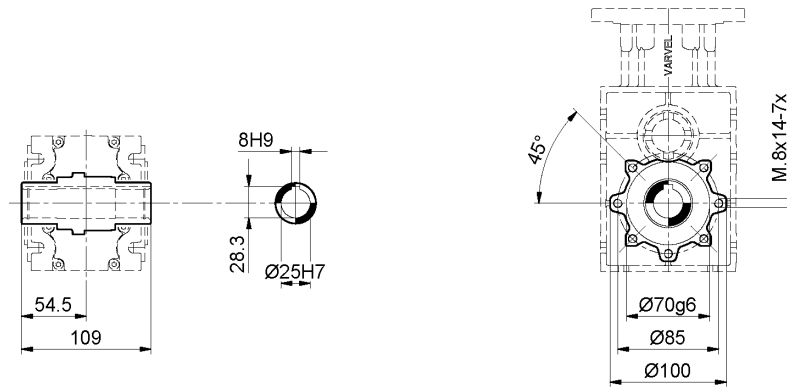

AC25

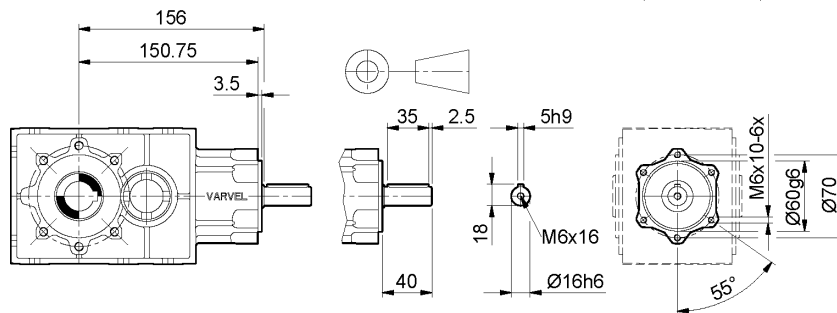

RO02

IEC	63	71	80	90 S	90 L	100	112
X / Y / Z1	123/185/11	140/215/12	159/238/13	176/255/149	176/280/14	195/309/16	219/328/17
X1 (B5) / S	140/17.5	160/15.5	200/15.5	200/15.5	200/15.5	250/16.7	250/16.7
X1 (B14) /	---	105/15.5	120/15.5	140/17.5	140/17.5	160/15.5	160/15.5
L (B5)	200.5	198.5	198.5	198.5	198.5	199.7	199.7
L (B14)	---	198.5	200.5	200.5	200.5	198.5	198.5

Dimensioni e pesi non impegnativi

Not binding dimensions and weights

unverbindliche Abmessungen u. Gewichte

MRO/FRO/RO 02

Alberi uscita
Output shafts
Ausgangswellen

AC

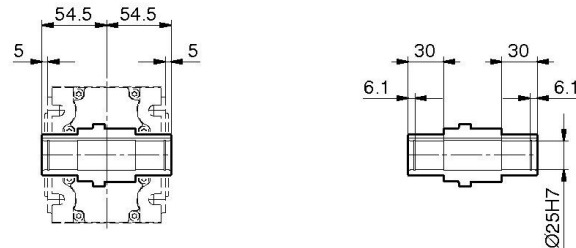

AS

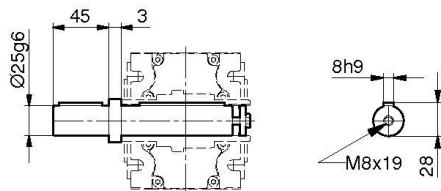

AD

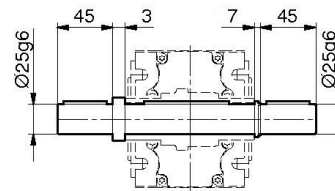

***ACC**

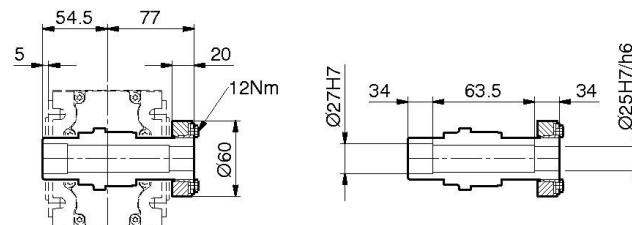

***ACS**

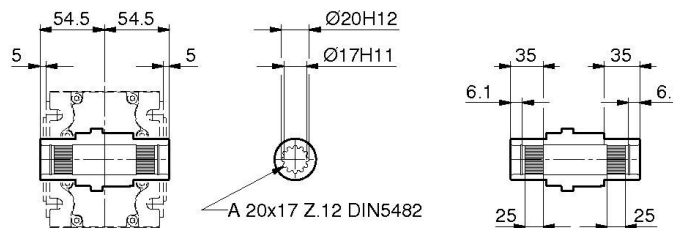

* - Versioni ACC e ACS a richiesta
Dimensioni perno macchina: pagine 52-54

Dimensioni e pesi non impegnativi

* - ACC and ACS versions on demand
Machine shaft dimensions: pages 52-54

Not binding dimensions and weights

* - ACC u. ACS-Ausführungen: auf Anfrage
Maschinenwelle Abmessungen: 52-54

unverbindliche Abmessungen u. Gewichte



MRO/FRO/RO 02

Flange uscita
Output flanges
Ausgangsflansche

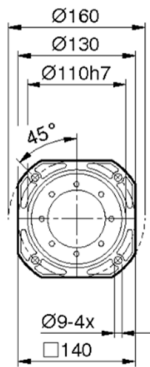
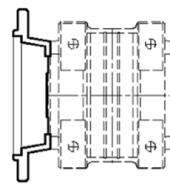
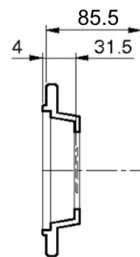
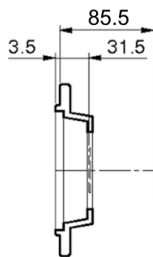
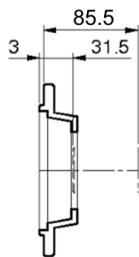

621.103.160

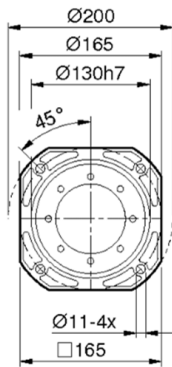

621.103.200

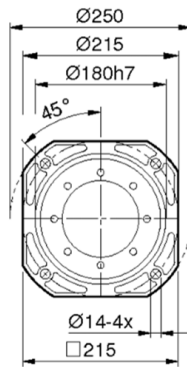

621.103.250

DFU

- Codice flangia
Dimensioni e pesi non impegnativi

- Flange Part No.
Not binding dimensions and weights

- Flanschteilenummer
unverbindliche Abmessungen u. Gewichte

MRO/FRO/RO 02

Bracci di reazione
Torque arms
Drehmomentstützen

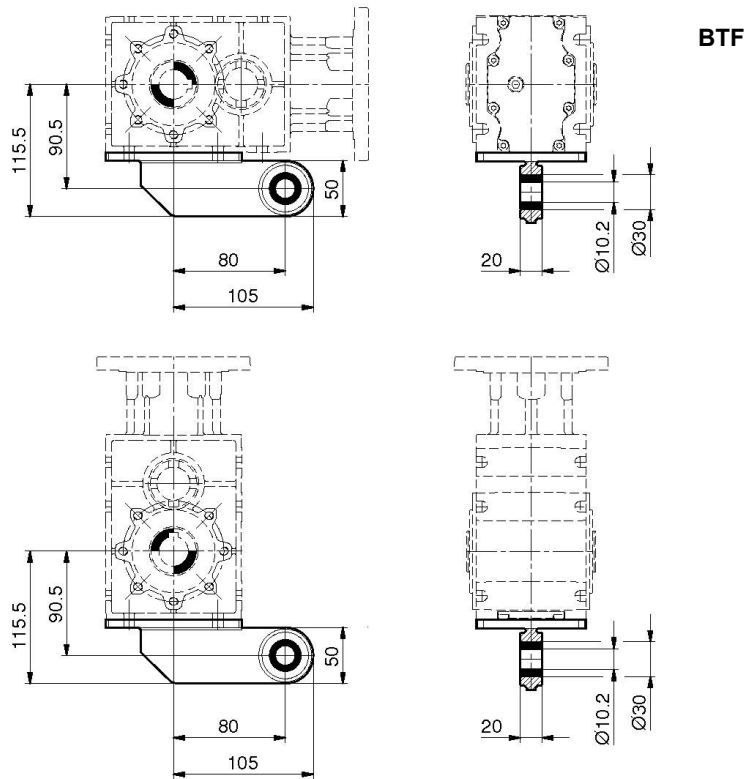
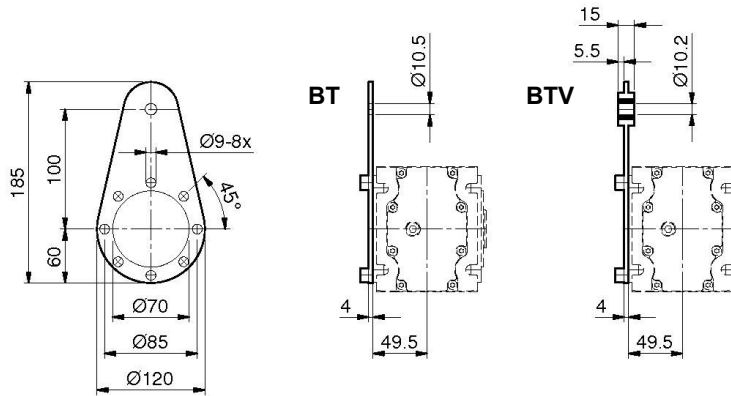

Dimensioni e pesi non impegnativi

Not binding dimensions and weights

unverbindliche Abmessungen u. Gewichte



MRO 12
FRO 12
RO 12

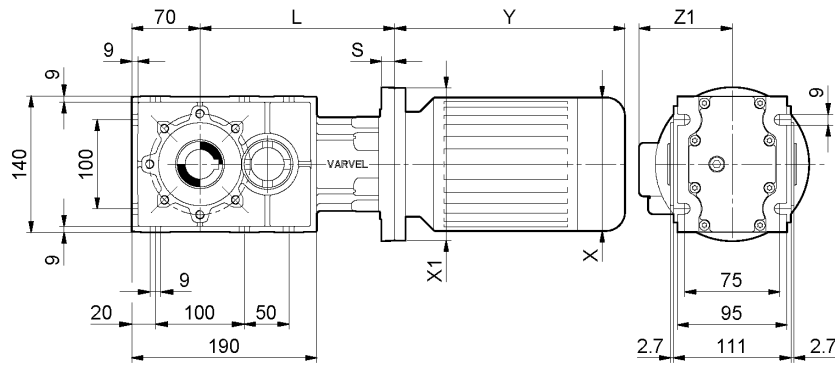

MRO12

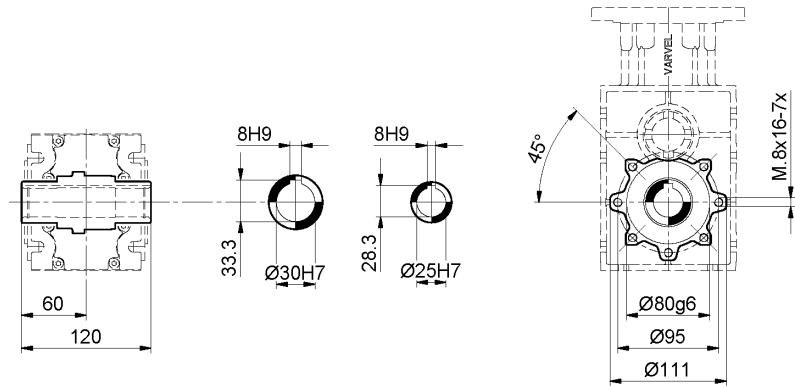

AC30
AC25

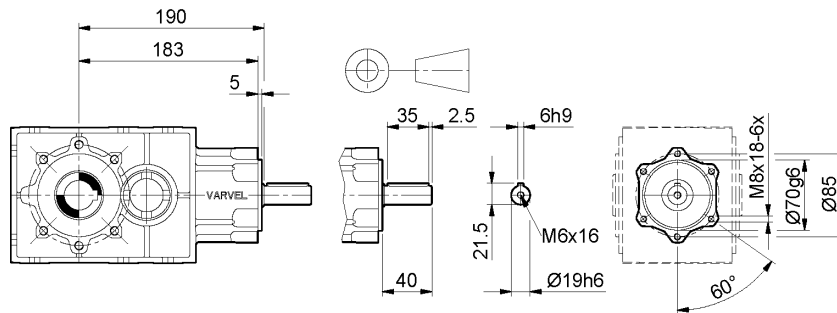

RO12

IEC	63	71	80	90 S	90 L	100	112
X / Y / Z1	123/185/11	140/215/12	159/238/13	176/255/149	176/280/14	195/309/16	219/328/17
X1 (B5) / S	140/17.5	160/15.5	200/15.5	200/15.5	200/15.5	250/16.7	250/16.7
X1 (B14) /	---	105/15.5	120/15.5	140/17.5	140/17.5	160/15.5	160/15.5
L (B5)	200.5	198.5	198.5	198.5	198.5	199.7	199.7
L (B14)	---	198.5	200.5	200.5	200.5	198.5	198.5

Dimensioni e pesi non impegnativi

Not binding dimensions and weights

unverbindliche Abmessungen u. Gewichte

MRO/FRO/RO 12

Alberi uscita
Output shafts
Ausgangswellen

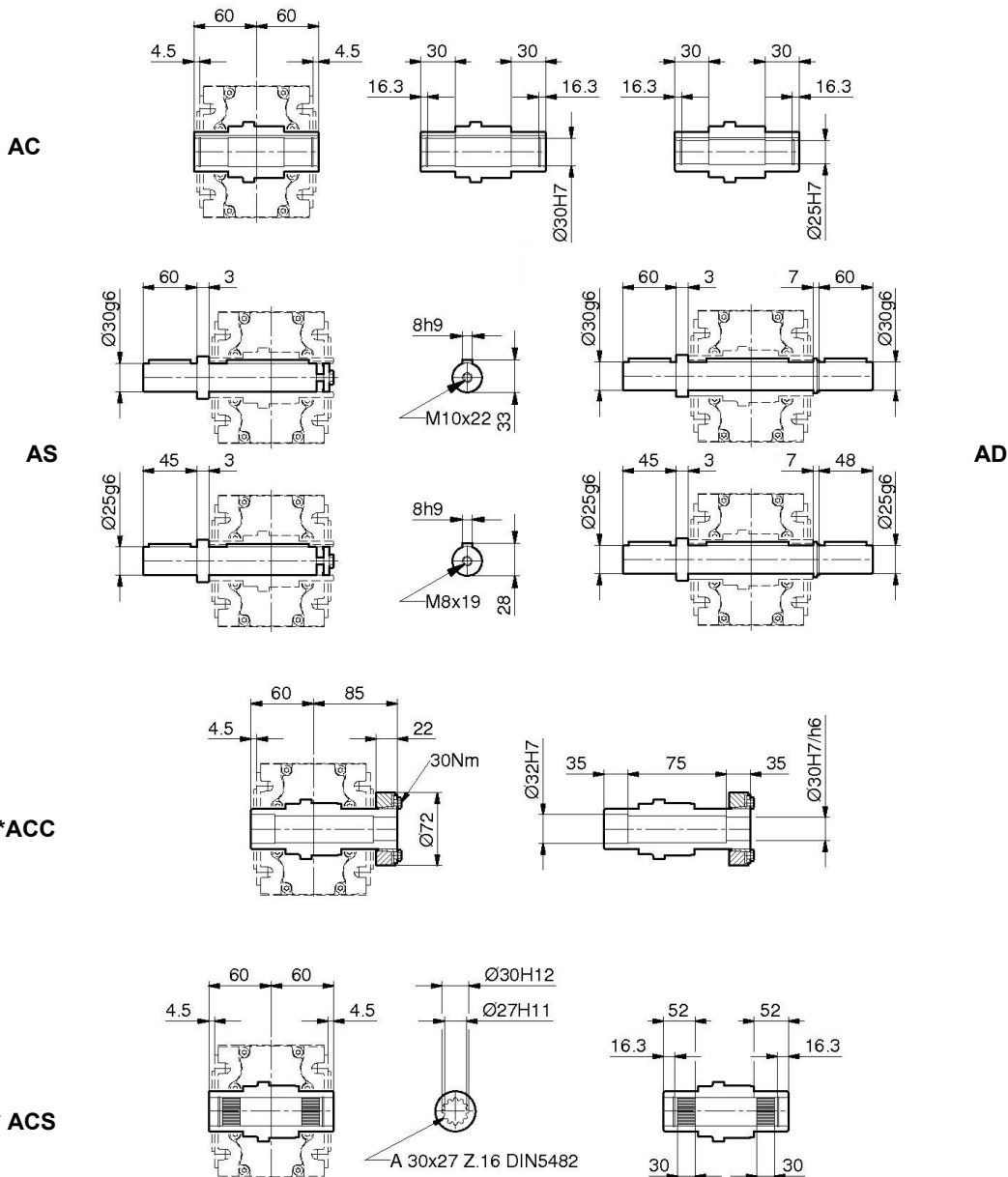

* - Versioni ACC e ACS a richiesta
Dimensioni perno macchina: pagine 52-54

Dimensioni e pesi non impegnativi

* - ACC and ACS versions on demand
Machine shaft dimensions: pages 52-54

Not binding dimensions and weights

* - ACC u. ACS-Ausführungen: auf Anfrage
Maschinenwelle Abmessungen: Seiten 52-54

unverbindliche Abmessungen u. Gewichte

MRO/FRO/RO 12

Flange uscita
Output flanges
Ausgangsflansche

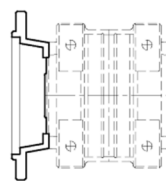
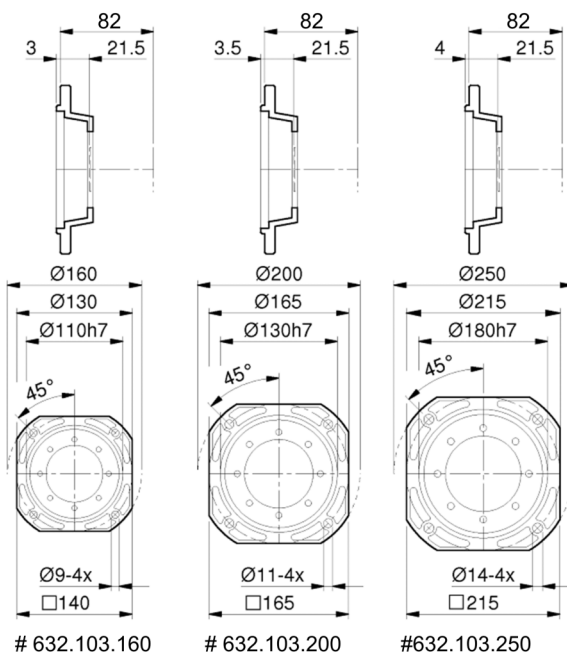

DFU-A

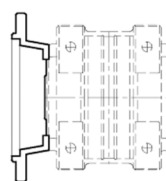
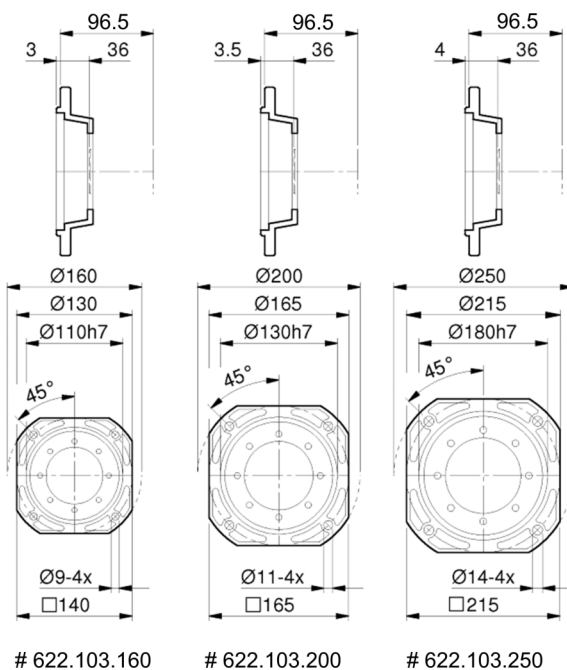

DFU-F

- Codice flangia
Dimensioni e pesi non impegnativi

- Flange Part No.
Not binding dimensions and weights

- Flanschteilenummer
unverbindliche Abmessungen u. Gewichte

MRO/FRO/RO 12

Bracci di reazione
Torque arms
Drehmomentstützen

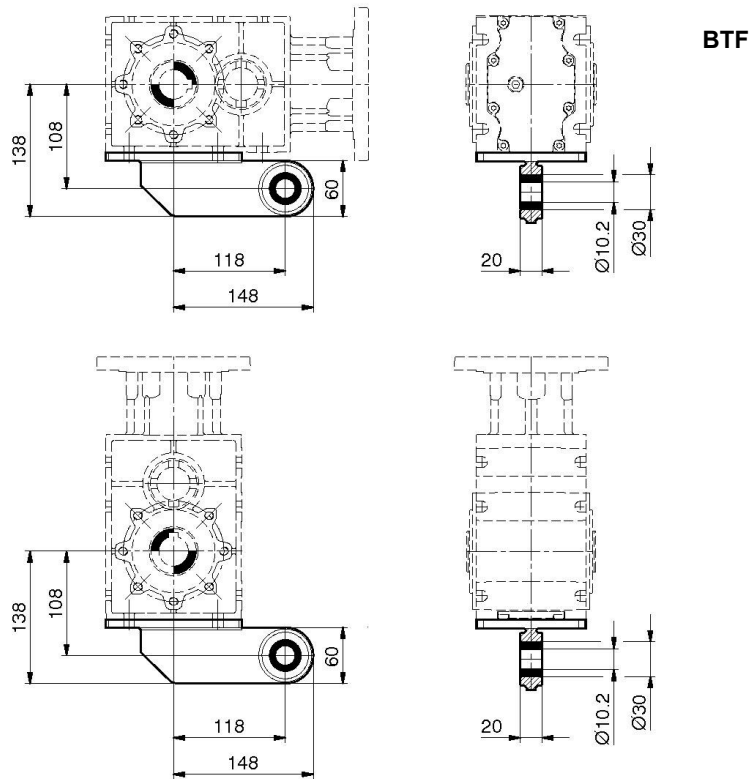
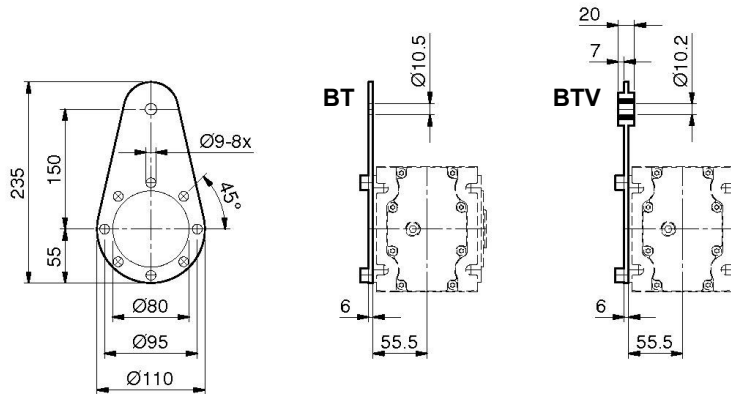

Dimensioni e pesi non impegnativi

Not binding dimensions and weights

unverbindliche Abmessungen u. Gewichte

**MRO 22
FRO 22
RO 22**

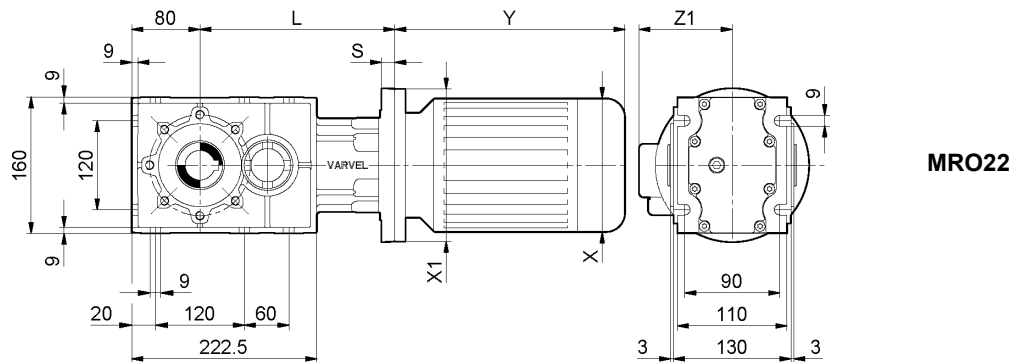

MRO22

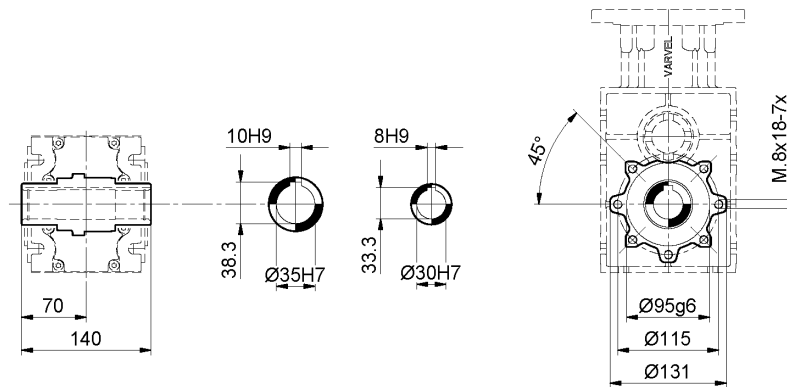

**AC35
AC30**

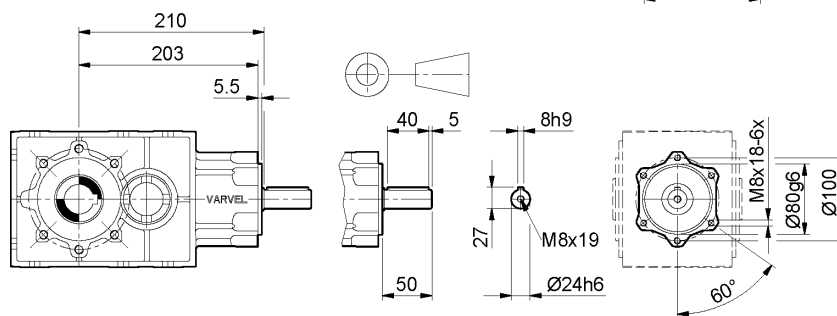

RO22

IEC	63	71	80	90 S	90 L	100	112
X / Y / Z1	123/185/11	140/215/12	159/238/13	176/255/149	176/280/14	195/309/16	219/328/17
X1 (B5) / S	140/18.5	160/15.5	200/15.5	200/15.5	200/15.5	250/16.7	250/16.7
X1 (B14) /	---	---	120/15.5	140/18.5	140/18.5	160/15.5	160/15.5
L (B5)	221.5	218.5	218.5	218.5	218.5	219.7	219.7
L (B14)	---	---	218.5	221.5	221.5	218.5	218.5

Dimensioni e pesi non impegnativi

Not binding dimensions and weights

unverbindliche Abmessungen u. Gewichte

MRO/FRO/RO 22

Alberi uscita
Output shafts
Ausgangswellen

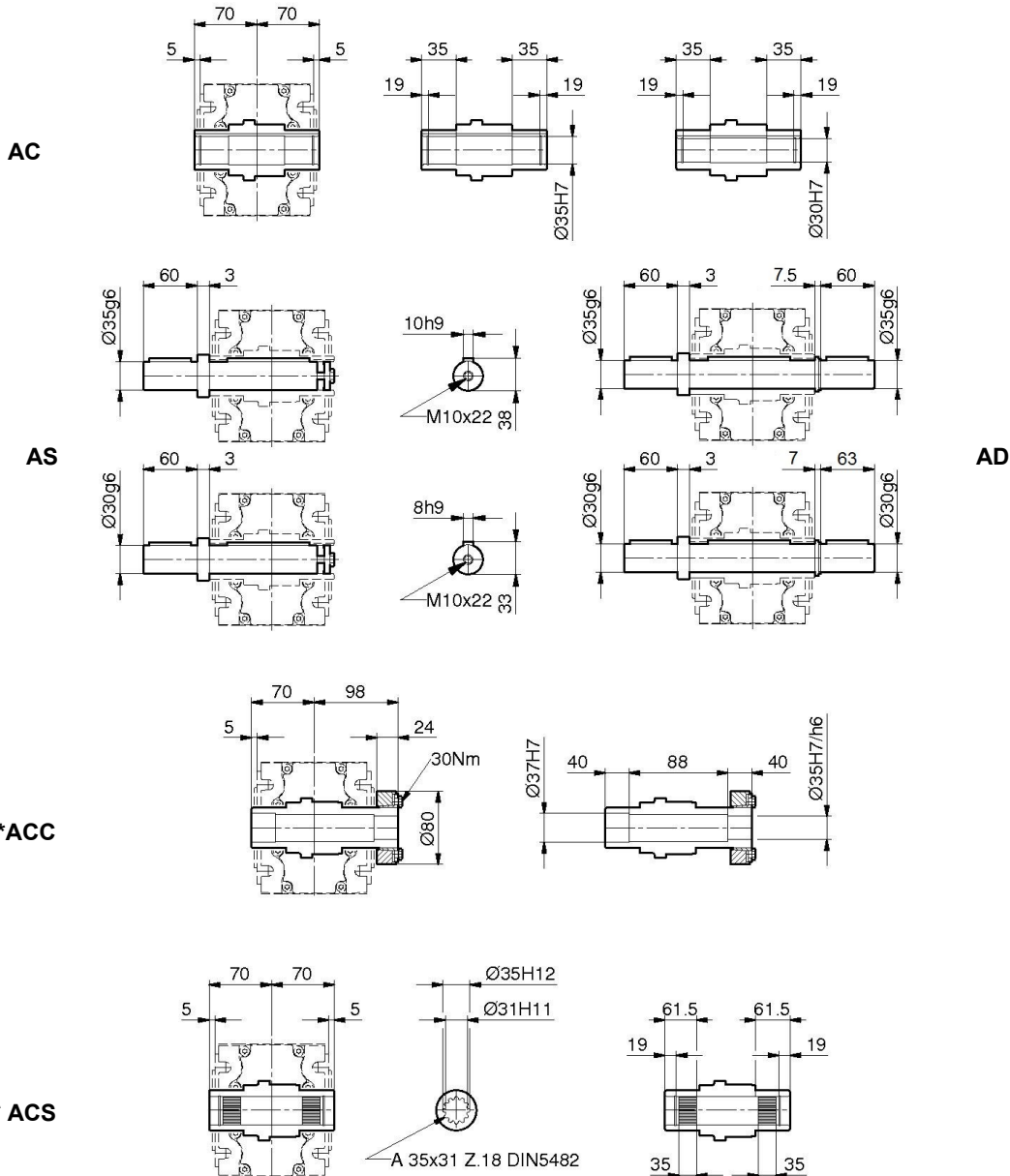

* - Versioni ACC e ACS a richiesta
Dimensioni perno macchina: pagine 52-54

Dimensioni e pesi non impegnativi

* - ACC and ACS versions on demand
Machine shaft dimensions: pages 52-54

Not binding dimensions and weights

* - ACC u. ACS-Ausführungen: auf Anfrage
Maschinenwelle Abmessungen: Seiten 52-54

unverbindliche Abmessungen u. Gewichte

MRO/FRO/RO 22

Flange uscita
Output flanges
Ausgangsflansche

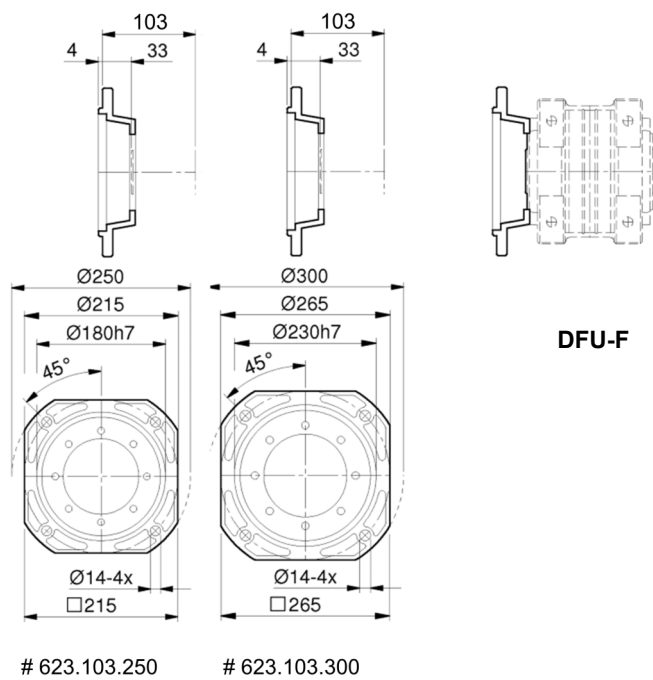
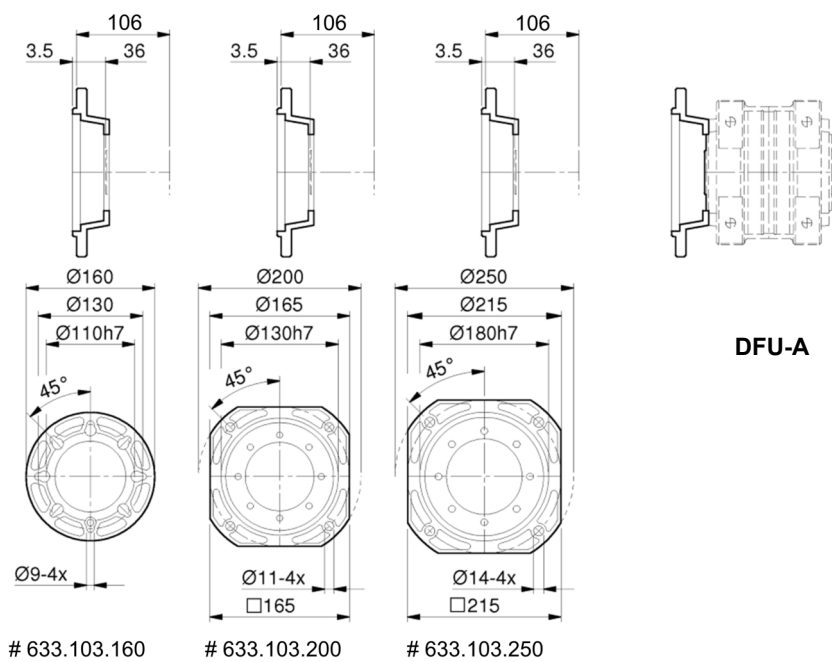

- Codice flangia
Dimensioni e pesi non impegnativi

- Flange Part No.
Not binding dimensions and weights

- Flanschteilenummer
unverbindliche Abmessungen u. Gewichte

MRO/FRO/RO 22

Bracci di reazione
Torque arms
Drehmomentstützen

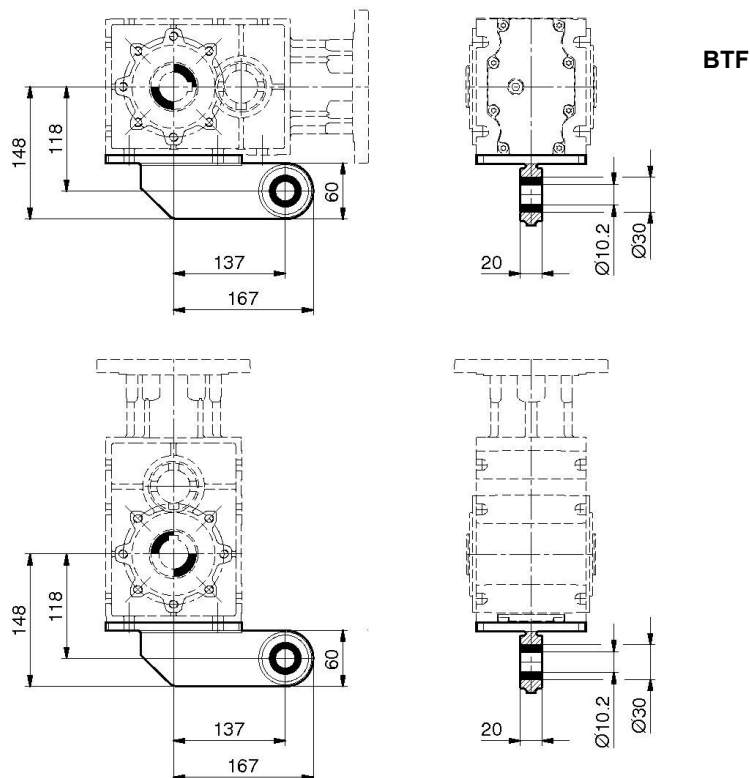
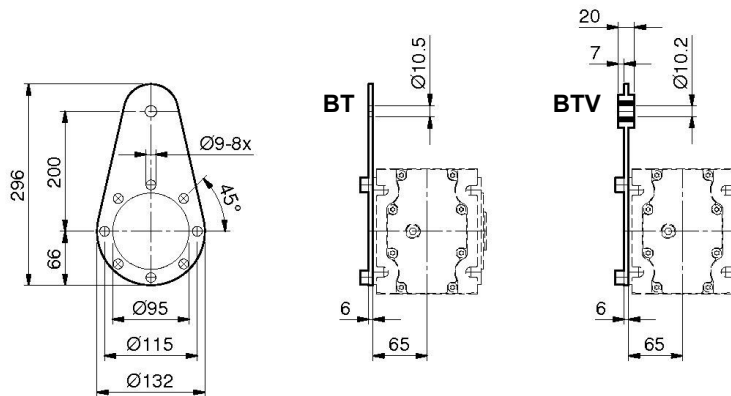

Dimensioni e pesi non impegnativi

Not binding dimensions and weights

unverbindliche Abmessungen u. Gewichte

MRO 32
FRO 32
RO 32

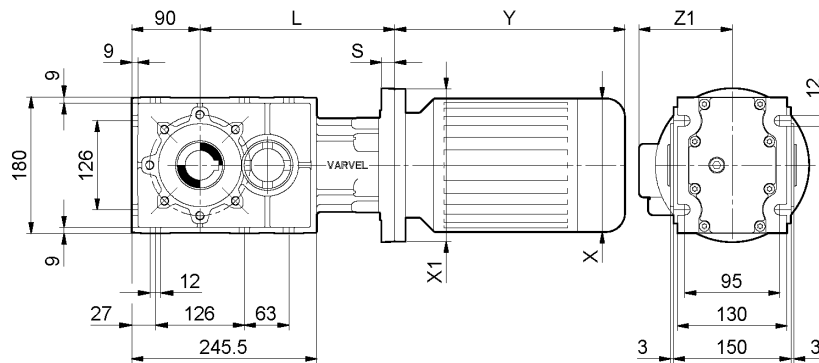

MRO32

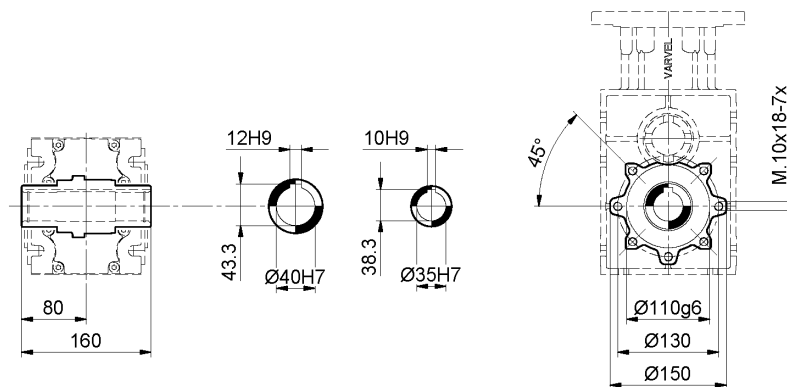

AC40
AC35

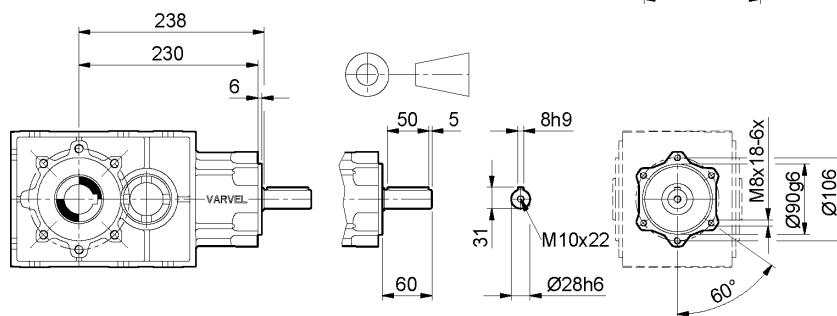

RO32

IEC	71	80	90 S	90 L	100	112	132 S (*)
X / Y / Z1	140/215/12	159/238/13	176/255/14	176/280/149	195/309/16	219/328/17	258/368/19
X1 (B5) / S	160/20	200/18	200/18	200/18	250/18.7	250/18.7	300/18
X1 (B14) /	---	---	---	---	160/20	160/20	200/18
L (B5)	250	248	248	248	248.7	248.7	298.5
L (B14)	---	---	---	---	250	250	298.5

Dimensioni e pesi non impegnativi

Not binding dimensions and weights

unverbindliche Abmessungen u. Gewichte

MRO/FRO/RO 32

Alberi uscita
Output shafts
Ausgangswellen

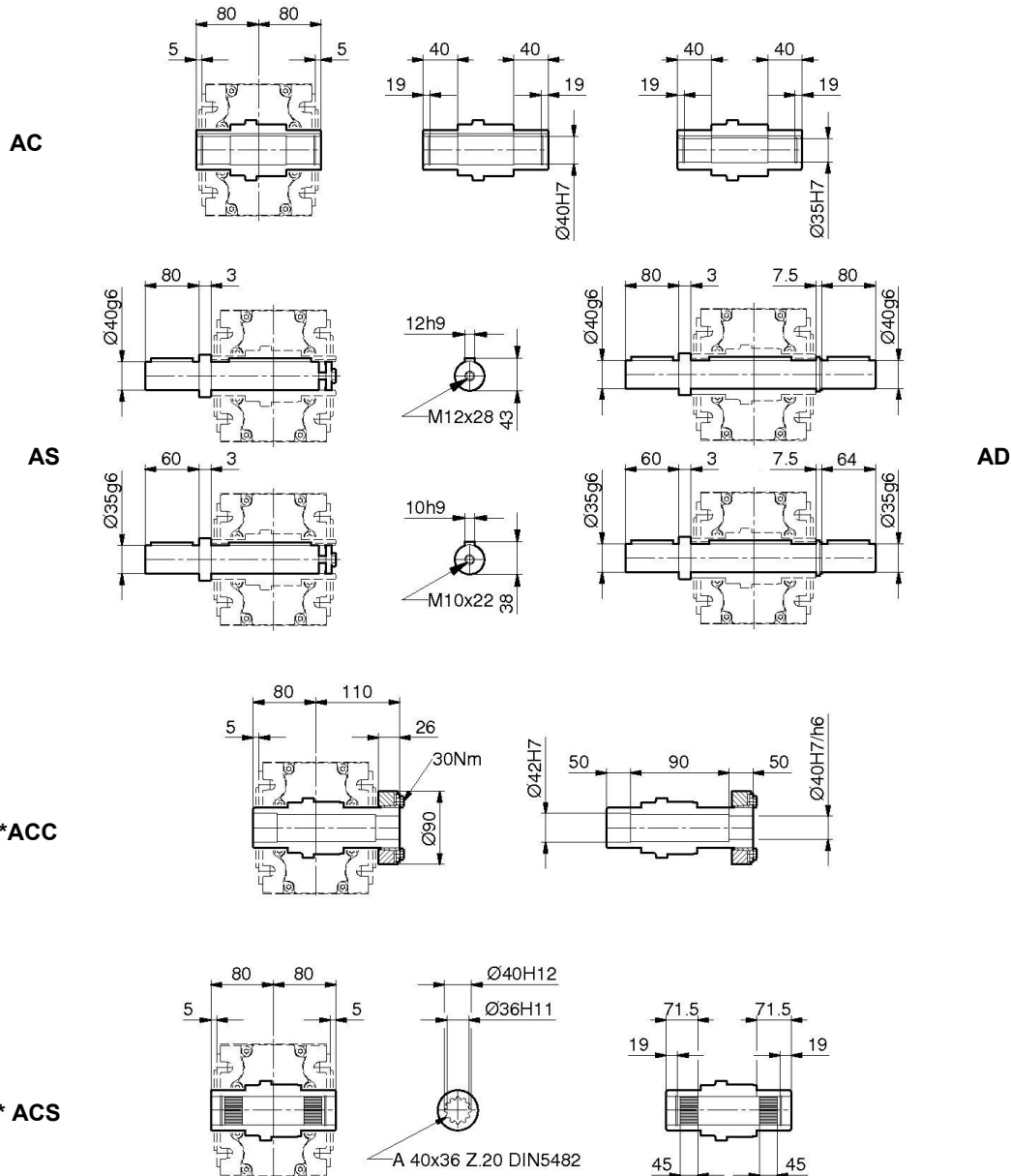

* - Versioni ACC e ACS a richiesta
Dimensioni perno macchina: pagine 52-54

Dimensioni e pesi non impegnativi

* - ACC and ACS versions on demand
Machine shaft dimensions: pages 52-54

Not binding dimensions and weights

* - ACC u. ACS-Ausführungen: auf Anfrage
Maschinenwelle Abmessungen: Seiten 52-54

unverbindliche Abmessungen u. Gewichte

MRO/FRO/RO 32

Flange uscita
Output flanges
Ausgangsflansche

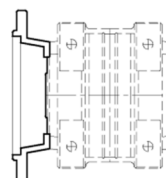
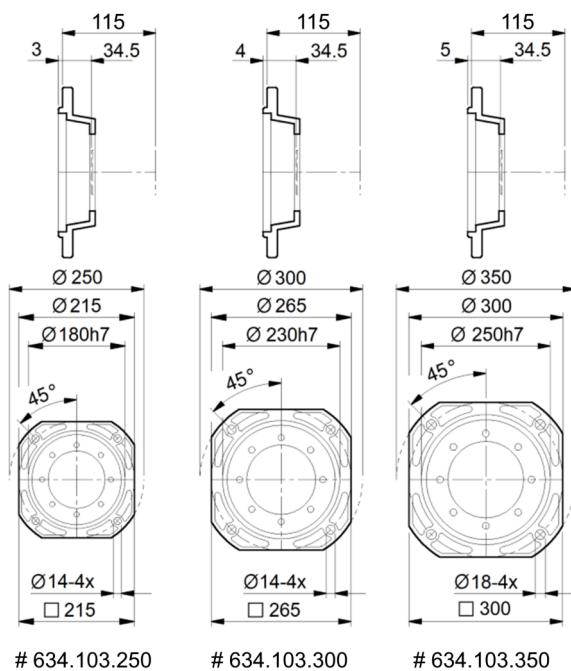

DFU-A

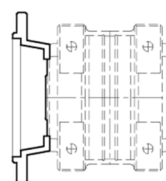
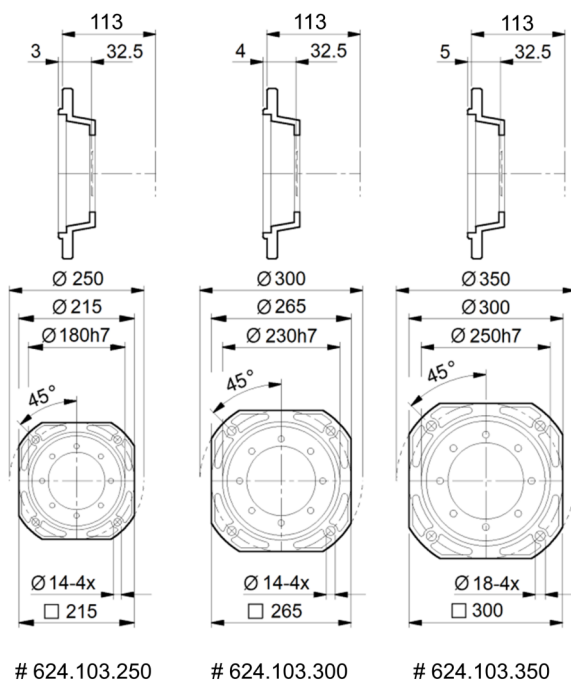

DFU-F

- Codice flangia
Dimensioni e pesi non impegnativi

- Flange Part No.
Not binding dimensions and weights

- Flanschteilenummer
unverbindliche Abmessungen u. Gewichte

MRO/FRO/RO 32

Bracci di reazione
Torque arms
Drehmomentstützen

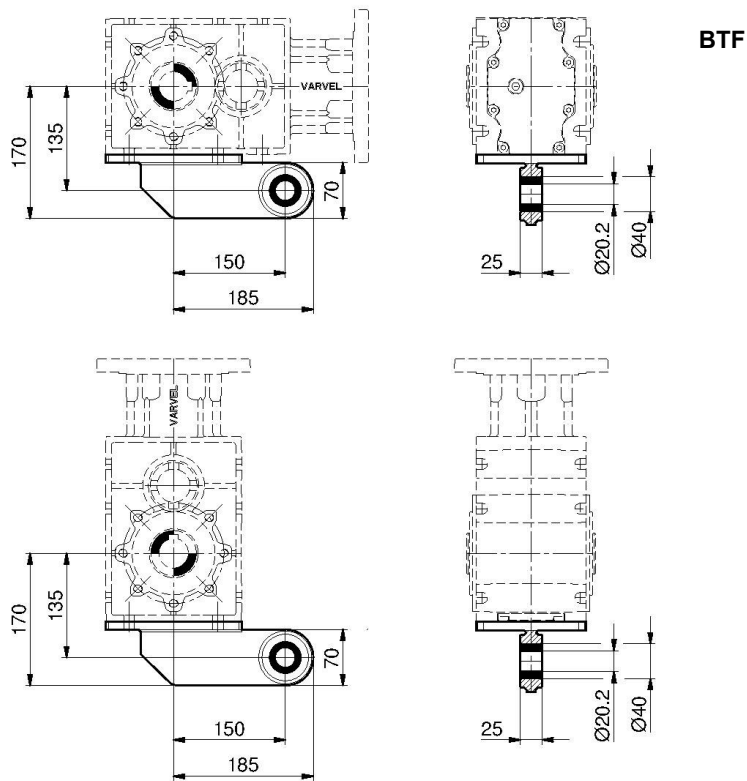
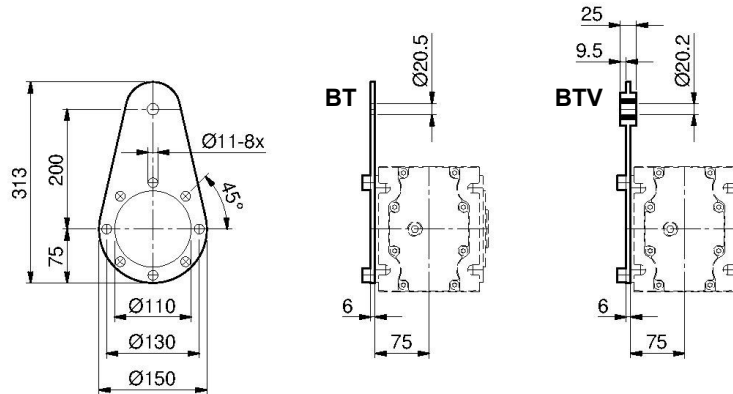

Dimensioni e pesi non impegnativi

Not binding dimensions and weights

unverbindliche Abmessungen u. Gewichte

AC

Albero uscita cavo (standard)
Hollow output shaft (standard)
Standard-Ausgangshohlwelle

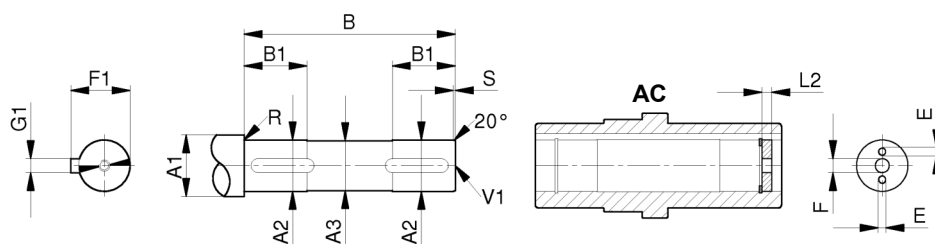

- Montaggio
Assembly
Montage

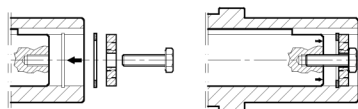

- Smontaggio
Disassembly
Demontage

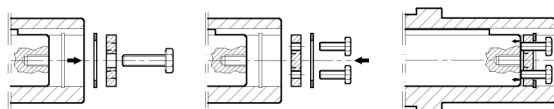

Typo Size Größe	A1	A2	A3	B	B1	E	F	F1	G1	L2	R	S	V1
RO02	35	25	24	98	35	M5	9	28	8	4.5	1	2	M8x19
RO12	40	30	29	98	35	M6	11	33	8	5.5	1	2	M10x22
	35	25	24	98	35	M5	9	28	8	4.5	1	2	M8x19
RO22	45	35	34	113.5	40	M8	11	38	10	7	1	2	M10x22
	40	30	29	113.5	40	M6	11	33	8	7	1	2	M10x22
RO32	50	40	38	133.5	45	M8	13	43	12	7	1	2	M12x28
	35	35	34	133.5	45	M8	11	38	10	7	1	2	M10x22

ACC

Albero uscita cavo con calettatore (a richiesta)
 Hollow output shaft with shrink-disk (on demand)
 Ausgangshohlwelle mit Schrumpfscheibe (auf Anfrage)

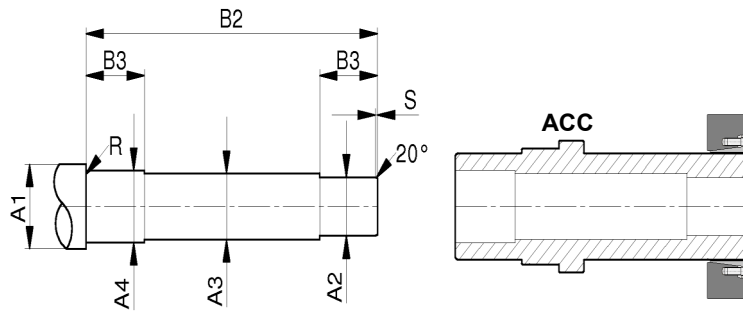

Tipo Size Größe	A1	A2	A3	A4	B2	B3	R	S
RO02	35	25	25	27	130.5	33	1	2
RO12	40	30	29	32	144	34	1	2
RO22	45	35	34	37	167	39	1	2
RO32	50	40	39	42	189	49	1	2

Il calettatore è basato sul principio del cono per creare un accoppiamento meccanico per interferenza senza chiavetta. Il serraggio assiale delle viti è convertito in pressione di contatto radiale fra albero e mozzo, causando lo stabile calettamento.

Montaggio

Pulire accuratamente le superfici di contatto dell'albero e del mozzo e applicare un leggero velo d'olio. Serrare le viti in modo graduale ed uniforme fino a raggiungere la coppia di serraggio. Non usare oli contenenti bisolfuro di molibdeno che originano notevole riduzione del coefficiente d'attrito. Durante il serraggio delle viti non avviene nessun spostamento assiale del mozzo rispetto all'albero.

Smontaggio

Allentare le viti con sequenza continua e graduale senza estrarre le viti dalle filettature. In caso di riutilizzo, applicare alle viti e superfici coniche un lubrificante in pasta per garantire un coefficiente d'attrito di 0.04. Coppie di serraggio, tolleranze e rugosità secondo le specifiche del costruttore.

The keying device is based on the wedge principle to create a mechanical coupling for interference without the need of a key. Stable shrinkage occurs due to the conversion of axial tightening of the screws into radial contact pressure between the shaft and the hub.

Assembly

Ensure that the contact surfaces of the shaft and hub are cleaned carefully and apply a light layer of oil. Gradually and evenly tighten the screws until the required tightness torque is reached. Avoid using oils that contain molybdenum disulfide, as it causes a significant drop in the coefficient of friction. The hub does not move axially with respect to the shaft during screw tightening.

Disassembly

Slowly loosen the screws without removing them from the threads. To ensure a coefficient of friction of 0.04, apply a lubricant paste to the screws and conical surfaces when reusing them. Tightening torques, tolerances, and roughness in accordance with manufacturer's specifications.

Die Schrumpfscheibe liegt dem versuchten Prinzip des Keiles zugrunde, um eine mechanische Kupplung zur Interferenz ohne Keilnut zu kreieren. Das axiale Anziehen der Schrauben wurde in radialem Anpressdruck zwischen Welle und Nabe umgesetzt, verursacht Stabilität der Schrumpfscheibe.

Montage

Sorgfältig die Kontaktflächen der Welle und der Nabe reinigen und ein wenig Öl aufbringen. Die Schrauben gradual und einheitlich anziehen bis zur Erzielung des Anzugsdrehmoment. Verwenden Sie keine Öle mit Molybdänsulfid, wegen erheblicher Reduzierung des Reibungskoeffizienten. Während des Anziehens der Schrauben erfolgt keine axiale Verschiebung der Nabe gegenüber der Welle.

Demontage

Lösen Sie die Schrauben kontinuierlich und schrittweise, ohne die Schrauben aus dem Gewinde zu entfernen. Im Falle der Wiederverwendung, tragen Sie auf den Schrauben und Kegelflächen eine Schmierpaste, um ein Reibungskoeffizient von 0,04 zu garantieren. Drehmomente, Toleranzen und Rauigkeit nach Angaben des Herstellers.

ACS

Albero uscita cavo scanalato (a richiesta)
 Splined hollow output shaft (on demand)
 Ausgangskeilhohlwelle (auf Anfrage)

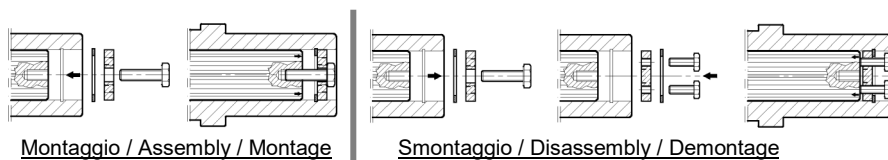
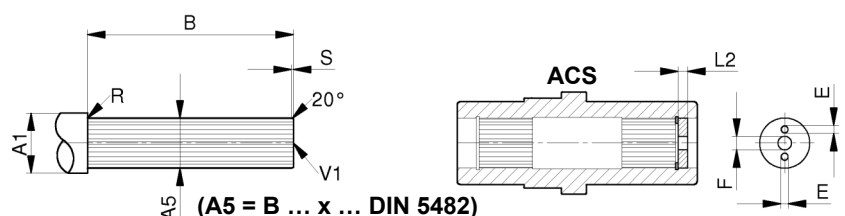

Tipo Size Größe	A1	A5	B	E	F	L2	R	S	V1
RO02	35	20x17	98	M4	9	4.5	1	2	M8x19
RO12	40	30x27	98	M6	11	5.5	1	2	M8x19
RO22	45	35x31	113.5	M8	11	7	1	2	M10x22
RO32	50	40x36	133.5	M8	13	7	1	2	M10x22

Gli alberi scanalati hanno denti che ingranano con corrispondenti scanalature di un pezzo accoppiante e gli trasferiscono la coppia mantenendo la corrispondenza angolare fra loro.

Alternativi al collegamento cava/chiavetta, gli scanalati forniscono maggior coppia e maggior durata alla fatica.

The splined shafts have teeth that mesh with the corresponding grooves of a coupler piece and transfer the torque, while maintaining the angular correspondence between them.

The grooves can offer greater torque and a longer fatigue life as an alternative to the hollow/key connection.

Die Keilwellen haben Zähne mit entsprechenden Nuten eines Kupplungsstückes und übertragen das Drehmoment mit Einhaltung des Winkels zwischen Ihnen.

Alternativ zur Verbindung von Schlüssel/Keilnut, die Keilwellen bieten mehr Drehmoment und höhere Lebensdauer an.

AS - ACC - F - BT - BTV - BTF

Posizione accessori
Accessory position
Position der Zubehör

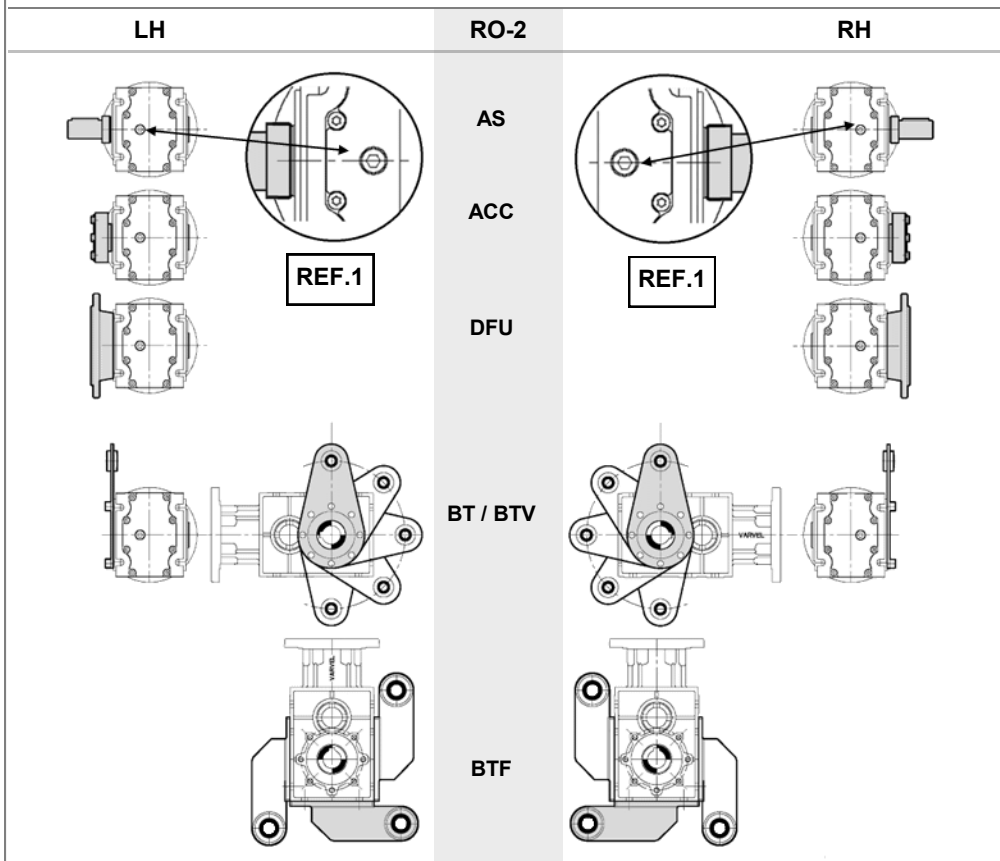

Gli accessori, nelle posizioni di lavoro RH e LH, fanno riferimento alla posizione di montaggio H1 a pag. 12 e sono viste dal coperchio del lato inferiore del riduttore.

Il lato della carcassa con il tappo per l'olio (REF.1) è la esatta identificazione del lato di riferimento del coperchio .

Se l'accessorio viene richiesto montato in fabbrica, l'ordine è considerato in sospenso fino alla determinazione del lato RH o LH.

Per gli accessori BT-BTV-BTF e per le altre posizioni di montaggio, riferirsi al Servizio Clienti.

Le posizioni standard degli accessori sono evidenziate in colore grigio.

The accessories in the working positions RH and LH refer to the mounting position H1 on p. 12 and are seen from the cover of the lower side of the reducer.

The side of the casing with the oil plug (REF.1) is the exact identification of the reference side of the cover.

The order remains pending until the RH or LH side is determined if the accessory must be factory-mounted.

For BT-BTV-BTF accessories and other mounting positions, please refer to Customer Service.

The standard accessory positions are indicated with grey highlights.

Die Zubehöre, hier als RH und LH definiert, beziehen sich auf H1 Einbaulage auf Seite 12 und werden von der Deckel auf der Unterseite des Getriebes entsprechend gesehen.

Die Seite des Gehäuses mit der Schraube (REF.1), wie gezeigt ist die genaue Identifizierung der Referenzseite.

Wenn das Zubehör am haus angeforderte gebaut wird die Reihenfolge gehalten, bis Seite RH oder LH definiert ist.

Für die Zubehöre BT-BTV-BTF und andere Einbaulagen entnehmen Sie bitte dem Kundendienst beziehen.

Die Standardpositionen des Zubehörs sind in der Farbe grau hervorgehoben.



Componenti - Rotazione
Component parts - Rotation
Bauelemente - Drehrichtung

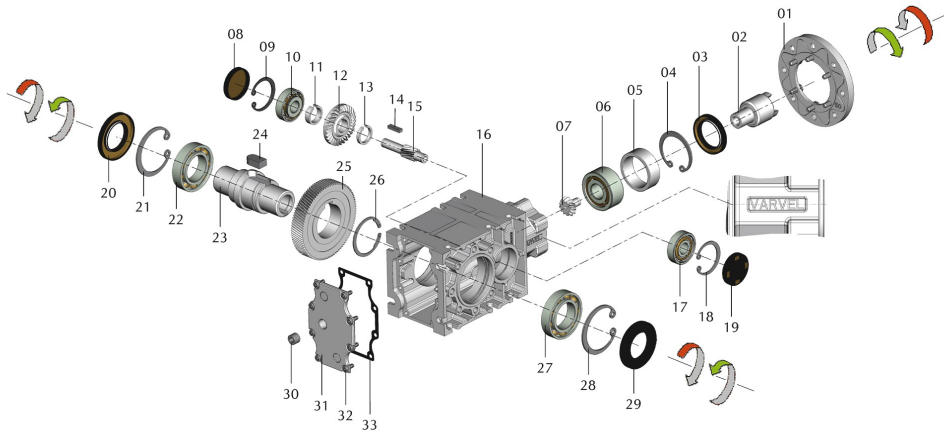

Pos.	Descrizione	Description	Beschreibung	Pos.	Descrizione	Description	Beschreibung
01	Flangia motore	Motor flange	Motorflansch	18	Anello Seeger	Snap ring	Seegerring
02	Albero entrata	Input shaft	Eingangswelle	19	Paraolio	Oil seal	Wellendichtung
03	Paraolio	Oil seal	Wellendichtung	20	Paraolio	Oil seal	Wellendichtung
04	Anello Seeger	Snap ring	Seegerring	21	Anello Seeger	Snap ring	Seegerring
05	Distanziale	Spacer	Distanzring	22	Cuscinetto	Bearing	Lager
06	Cuscinetto	Bearing	Lager	23	Albero uscita	Output shaft	Ausgangswelle
07	Pignone conico	Conical pinion	Kegelritzel	24	Chiavetta	Key	Paßfeder
08	Paraolio	Oil seal	Wellendichtung	25	Ruota	Gear	Rad
09	Anello Seeger	Snap ring	Seegerring	26	Anello Seeger	Snap ring	Seegerring
10	Cuscinetto	Bearing	Lager	27	Cuscinetto	Bearing	Lager
11	Distanziale	Spacer	Distanzring	28	Anello Seeger	Snap ring	Seegerring
12	Ruota conica	Conical gear	Kegelrad	29	Paraolio	Oil seal	Wellendichtung
13	Distanziale	Spacer	Distanzring	30	Tappo	Plug	Stopfen
14	Chiavetta	Key	Paßfeder	31	Coperchio	Cover	Deckel
15	Pignone	Pinion	Ritzel	32	Vite	Screw	Schraube
16	Carcassa	Housing	Gehäuse	33	Guarnizione	Gasket	Dichtung
17	Cuscinetto	Bearing	Lager				

**Motori
Motors
Motoren**

B5

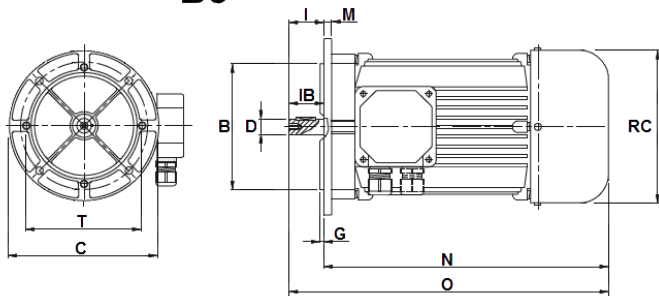

B14

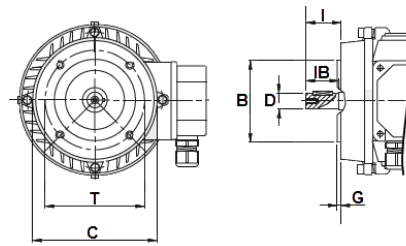

Taglia Size Größe	2 poli - poles - Polig 2800 rpm		4 poli - poles - Polig 1400 rpm		6 poli - poles - Polig 900 rpm		Flangia - Flange Flansch B / C / T	Albero Shaft Welle D x l	G	IB	N	O
	kW	kg	kW	kg	kW	kg						
T56A T56B	0.09 0,12	2.6 3.0	0.06 0.09	2.9 3.2	---	---	B5 - 120 / 100 / 80 B14 - 80 / 65 / 50	9 x 20	3.0 2.5	20	176	196
T63A T63B T63C	0.18 0.25 0.37	4.0 4.2 4.7	0.12 0.18 0.25	3.7 4.2 4.7	0.09 0.12 ---	4.2 4.5 ---	B5 - 140 / 115 / 95 B14 - 90 / 75 / 60	11 x 23	3.0 2.5	23	197	220
T71A T71B T71C	0.37 0.55 0.75	5.2 6.0 7.0	0.25 0.37 0.55	5.0 5.8 6.5	0.18 0.25 0.37	5.6 6.0 6.5	B5 - 160 / 130 / 110 B14 - 105 / 85 / 70	14 x 30	3.5 2.5	30	211	241
T80A T80B T80C	0.75 1.1 1.5	8.7 10 11.2	0.55 0.75 1.1	8.1 9.1 11	0.37 0.55 0.75	6.8 9.6 10	B5 - 200 / 165 / 130 B14 - 120 / 100 / 80	19 x 40	3.5 3.0	40	250	290
T90S T90L T90LB	1.5 2.2 3	12 14.5 15	1.1 1.5 2.2	11.7 14.4 17.6	0.75 1.1 1.5	11.3 14.4 15.5	B5 - 200 / 165 / 130 B14 - 140 / 115 / 95	24 x 50	3.5 3.0	50	262 287	312 337
T100A T100B	3 4	20 24	2.2 3	17.6 22.5	1.5 2.2	18.8 19.8	B5 - 250 / 215 / 180 B14 - 160 / 130 / 110	28 x 60	4.0 3.5	60	309	369
T112A T112MC	5.5 7.5	29.3 34	4 5.5	29 35.7	3 ---	30 ---	B5 - 250 / 215 / 180 B14 - 160 / 130 / 110	28 x 60	4.0 3.5	60	335	395
T132S T132M T132ML T132MC	7.5 9.2 11 ---	38.4 48.2 52.5 ---	5.5 7.5 9.2 11	39 48.5 56.5 64	4.5 5 7.5 ---	47.6 50.7 47 ---	B5 - 300 / 265 / 230 B14 - 200 / 165 / 130	38 x 80	4.0 4.0 ---	80	357 395 421	437 475 501
T160M T160L T160MC	15 18.5 22	77.5 92 107	11 15 18.5	73 88.5 97.5	7.5 11 15	70.0 87.0 124	B5 - 350 / 300 / 250 B14 - 250 / 215 / 180	42 x 110	5.0 4.0	110	530	640
T180M T180L	22 ---	121 ---	18.5 22	118 128	15 ---	124 ---	B5 - 350 / 300 / 250	48 x 110	5.0	110	620	730

Dimensioni e pesi non impegnativi

Not binding dimensions and weights

unverbindliche Abmessungen u. Gewichte

ATEX

Directive 2014/34/UE
Regulation 2016/1107/UK

La Direttiva Europea 2014/34/UE-ATEX riguarda non solo apparecchi elettrici ma tutte le macchine e organi di comando che sono destinati, soli o combinati, per funzionare in atmosfere potenzialmente esplosive nei territori della Comunità Europea.

I riduttori sono identificati nella Direttiva come «componenti», pertanto privati di loro funzione autonoma, ma essenziali per il funzionamento di apparecchi e di sistemi di protezione destinati alla produzione, trasporto, immagazzinamento, misurazione, regolazione e conversione d'energia e trasformazione dei materiali che, per le loro proprie potenzialità d'infiammabilità, rischiano di provocare l'innescò di un'esplosione.

I riduttori VARVEL-ATEX sono fabbricati con

- carcassa e coperchi in materiale metallico, contenenti gli elementi di trasmissione montati su cuscinetti a sfere o a rulli;
- paraolio in fluoro-elastomero FKM (Viton) sugli alberi di entrata e di uscita;
- quantità di lubrificante idonea per assicurare il funzionamento del progetto;
- viteria sigillata con pasta frena-filetti.

La serie VARVEL RO-2 è conforme alle specifiche di progetto richieste dal

- Gruppo II
- Categoria 2 e 3
- zona 1 e zona 2 per funzionamento in zone con pericolo di esplosione in presenza di gas
- zona 21 e zona 22 per funzionamento in zone con pericolo di esplosione in presenza di polveri combustibili

I prodotti VARVEL-ATEX sono marcati per la versione con

- cava/chiavetta in entrata

The European Directive 2014/34/EC-ATEX relates not only to electric devices but to all the machines and driving units destined, alone or combined, to operate in potentially explosive environments within European Community territory.

The gearboxes are identified as «components» in the Directive and therefore, deprived of their autonomous function but essential for the operation of equipment and protective systems intended for production, transport, storage, measurement, adjustment and conversion of energy and transformation of materials that, due to their own flammability potential, are likely to trigger an explosion.

The gearboxes VARVEL-ATEX are manufactured

- with metallic housings and covers, containing the driving gears fitted on ball or roller bearings;
- FKM-Fluor-elastomer (Viton) oil seals on input and output shafts;
- the needed oil quantity to ensure the unit operation;
- sealed thread screws with sealing paste.

VARVEL RO-2 Series conforms to design directions required for

- Group II
- Category 2 and 3
- zones 1 and 2 for operation in zones with risk of explosion in presence of gas
- zones 21 and 22 for operation in zones with risk of explosion in presence of combustible dust

The VARVEL-ATEX products are marked for the

- key/keyway input version

Die Europäische Richtlinie 2014/34/EG-ATEX gilt nicht nur für elektrische Ausrüstungen, sondern auch für alle Arten von Maschinen und Steuerungsteile, allein oder kombiniert, für den Gebrauch in potentiell explosiver Atmosphäre in den Gebieten der Europäischen Gemeinschaft.

Die Getriebe sind in der Richtlinie als "Komponenten" identifiziert, von daher ihre autonome Funktion, aber wesentlich für den Betrieb von Geräten und Schutzsystemen für die Produktion, Transport, Lagerung, Messung, Regelung und Umwandlung von Energie und Verarbeitung von Materialien, die wegen ihrer eigenen potenzieller Entflammbarkeit, die Auslösung einer Explosion riskieren.

Die VARVEL-ATEX Getriebe sind hergestellt mit

- Gehäuse und Deckel in Metall, beinhaltet Getriebe montiert auf Kugel- oder Rollenlager;
- FKM-Fluorelaste (Viton) Dichtungen auf Eingangs- und Ausgangswellen;
- ausreichende Ölmenge, um das Funktionieren des Projekts zu gewährleisten;
- Schrauben sind mit Schraubensicherungs-paste abgedichtet.

Die VARVEL RO-2 Serie ist entsprechend mit die Konstruktionsanforderungen gebeten von

- Gruppe II,
- Kategorie 2 u. 3,
- Zone 1 und Zone 2 für Betrieb in Zonen mit Explosionsgefahr in der Gegenwart von Gas,
- Zone 21 und Zone 22 für Betrieb in Zonen mit Explosionsgefahr in der Gegenwart von Brennstaub.

Die Produkte VARVEL-ATEX sind markiert für die

- Passfeder/Nut Eingangsausführung



II 2 G Ex h IIC T4 Gb IP66 T_{amb} -20 /+55°C
II 2 D Ex h IIIC T135°C Db IP66 T_{amb} -20 /+55°C

chiave di lettura del Codice ATEX

II - gruppo II (industrie di superficie)
2, 3 - categoria (2, 3)
G, D - Atmosfera esplosiva (gas, polveri)
Ex h - modo di protezione
IIC, IIIC - gruppo di esplosione (gas, polveri)
T4 - classe di temperatura (gas)
T135°C - massima temperatura superficiale (polveri)
Gb, Db - EPL - Explosion Protection Level: (gas, polveri)
IP66 - protezione riduttore
T_{amb} - temperatura ambiente -20 /+55°C

key to ATEX Code

II - group II (surface industries)
2, 3 - category (2, 3)
G, D - explosive environment (gas, dust)
Ex h - mode of protection
IIC, IIIC - group of explosion (gas, dust)
T4 - class of temperature (gas)
T 135°C - max. temperature of surface (dust)
Gb, Db - EPL - Explosion Protection Level (gas, dust)
IP66 - protection of gearbox
T_{amb} - ambient temperature -20 /+55°C

Leseschlüssel des ATEX - Code

II - Gruppe II (Oberfläche-Industrien)
2, 3 - Kategorie (2, 3)
G, D - explosionsfähige Atmosphäre (Gas, Staube)
Ex h - Schutzart
IIC, IIIC - Explosion-Gruppe (Gas, Staube)
T4 - Temperatur-Klasse
T 135°C - Maximale Oberflächentemperatur (Staube)
Gb, Db - EPL - Explosion Protection Level (Gas, Staube)
IP66 - Getriebes Schütz
T_{amb} - Zimmertemperatur -20 /+55°C

Sostanze Substances Substanzen	Zone Zones Zonen	Categorie Categories Kategorien	EPL (Equipment Protection Level)
Gas, Vapori, Nebbie Gas, Vapours, Cloud Gas, Dämpfe, Nebel	0	1G	Ga
	1	2G	Gb
	2	3G	Gc
Polveri Dust Stäube	20	1D	Da
	21	2D	Db
	22	3D	Dc

Chiave di lettura - Key code - Leserschlüssel

Zona Zone	0	Presenza continua di gas esplosivo Continuous occurrence of explosive gas Dauerndes Vorhandensein explosiver Gase
	1	Presenza occasionale di gas esplosivo Occasional occurrence of explosive gas Gelegentliches Vorhandensein explosiver Gase
	2	Presenza improbabile di gas esplosivo Unlikely occurrence of explosive gas Unwahrscheinliches Vorhandensein explosiver Gase
	20	Presenza continua di polveri esplosive Continuous occurrence of explosive dust Dauerndes Vorhandensein explosiver Staub
	21	Presenza occasionale di polveri esplosive Occasional occurrence of explosive dust Gelegentliches Vorhandensein explosiver Staub
	22	Presenza improbabile di polveri esplosive Unlikely occurrence of explosive Unwahrscheinliches Vorhandensein explosiver Staub
Categoria Category Kategorie	1G, 1D	Apparecchi a livello di protezione molto alto Equipment with very high protection level Geräte mit sehr hohem Schutz (
	2G, 2D	Apparecchi a livello di protezione alto Equipment with high protection level Geräte mit hohem Schutz
	3G, 3D	Apparecchi a livello di protezione normale Equipment with normal protection level Geräte mit normalem Schutz
EPL	Ga, Da	Livello di protezione molto alto Very high level of protection Sehr hohes Schutzniveau
	Gb, Db	Livello di protezione alto High level of protection Hohes Schutzniveau
	Gc, Dc	Livello di protezione normale Normal level of protection Normales Schutzniveau

N.B. - I gas con temperatura di innesco superiore o uguale alla Classe T4=135 °C sono elencati a pag. 59 del catalogo "RO-2, edizione italiana".

Note - Gases with ignition temperature higher than or equal to Class T4=135 °C are listed on page 59 of the RO-2 catalogue, English edition.

Anm. - Gase mit einer Zündtemperatur höher oder gleich Klasse T4=135 °C sind auf Seite 59 des "deutschen RO-2" Katalogs aufgeführt.

Attenzione !

I riduttori VARVEL-ATEX non sono certificati per funzionamento nelle aree tratteggiate.

Attention !

VARVEL-ATEX gearboxes are not certified for operation in hatched areas.

Vorsicht !

Die Getriebe VARVEL-ATEX sind für den Anbau in die Gestrichelte Zone nicht zertifiziert.

ISTRUZIONI D'USO E MANUTENZIONE (manuale completo su www.varvel.com)

Ai sensi della Direttiva Macchine 2014/34/CE e relativa Linea Guida, i riduttori e i variatori di velocità sono considerati "elementi separati di macchine che non hanno un'applicazione specifica e che sono destinati ad essere incorporati nella macchina. La macchina completa dotata di questi componenti deve soddisfare i requisiti essenziali pertinenti di sicurezza e tutela della salute" della citata Direttiva.

Installazione

Accertarsi che il gruppo da installare abbia le caratteristiche atte a svolgere la funzione richiesta e che la posizione di montaggio sia coerente con quanto ordinato. Tali caratteristiche sono deducibili dalla targhetta d'identificazione apposta sul riduttore. Effettuare la verifica della stabilità del montaggio affinché non si verifichino vibrazioni o sovraccarichi durante il funzionamento.

Funzionamento

Il riduttore può essere collegato per rotazione oraria o antioraria. Arrestare immediatamente il riduttore in caso di funzionamento difettoso o di rumorosità anomala, rimuovere il difetto o ritornare l'apparecchio alla fabbrica per un'adeguata revisione. Se la parte difettosa non è sostituita, anche altri componenti possono essere danneggiati con conseguenti ulteriori danneggiamenti e più scarsa possibilità di risalire alle cause.

Manutenzione

Sebbene i gruppi siano provati con funzionamento senza carico prima della spedizione, è consigliabile non usarli a carico massimo durante le prime 20-30 ore di funzionamento affinché le parti interne possano adattarsi reciprocamente. I riduttori sono spediti già riempiti con olio sintetico a lunga durata e, se occorre sostituire o rabboccare il lubrificante, non mescolare oli a base sintetica con oli a base minerale.

Movimentazione

In caso di sollevamenti con paranco, utilizzare posizioni di aggancio sulla struttura della carcassa, golfari ove esistenti, fori dei piedi o sulle flange, evitando tutte le parti mobili.

Verniciatura

Qualora il gruppo subisca una verniciatura successiva, è necessario proteggere accuratamente gli anelli di tenuta, i piani di accoppiamento e gli alberi sporgenti.

Conservazione prolungata a magazzino

Per permanenze maggiori di tre mesi, è consigliata l'applicazione di antiossidanti su alberi esterni e piani lavorati, e di grasso protettivo sui labbri dei paraoli.

Gestione Ambientale del prodotto

In conformità alla Certificazione Ambientale ISO 14001, sono suggerite le seguenti indicazioni per lo smaltimento del nostro prodotto:

- i componenti del gruppo che vengono rottamati debbono essere consegnati a centri di raccolta autorizzati per i materiali metallici;
- gli oli ed i lubrificanti raccolti dal gruppo devono essere smaltiti consegnandoli ai Consorzi Oli esausti;
- gli imballi a corredo dei gruppi (pallet, cartone, carta, plastica, ecc.) vanno avviati per quanto più possibile al recupero/riciclo, consegnandoli a ditte autorizzate per le singole classi di rifiuto.

OPERATION & MAINTENANCE INSTRUCTIONS (complete manual on www.varvel.com)

According to the Machinery Directive 2014/34/EC and its Guideline, gearboxes and speed variators are considered "separate elements of machines that do not have a specific application and are intended to be incorporated into the machine. The complete machine equipped with these components must meet the relevant essential health and safety requirements" of the Directive.

Installation

Ensure that the unit to be installed has the characteristics required to perform the required function and that the mounting position is consistent with the order. These characteristics can be deduced from the identification plate on the gearbox. Verify the mounting stability so that no vibration or overload occurs during operation.

Operation

The reducer can be connected by clockwise or counterclockwise rotation. Stop the gearbox immediately in the event of faulty operation or abnormal noise, remove the defect or return the unit to the factory for proper overhaul. If the defective part is not replaced, other components can also be damaged, resulting in further damage and less chance of tracing the causes.

Maintenance

Although the assemblies are tested without loading before shipment, it is advisable not to use them at maximum load during the first 20-30 hours of operation so that the internal parts can adapt to each other. The gearboxes are shipped already filled with long-life synthetic oil and, if it is necessary to replace or top up the lubricant, do not mix synthetic-based oils with mineral-based oils.

Handling

In the case of lifting with a hoist, use the hooking positions on the structure of the body, where they exist, holes in the feet or on the flanges, avoiding all moving parts.

Painting

If the units have to be subjected to a painting process, the sealing rings, the coupling planes and the protruding shafts must be carefully protected.

Prolonged storage in stock

For stays longer than three months, the application of antioxidants on external shafts and machined surfaces, and of protective grease on the lips of oil seals is considered.

Environmental Management of the product

In accordance with the ISO 14001 Environmental Certification, the following indications are suggested for the disposal of our product:

- the metal components of the unit being scrapped to be delivered to authorised collection centres for metallic materials;
- the oils and lubricants collected by the unit to be disposed of and delivered to the Consortia Waste Oils;
- the packaging of the units (pallets, cardboard, paper, plastic, etc.) to be sent as far as possible to recovery/ recycling, delivering them to authorized companies for the individual waste classes.

BETRIEBS- u. WAR-TUNGSANWEISUNGEN (vollständiges Handbuch auf www.varvel.com)

Gemäß der Maschinenrichtlinie 2014/34/EG und der zugehörigen Richtlinie gelten Getriebe und Verstellgetriebe als "separate Elemente von Maschinen, die keine spezifische Anwendung haben und die in der Maschine eingebaut werden sollen. Die gesamte Maschine, die mit diesen Komponenten ausgerüstet ist, muss den einschlägigen grundlegenden Sicherheits- und Gesundheitsanforderungen der vorgenannten Richtlinie entsprechen.

Aufstellung

Vor der Aufstellung ist zu prüfen, dass die Antriebseinheit in Bezug auf die Betriebsbedingungen richtig ausgewählt wurde und die Einbaulage mit der Bestellung übereinstimmt. Angaben hierüber sind auf dem Typenschild zu finden. Die Stützkonstruktion für die Getriebe ist so stabil auszuführen, dass keine Schwingungen oder Überlastungen auftreten, eventuell sind elastische Kupplungen oder Drehmomentbegrenzer zu verwenden.

Inbetriebnahme

Die Antriebseinheit kann in beiden Drehrichtungen eingesetzt werden. Die Einheit müsst sofort angehalten werden, wenn ein unzulässiger Lauf oder unerwartete Geräusche auftreten.

Das fehlerhafte Teil ist zu ersetzen oder die Einheit ist zur Überprüfung einzuschicken, Falls das fehlerhafte Teil nicht ersetzt wird, kann dies zu weiteren Schäden an anderen Bauteilen führen, was eine Feststellung der Ursachen sehr schwierig machen kann.

Wartung

Obwohl die Einheiten vor der Auslieferung im Leerlauf getestet wurden, ist es ratsam sie in den ersten 20-30 Stunden nicht mit Vollast zu betreiben, um ein einwandfreies Einlaufen zu gewährleisten. Die Einheiten werden entsprechend den Angaben auf dem Typenschild mit synthetischem Schmierstoff Lebensdauer geschmiert ausgeliefert. Bei einem eventuellen Ölwechsel oder Nachfüllen darf der Schmierstoff nicht mit Mineralöl vermischt werden.

Handhabung und Transport

Beim Heben und Transport ist auf standsichere Lage und sorgfältige Befestigung geeigneter Hebevorrichtungen zu achten, Bewegliche Teile dürfen nicht zum Anheben benutzt werden.

Anstrich

Beim Erneuern oder dem zusätzlichen Aufbringen eines Anstriches sind die Dichtungen, Kupplungssitze und Wellen sorgfältig zu schützen.

Langzeitlagerung

Die Einlagerung der Einheiten muss trocken und staubfrei erfolgen, Bei einer Einlagerungszeit über 3 Monate sind bearbeitete Flächen und Wellen mit Rostschutzmitteln zu besprühen, Dichtlippen sind mit Fett zu schützen.

Entsorgung

Gemäß der Umweltzertifizierung ISO 14001 werden folgende Hinweise zur Entsorgung unseres Produkts empfohlen:

- die zu verschrotteten Bauteilen der Gruppe müssen bei autorisierten Sammelstellen für metallische Werkstoffe geliefert werden;
- die von der Gruppe gesammelten Öle und Schmiermittel müssen entsorgt werden, indem sie an die Altölkonsortien geliefert werden;
- die zu den Gruppen gehörenden Verpackungen (Paletten, Pappe, Papier, Kunststoff etc.) sind so weit wie möglich der Wiederverwertung zuzuführen und bei den für die einzelnen Abfallklassen zugelassenen Unternehmen abzugeben.

Liberatoria

Il presente catalogo annulla e sostituisce i precedenti.

Le dimensioni e pesi non sono impegnativi VARVEL si riserva il diritto di apportare modifiche senza preavviso.

È vietata la riproduzione anche parziale senza preventiva autorizzazione.

Disclaimer

This catalogue cancels and replaces the previous ones.

Dimensions and weights are not binding. VARVEL reserves the right to make changes without notice.

Reproduction, even partial, is prohibited without prior authorization.

Haftungsausschluss

Dieser Katalog löscht und ersetzt die vorherigen Kataloge.

Abmessung u. Gewichte sind unverbindliche. VARVEL behält sich das Recht vor, unangekündigte Änderungen vorzunehmen.

Die teilweise Vervielfältigung ohne vorherige Genehmigung ist untersagt.

D00-RO-2-STD-itende-ED04-REV00

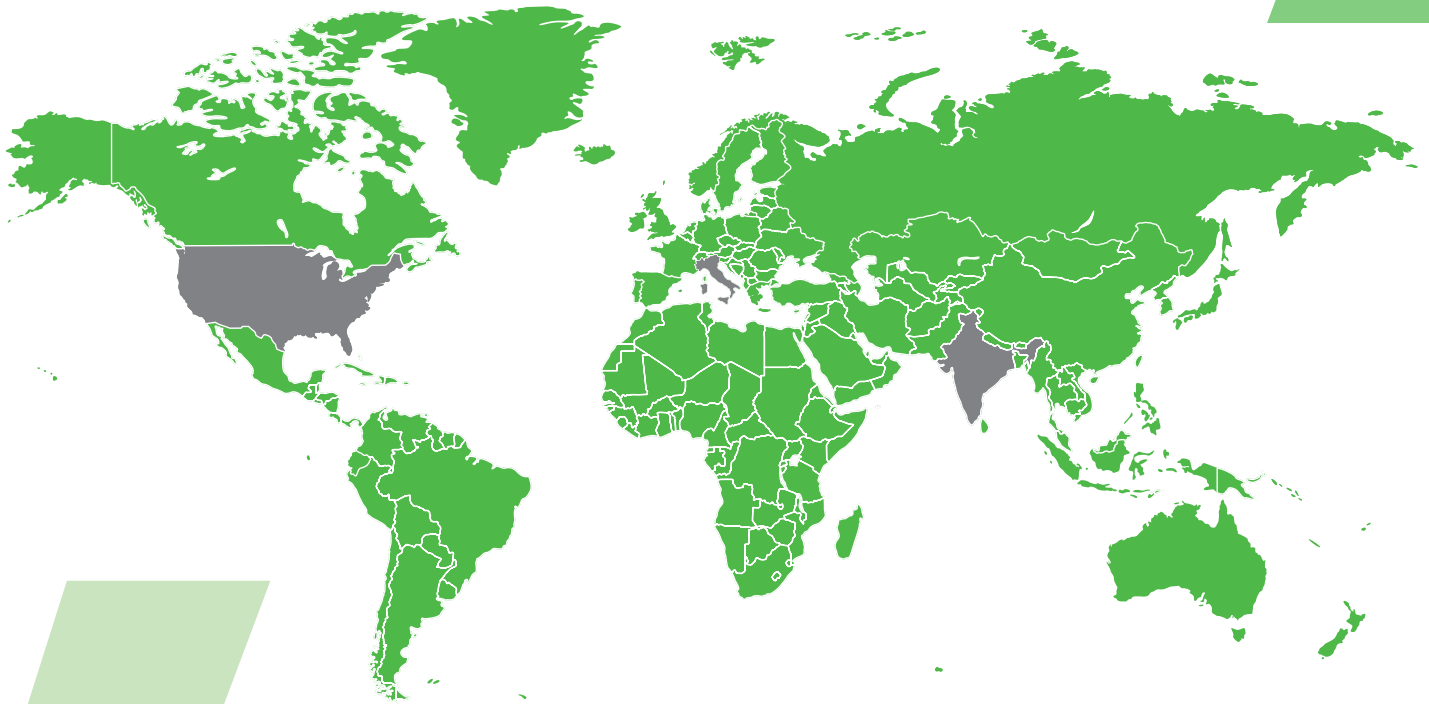

2 **Filiali estere in India e USA**
Foreign subsidiaries, one in India, one in the USA
Auslandsfilialen: in Indien und in den USA



60 **Oltre 60 anni di storia e successi internazionali**
Over 60 years of history and international success
Über 60 Jahre Unternehmensgeschichte und internationale



100 **Rete globale con oltre 100 partner commerciali**
A global network with over 100 commercial partners
Globales Vertriebsnetz mit mehr als 100 Handelspartnern

India subsidiary:
MGM-VARVEL Power Transimission Pvt Ltd
Warehouse N. G3 and G4 | Ground Floor
Indus Valley's Logistic Park | Unit 3
Mel Ayanambakkam Vellala Street
Chennai - 600 095 | Tamil Nadu | INDIA
info@mgmvarvelindia.com
www.mgmvarvelindia.com

USA subsidiary:
VARVEL USA LLC
2815 Colonnades Court
Peachtree Corners, GA 30071 | USA
T 770-217-4567 | F 770-255-1978
info@varvelusa.com
www.varvelusa.com

