

### Section A

<b>Program</b>	A1- A2
<b>Description</b>	A3 - A6

### Section B

<b>Request for quotation</b>	B1
<b>Selection</b>	
Mechanical power rating	B2
Thermal rating	B3
Detailed example of selection	B4
<b>Tables</b>	
Mechanical powers - torques - exact ratios	B5 & B7
Thermal powers	B6 & B8
Overhung loads on solid low speed shaft	B9
Moments of inertia	B10
Arrangements with motor	B11

### Section C

<b>Dimensional drawings</b>
Index on page C

# STANDARDIZED GEAR UNITS FOR MINING APPLICATIONS Program

## Parallel shafts

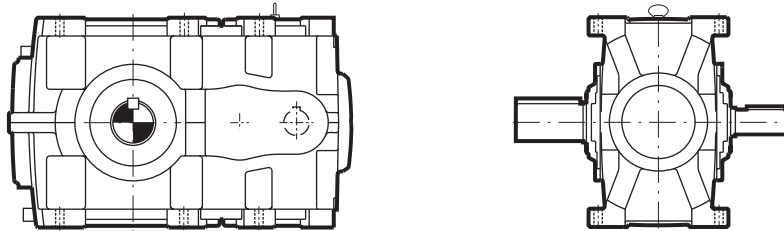

**T**  
(1000 lbf.in)

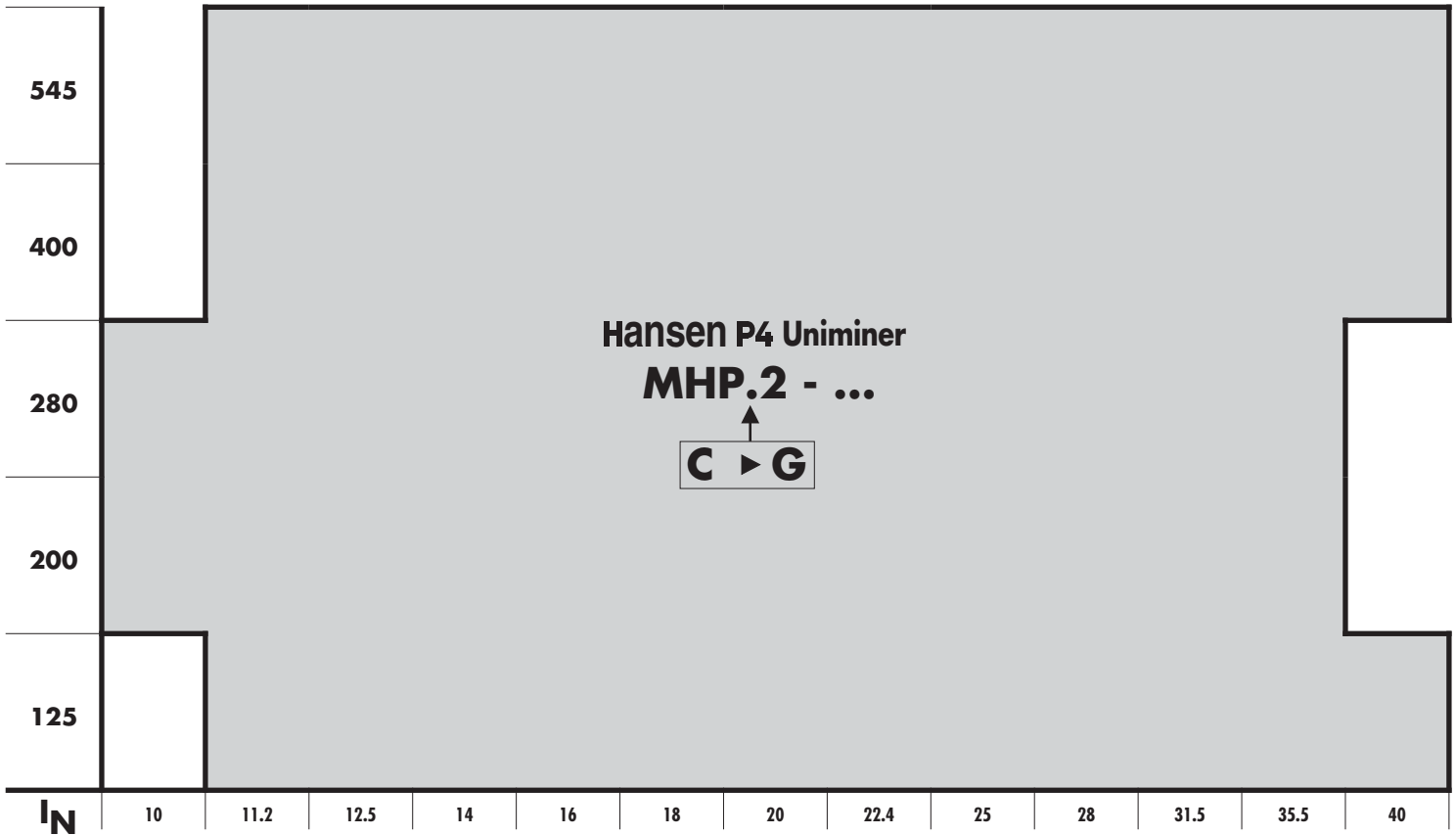

T (1000 lbf.in): nominal torque at low speed shaft

$I_N$ : nominal ratio

# STANDARDIZED GEAR UNITS FOR MINING APPLICATIONS Program

## Right-angle shafts

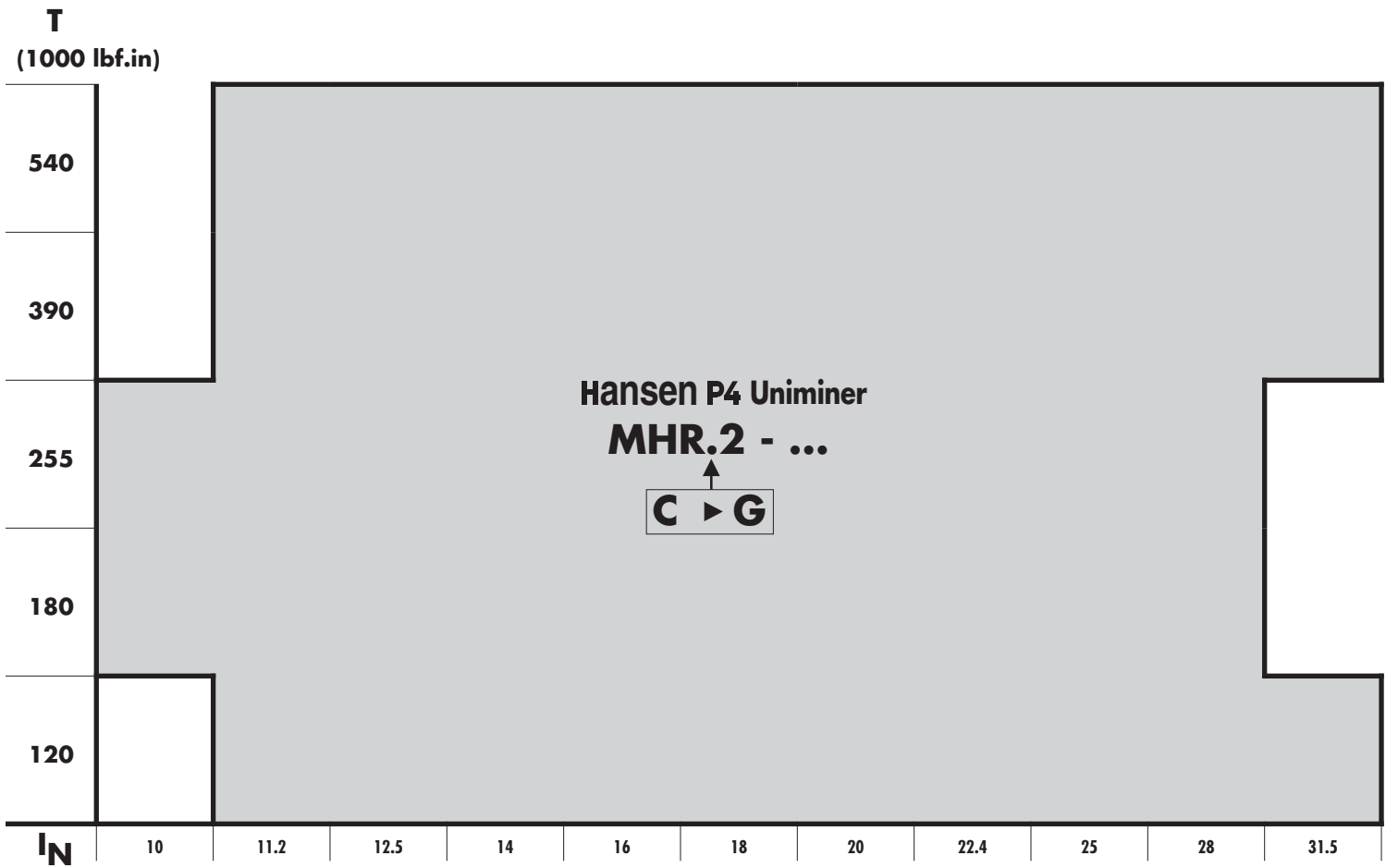
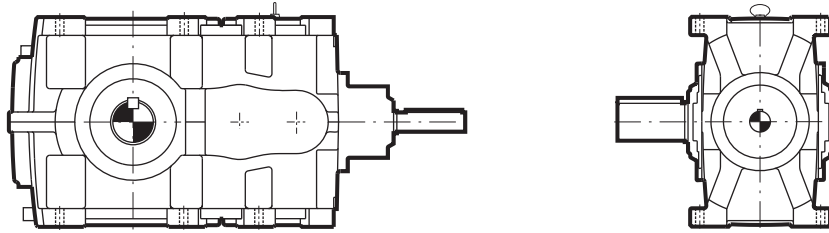

T (1000 lbf.in): nominal torque at low speed shaft

I<sub>N</sub> : nominal ratio

# DESCRIPTION

## STANDARDIZED GEAR UNITS FOR MINING APPLICATIONS

### The gear unit

#### Coding

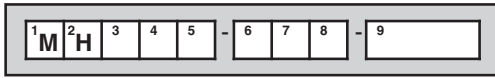

#### Type

- 1 : Series **M** : Hansen P4 Uniminer  
 2 : **H** : Horizontal low speed shaft  
 3 : **P** : Parallel shafts  
**R** : Right-angle shafts  
 4 : Size: **C** -> **G**  
 5 : Number of stages: **2**

#### Shaft arrangement

- 6 : High speed shaft extension: **C** : right-angle  
**L** : left  
**R** : right  
**T** : two shaft extensions

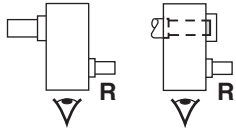

- 7 : Low speed shaft extension: **L** : left  
**R** : right  
**T** : two shaft extensions

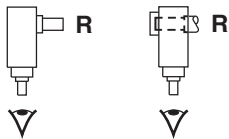

- 8 : Low speed shaft type: **N** : normal solid shaft  
**D** : shrink disc hollow shaft  
**K** : keyway hollow shaft

#### Ratio

- 9 : Nominal ratio

### Basic components

#### Helical and spiral bevel gears

Designed and rated in accordance with AGMA, ISO for maximum load capacity, minimum losses and quiet operation.

The rating tables show the mechanical power ratings P expressed in hp, i.e. the power which the gear unit can transmit during 10h/day, at uniform load, whereby 5 peak torques up to 200% of the nominal torque and lasting not more than 5 seconds each, are allowed.

The mechanical power ratings shown in the tables relate respectively to input speeds of 1750, 1460, 1160 and 870 rpm at the high speed shaft. They are also valid for full load speed which are max. 3% lower than the synchronous speeds.

Interpolation will yield power rating values for intermediate speeds.

The power rating for speeds lower than 870 rpm is based on the continuous torque rating of that speed.

For input speeds exceeding 1750 rpm, please refer to Hansen.

All geared components are manufactured from alloy steel, gas carburized, hardened and precision ground.

The same applies to all intermediate and high speed shafts which are generally designed as pinion shafts.

#### Low speed shafts

The low speed shafts are in solid and hollow version.

Hollow low speed shaft with keyway or shrink disc connection.

The low speed shaft is designed to allow considerable overhung loads.

Permissible overhung loads on low speed shaft: see page B9.

#### Bearings

Heavy duty roller bearings of the tapered, cylindrical or spherical roller type.

Calculated in compliance with AGMA, ISO and methods of renowned bearing manufacturers.

To accommodate overhung load on the low speed shaft, heavy duty bearings are standard provided.

Permissible overhung load at the low speed shaft: see page B9.

#### Housings, bearing housings and covers

Made from grey pearlitic cast iron, ductile cast iron as an option.

Machined on CNC machining centers.

Designed to ensure strength and rigidity.

Unused tapped holes are plugged.

Horizontal split housing.

### Systems

#### Lubrication

Lubricants: mineral oils are normally used. Lubricants should always contain adequate EP-additives (refer to Service Manual).

The gear unit housing acts as a large sump.

Tilting of 3° in all directions is standard allowed. For larger tilting angles refer to Hansen.

The "flippable" housing allows for a multitude of mounting arrangements. When flipping the unit, the breather, the drain plug and the dipstick should be reversed by 180°.

For dusty environment, a rugged steel breather is available.

Grease points are centralized.

Checking of the oil level is done by means of the gear unit dipstick (always in the plugged position).

#### Cooling

Heat generated in the gear unit due to losses, can be dissipated by:

- natural cooling through the housing.
- additional fan cooling. Mounted on the high speed shaft. Free air entry at the suction side should be guaranteed. Split fan execution at the torque transmitting shaft end.

#### Sealing

- Static: • Generalized use of sealing compound  
 • Inspection covers on the gear unit: gasket

- Rotary: • High speed shaft:  
 - Dual grease purgable seals  
 - Oil Guard™ dynamic drain back function  
 - Split seal retainer  
 • Low speed shaft:  
 - Dual grease purgable seals  
 - Split seal retainer

**Instrumentation and options:** see pages A5-A6

### Accessories

**Motor lantern and scoop:** optional (page B11)

**Motor base:** optional (page B11)

#### Backstop: optional

- Sprag type, external, self contained, separately lubricated.
- Heavy duty execution.
- Torque arm mounted to the Hansen P4 Uniminer housing for ease of installation and maintenance.
- See page C9 for dimensions.

# DESCRIPTION

## STANDARDIZED GEAR UNITS FOR MINING APPLICATIONS

### Motors

Foot mounted or flange mounted motors may be used depending on the drive configuration.

An adjustable motor base on top of the gear unit or a scoop motor mount configuration is possible. Refer to page B11.

For more information on motors, refer to motor catalog.

Use of two speed motors: when changing speed with two speed motors, the low speed shaft of the gear unit has to be slowed down before the low speed, before energizing the slow speed winding.

Specifications of electric motors for hazardous locations: refer to motor catalog.

### Shipping conditions

#### Inspection prior to shipment

- Test run: all gear units are tested under no load.
- Conformity Check

#### Lubricants

- Hansen P4 Uniminer gear units are shipped without oil.
- Grease lubrication points are factory filled.

For information relating to **storage, handling, installation, start-up and maintenance**, refer to the service manual which is supplied together with each gear unit.

### Protection

#### Standard protection systems

- outer surface of housing: All units are standard provided with **basic epoxy painting** for indoor installation. A **humidity resistant painting** is provided for outdoor installation.
- inner surface of housing: oil resistant paint
- inner components: sprayed with rust preventing oil
- shaft extension: greased and protected with waxed waterproof paper.

#### Aggressive environment

- high resistant painting can be offered for additional protection.

#### Explanation of protection systems

##### Paint systems

#### • Basic epoxy painting

A two-component primer with excellent oil resistance and good adherence properties overcoated by a two-component high built epoxy coating with excellent corrosion protection properties in a dry environment.

#### • Humidity resistant painting for outdoor installation

A two-component high built epoxy paint is applied on top of the basic painting.

#### • High resistant painting

A two-component polyurethan paint applied on top of the humidity resistant paint.

### Sound pressure level

The chart shows the maximum anticipated sound pressure level at 3 FT., with 90% probability for Hansen P4 Uniminer gear units at 1200 and 1800 rpm input speed. Certified sound pressure level on request.

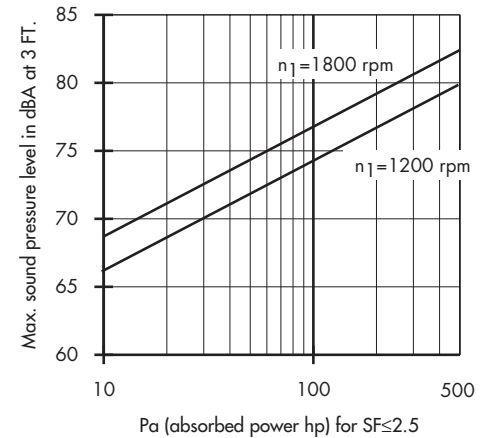

# DESCRIPTION

## STANDARDIZED GEAR UNITS FOR MINING APPLICATIONS

### MHP.2 - ...

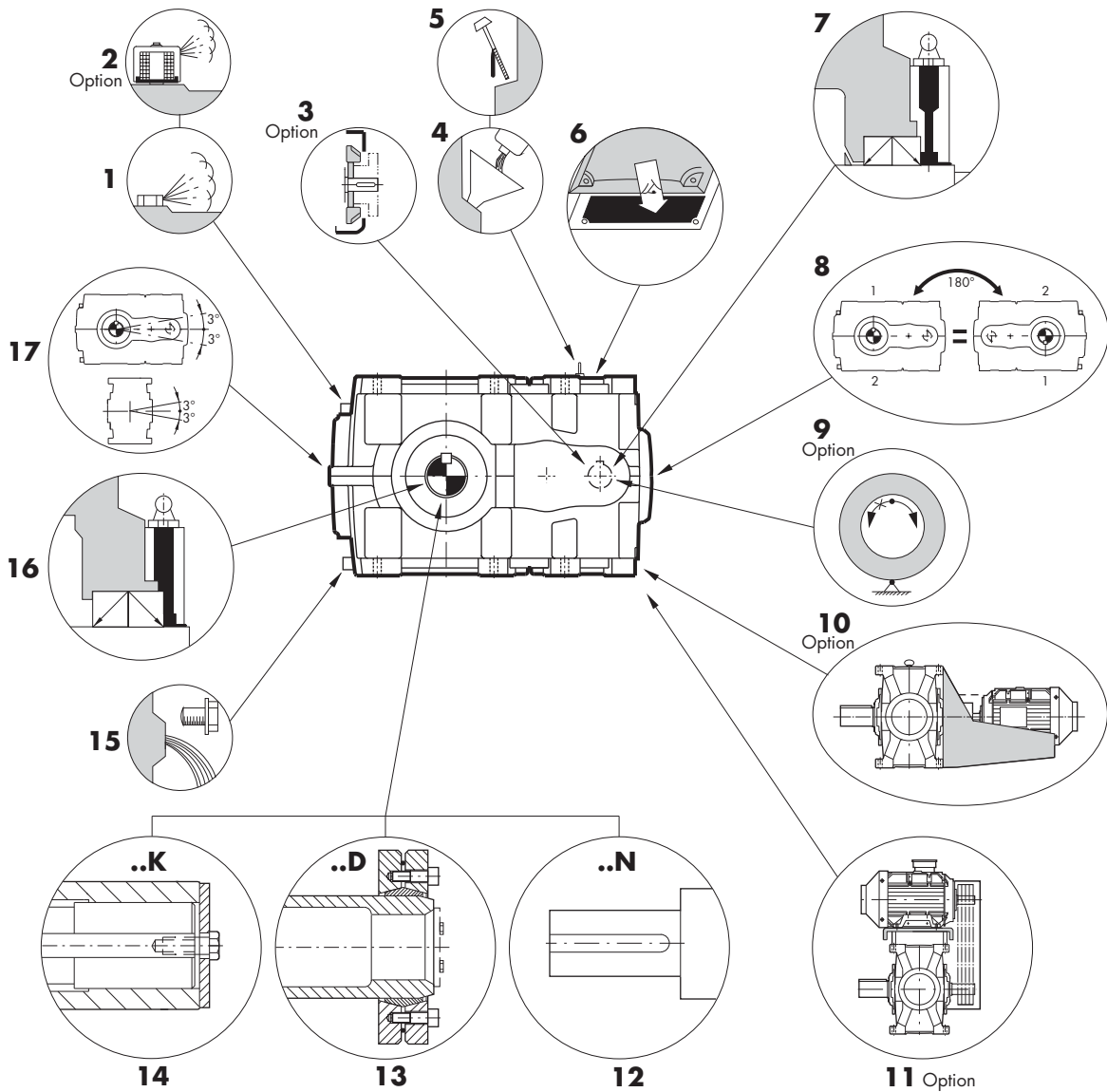

mark option required with

- 1 breather plug
- 2  dust proof breather plug
- 3  fan cooling: 1 or 2 fans possible
- 4 oil filler plug
- 5 dipstick
- 6 gear unit inspection covers
- 7 dual grease purgable seals and Oil-Guard™ dynamic drain back at the high speed shaft
- 8 flippable gear unit
- 9  backstop
- 10  scoop M5
- 11  motorbase M1
- 12 normal solid shaft
- 13 hollow shaft with shrink disc connection
- 14 hollow shaft with keyway
- 15 draining plug
- 16 dual grease purgable seals at the low speed shaft
- 17 standard tilting of 3° in all directions

# DESCRIPTION

## STANDARDIZED GEAR UNITS FOR MINING APPLICATIONS

### MHR.2 -...

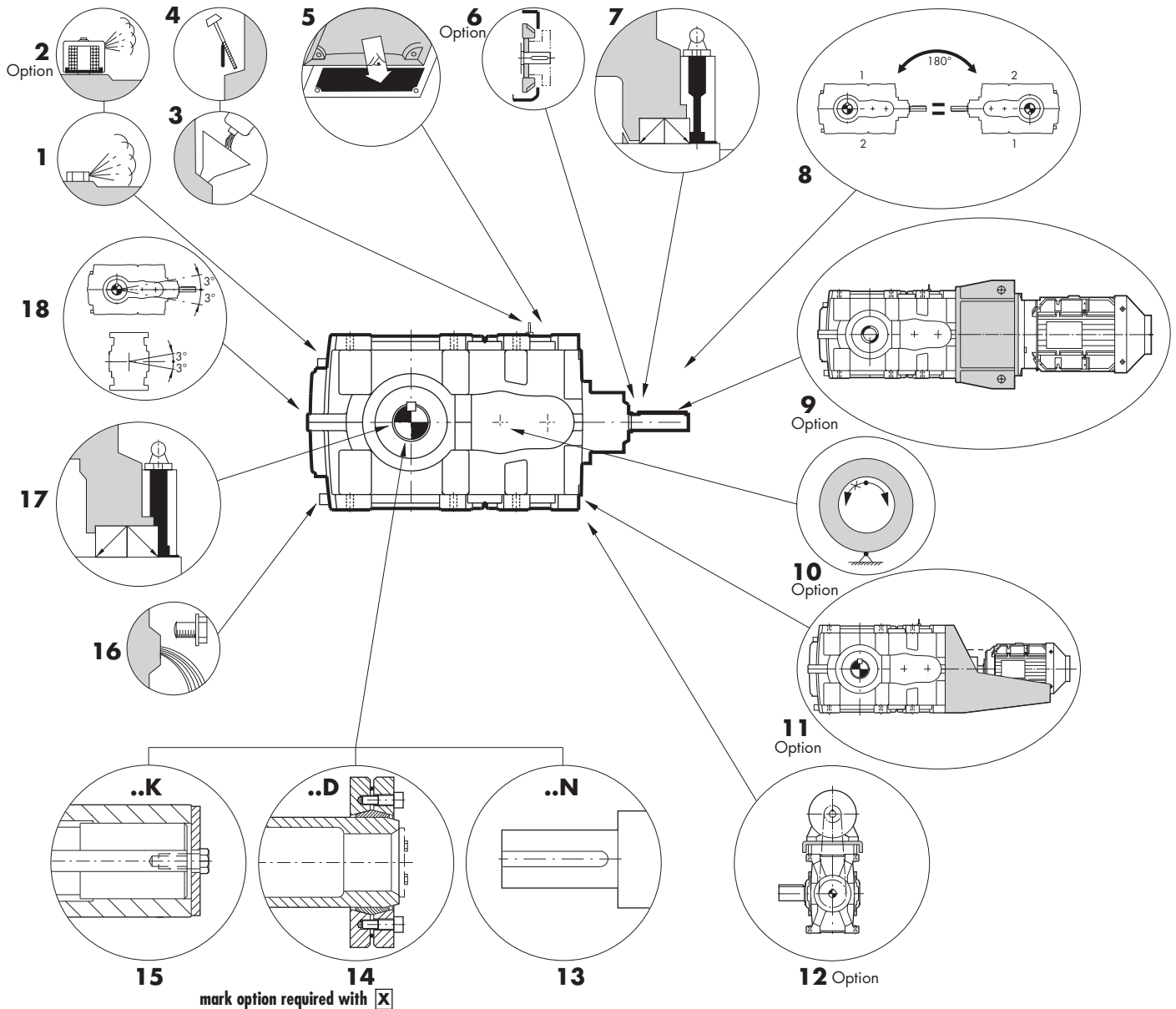

- mark option required with
- 1 breather plug
  - 2  dust proof breather plug
  - 3 oil filler plug
  - 4 dipstick
  - 5 gear unit inspection covers
  - 6  fan cooling: 1 fan possible
  - 7 dual grease purgable seals and Oil-Guard™ dynamic drain back at the high speed shaft
  - 8 flippable gear unit
  - 9  lantern housings for flexible and hydrodynamic coupling
  - 10  backstop
  - 11  scoop M8
  - 12  motorbase M3
  - 13 normal solid shaft
  - 14 hollow shaft with shrink disc connection
  - 15 hollow shaft with keyway
  - 16 draining plug
  - 17 dual grease purgable seals at the low speed shaft
  - 18 standard tilting of 3° in all directions





# SELECTION - MECHANICAL POWER RATING

# P

Code 1 **M** 2 **H** 3 4 5 **2** - 6 7 8 - 9

## Procedure

- 1
- 2
- 3
- 4
- 5
- 9
- 6
- 7
- 8

Series **M** : Hansen P4 Uniminer

Type **H** : Horizontal low speed shaft  
(inclination ≤ 3°)

Parallel shafts possible?  
Yes  **P** : Parallel shafts  
No  **R** : Right-angle shafts

Application  
Load conditions  
Prime mover

**SF** Service factor  
**SF**

### SERVICE FACTOR

Application	SF min					
	3h/24h		10h/24h		24h/24h	
	on Pa	on Pm	on Pa	on Pm	on Pa	on Pm
<b>Conveyors</b>						
Uniformly loaded or fed	1	1	1.25	1	1.25	1.1
Heavy duty	1.25	1	1.25	1.1	1.5	1.25
Reciprocating, shaking	1.5	1.25	1.75	1.5	2	1.75
Apron feeder, belt feeder	1	1	1.25	1.1	1.5	1.25
Screw feeder	1	1	1.25	1.1	1.5	1.25

For dual or multiple drives consider the actual load sharing.

Actual absorbed power **Pa** and Motor power **Pm**  $\times$  **SF**  $\leq$  **P**

Size  
Number of stages 2  
Ratio

**P** Mechanical power rating  
**P**

High speed shaft extension  
**L**: left **C**: right-angle  
**R**: right  
**T**: two shaft extensions

Low speed shaft extension  
**L**: left  
**R**: right  
**T**: two shaft extensions

Low speed shaft type  
**N**: normal solid shaft  
**D**: shrink disc hollow shaft  
**K**: keyway hollow shaft

## Reference Data

Program survey in introduction.

The service factors SFmin are empirical values based on AGMA specifications and our experience. They apply for "State of the art" designed driven machines and normal operating conditions. Refer to Hansen for special designed applications or special operating conditions.

**M H** . 2 -       -      



### Dimensional drawings

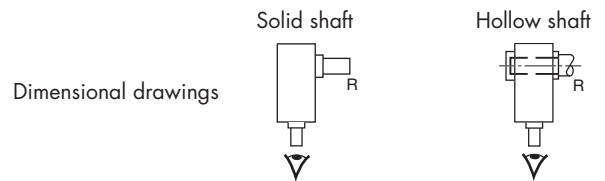

N : dimensional drawings: p. C1 & C3  
D : dimensional drawings: p. C2, C4 & C7  
K : dimensional drawings: p. C2, C4 & C8

# SELECTION - Thermal rating

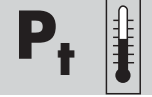

## Thermal check

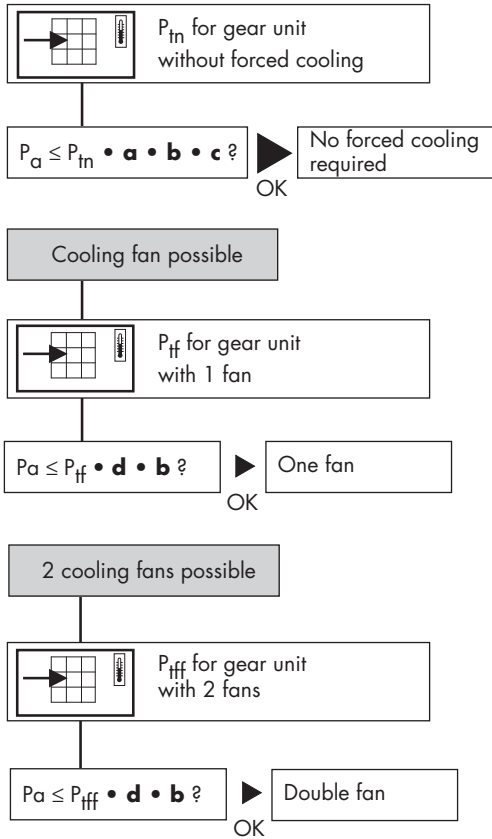

## Reference Data

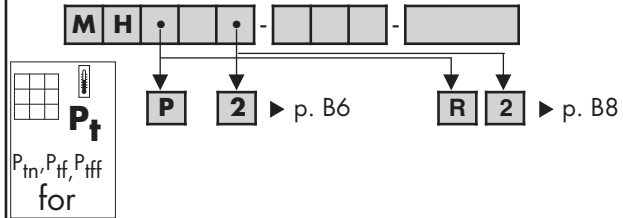

factor **a** for ambient temperature without fan

Reduction Ratio	Ambient temperature in °F				
	60 to 75		75 to 95		95 to 115
10 → 12.5	1	0.77		0.56	
14 → 20	1	0.80		0.62	
≥ 22.4	1	0.84	0.79	0.68	0.57
Size	C ▶ G	C ▶ E	F ▶ G	C ▶ E	F ▶ G

factor **b** for duration of service

h/year	h/day (max)				
	3		10		>16
1000	1.2	1.3	1.15	1.2	1.15
2000	-	-	1.1	1.1	1.1
≥ 4000	-	-	-	-	1
Size	C ▶ D	E ▶ G	C ▶ D	E ▶ G	C ▶ G

factor **c** for air circulation (without fan)

Mounting		
Indoors - small enclosure	0.68	0.62
Indoors - normal working area	1	1
Outdoors - protected against sun	1.38	1.43
Size	C ▶ E	F ▶ G

factor **d** for ambient temperature with fan

	Ambient temperature in °F			
	60 to 75	75 to 95	95 to 115	115 to 130
with fan	1	0.86	0.72	0.57

## Mining Conveyor drive $P_a = 85 \text{ hp}$ , $n_2 = 70 \text{ rpm}$ , Single drive

### Mechanical power rating

- Horizontal low speed shaft 2 H
- Right-angle shafts required 3 R
- application: see above
- load conditions: heavy duty 16h/24h
- prime mover: electric motor
- SF = 1.5 (page B2)
- $P_a \times SF = 85 \times 1.5 = 127.5 \text{ hp}$
- Ratio: 9 25

$$i = \frac{n_1}{n_2} = \frac{1750}{70} = 25$$

- Size and number of stages : 4 C  
mechanical power rating  $P = 135 \text{ hp}$  (page B6)  
check :  $P_a \times SF = 127.5 \text{ hp} \leq P = 135 \text{ hp}$   
dimensional drawings on page C4 5 2
- Right-angle shafts 6 C
- Machine shaft to the right 7 R
- Hollow shaft with shrink disc 8 D

1 M
2 H
3 R
4 C
5 2
- 6 C
7 R
8 D
- 9 25

### Thermal power rating (page B3)

#### First case

##### Operational parameters:

- . ambient temperature = 85°F :
- correction factor without fan : a = 0.84
- . operating time 16 h/day & > 4000 h/year : b = 1
- . mounted outdoors : c = 1.38

- Gear unit without fan:  $P_{Tn} = 83 \text{ hp}$  (p. B8)
- Check:  $85 \text{ hp} \leq ? 83 \text{ hp} \times 0.84 \times 1 \times 1.38 = 92.7 \text{ hp}$  : OK!
- No extra cooling is required.?

no extra cooling fan X

#### Second case

##### Operational parameters:

- . ambient temperature = 105°F :
- correction factor without fan : a = 0.68
- correction factor with fan : d = 0.72
- . operating time 16 h/day & > 4000 h/year : b = 1
- . mounted outdoors : c = 1.38

- Gear unit without fan:  $P_{Tn} = 83 \text{ hp}$  (p. B8)
- Check:  $P_a \leq ? P_{Tn} \times a \times b \times c$   
 $85 \text{ hp} \leq ? 83 \text{ hp} \times 0.68 \times 1 \times 1.38 = 77.9 \text{ hp}$  : not OK!
- Extra cooling is required.

- Cooling fan possible:  $P_{Tf} = 180 \text{ hp}$  (p. B8)
- Check:  $P_a \leq ? P_{Tf} \times d \times b$   
 $85 \text{ hp} \leq ? 180 \text{ hp} \times 0.72 \times 1 = 129.6 \text{ hp}$  : OK!
- Cooling fan solution can be selected.
- Dimensional drawing on page C4.

no extra cooling fan X

<b>M</b>	<b>H</b>	<b>P</b>	<b>C ▶ G</b>	<b>2</b>
<b>Gear unit</b>	<b>Horizontal L.S.S.</b>	<b>Parallel shafts</b>	<b>Size</b>	<b>Two stages</b>

**P (hp): Mechanical power ratings**      **T (1000 lbf.in): Torque ratings at low speed shaft**      **i<sub>ex</sub>: exact ratios**

		Gear unit size															
Nom. ratio <i>i<sub>N</sub></i>	Nom. speed rpm		C			D			E			F			G		
	<i>n</i> <sub>1</sub>	<i>n</i> <sub>2</sub>	P	T	Exact ratio <i>i<sub>ex</sub></i>	P	T	Exact ratio <i>i<sub>ex</sub></i>	P	T	Exact ratio <i>i<sub>ex</sub></i>	P	T	Exact ratio <i>i<sub>ex</sub></i>	P	T	Exact ratio <i>i<sub>ex</sub></i>
<b>10</b>	1750	175				470	166		690	244							
	1460	145				420	176		610	258							
	1160	115				350	185	9.800	520	275	9.823						
	870	87				270	191		390	277							
<b>11.2</b>	1750	155	295	121		430	173		610	249		920	364		1200	482	
	1460	130	250	122		360	174		510	250		810	380		1050	508	
	1160	105	200	123	11.381	290	175	11.170	410	252	11.275	660	391	10.944	860	534	11.376
	870	78	150	124		220	177		310	254		500	395		660	540	
<b>12.5</b>	1750	140	265	119		410	179		600	263		750	344		1100	499	
	1460	115	220	119		360	186		520	275		630	346		920	502	
	1160	93	180	120	12.349	290	191	12.170	420	277	12.198	510	348	12.650	740	505	12.635
	870	70	135	120		225	198		320	279		380	350		560	509	
<b>14</b>	1750	125	240	122		350	174		500	251		790	385		980	494	
	1460	105	200	123		290	175		420	252		670	392		850	513	
	1160	83	160	123	14.133	235	176	13.872	330	254	14.002	540	394	13.488	690	527	14.039
	870	62	120	124		175	178		250	255		410	397		530	542	
<b>16</b>	1750	110	215	119		340	189		500	276		620	346		890	502	
	1460	91	180	120		290	193		420	277		520	348		750	505	
	1160	73	145	121	15.336	235	198	15.365	330	278	15.401	410	349	15.592	600	508	15.593
	870	54	110	121		180	200		250	279		310	353		450	511	
<b>18</b>	1750	97	190	123		275	175		400	252		630	393		790	515	
	1460	81	160	123		235	176		330	253		530	394		670	527	
	1160	64	130	124	17.843	185	177	17.513	265	255	17.678	420	397	17.316	550	542	18.155
	870	48	96	124		140	178		200	256		320	398		420	546	
<b>20</b>	1750	88	170	120		275	196		400	277		480	349		700	506	
	1460	73	145	120		235	198		330	278		400	350		580	508	
	1160	58	115	121	19.361	185	200	19.727	265	279	19.490	320	353	20.016	470	511	20.164
	870	44	87	121		140	201		200	282		245	353		350	515	
<b>22.4</b>	1750	78	155	124		215	176		310	254		510	395		640	529	
	1460	65	125	124		180	177		265	255		430	396		550	541	
	1160	52	100	124	22.539	145	178	22.485	210	256	22.373	340	398	21.536	440	546	22.857
	870	39	77	125		110	179		160	258		255	401		330	548	
<b>25</b>	1750	70	135	120		225	200		310	278		390	351		560	509	
	1460	58	115	121		190	200		255	280		330	351		470	511	
	1160	46	91	121	24.457	150	201	24.474	205	281	25.202	260	353	24.895	370	514	25.387
	870	35	69	122		115	202		155	284		195	355		280	517	
<b>28</b>	1750	63	120	124		175	178		245	255		400	398		530	540	
	1460	52	100	124		145	177		205	256		330	399		450	545	
	1160	41	81	125	28.421	120	178	27.895	165	257	28.930	265	401	27.848	360	548	28.195
	870	31	61	125		89	179		125	259		200	403		270	550	
<b>31.5</b>	1750	56	110	121		175	200		255	280		300	353		450	512	
	1460	46	91	121		145	200		210	281		255	354		380	514	
	1160	37	73	122	30.839	120	201	31.413	170	282	30.726	205	356	32.191	300	515	31.316
	870	27.5	55	122		89	202		125	284		155	356		230	520	
<b>35.5</b>	1750	49	98	124		140	178		200	257		320	399		430	546	
	1460	41	82	125		115	178		170	257		265	400		360	547	
	1160	33	66	125	35.100	92	179	35.804	135	259	35.270	215	403	34.791	285	549	35.268
	870	24.5	50	126		69	180		100	259		160	405		215	554	
<b>40</b>	1750	44	88	121								245	353		360	514	
	1460	37	74	122	38.086							205	356		310	516	
	1160	29	59	122								165	357	40.217	245	519	39.171
	870	22	44	123								125	358		185	521	

M	H	P	C ▶ G
Gear unit	Horizontal L.S.S.	Parallel shafts	Size

2
Two stages

**Pt (hp) : Thermal power ratings (\*)**



: Number of fans. Correction factors - see p. B3

Nom. ratio <b>iN</b>	Nom. speed <b>n1</b> rpm		Gear unit size					
			<b>C</b>	<b>D</b>	<b>E</b>	<b>F</b>	<b>G</b>	
			hp	hp	hp	hp	hp	
<b>10</b>	1750	-		120				
		1	295	350				
	1460	-		140	150			
		1	280	340				
	1160	-		155	180			
		1	255	320				
	870	-		155	190			
		1	225	285				
<b>11.2</b>	1750	-	110	120				
		1	210	285	350	470	490	
	1460	-	115	135	150			
		1	195	270	340	460	510	
	1160	-	120	150	180	210	220	
		1	175	245	310	440	500	
	870	-	120	150	190	240	275	
		1	155	215	280	400	470	
	<b>12.5</b>	1750	-	110	130			
			1	215	285	350	460	500
		1460	-	120	145	160		
			1	200	265	330	460	510
1160		-	125	150	180	210	220	
		1	180	240	300	430	500	
870		-	120	150	180	235	275	
		1	160	210	265	390	460	
<b>14</b>		1750	-	110	125	135		
			1	200	275	340	470	540
		1460	-	115	140	160	185	
			1	185	255	320	460	530
	1160	-	115	140	175	220	250	
		1	165	230	295	420	510	
	870	-	110	140	180	235	280	
		1	140	200	265	370	460	
	<b>16</b>	1750	-	115	135	150		
			1	200	265	330	470	530
		1460	-	115	140	165	185	
			1	185	245	310	450	530
1160		-	115	140	170	215	250	
		1	170	220	280	410	500	
870		-	110	135	170	230	280	
		1	145	185	245	360	450	
<b>18</b>		1750	-	105	125	150	170	
			1	185	255	330	460	540
		1460	-	110	130	160	200	225
			1	170	235	300	430	520
	1160	-	105	135	175	220	255	
		1	150	210	275	390	480	
	870	-	99	130	170	225	270	
		1	130	180	240	340	420	
	<b>20</b>	1750	-	110	135	155	170	
			1	185	250	320	450	540
		1460	-	110	140	165	200	220
			1	170	235	290	420	510
1160		-	105	135	170	215	255	
		1	150	205	265	380	470	
870		-	100	125	160	220	265	
		1	130	175	225	340	410	

Nom. ratio <b>iN</b>	Nom. speed <b>n1</b> rpm		Gear unit size					
			<b>C</b>	<b>D</b>	<b>E</b>	<b>F</b>	<b>G</b>	
			hp	hp	hp	hp	hp	
<b>22.4</b>	1750	-	105	130	155	190	200	
		1	175	245	310	450	520	
	1460	-	105	130	165	210	235	
		1	160	220	290	420	490	
	1160	-	99	125	165	215	250	
		1	140	195	260	370	440	
	870	-	93	120	160	215	255	
		1	120	165	220	320	390	
<b>25</b>	1750	-	105	120	150	190	200	
		1	175	220	285	440	520	
	1460	-	105	120	155	205	230	
		1	160	200	260	410	480	
	1160	-	100	115	150	215	245	
		1	140	175	230	370	430	
	870	-	94	110	140	210	250	
		1	120	150	195	320	380	
	<b>28</b>	1750	-	97	120	150	185	210
			1	155	210	280	410	490
		1460	-	94	115	150	195	230
			1	140	190	255	370	460
1160		-	89	110	150	200	235	
		1	125	170	225	330	410	
870		-	82	105	140	190	235	
		1	105	140	195	280	350	
<b>31.5</b>		1750	-	97	110	145	180	210
			1	160	200	270	400	490
		1460	-	95	110	145	195	225
			1	145	180	245	370	450
	1160	-	90	105	140	195	240	
		1	125	155	215	320	410	
	870	-	83	97	130	185	235	
		1	105	130	180	275	350	
	<b>35.5</b>	1750	-	84	105	145	175	200
			1	135	190	265	360	440
		1460	-	80	105	140	180	210
			1	120	170	240	330	400
1160		-	76	99	140	175	215	
		1	105	150	210	290	360	
870		-	71	93	130	165	205	
		1	91	125	175	245	310	
<b>40</b>		1750	-	84			175	200
			1	135			350	430
		1460	-	82			175	215
			1	125			320	400
	1160	-	78			170	215	
		1	105			280	350	
	870	-	71			160	205	
		1	91			240	300	

(\*) Thermal ratings are valid for standard tilting angle up to 3°. For larger tilting angles: refer to Hansen

<b>M</b>	<b>H</b>	<b>R</b>	<b>C ▶ G</b>	<b>2</b>
<b>Gear unit</b>	<b>Horizontal L.S.S.</b>	<b>Right-angle shafts</b>	<b>Size</b>	<b>Two stages</b>

**P (hp): Mechanical power ratings**      **T (1000 lbf.in): Torque ratings at low speed shaft**      **i<sub>ex</sub>: exact ratios**

		Gear unit size															
Nom. ratio <i>i<sub>N</sub></i>	Nom. speed rpm		C			D			E			F			G		
	<i>n</i> <sub>1</sub>	<i>n</i> <sub>2</sub>	P	T	Exact ratio <i>i<sub>ex</sub></i>	P	T	Exact ratio <i>i<sub>ex</sub></i>	P	T	Exact ratio <i>i<sub>ex</sub></i>	P	T	Exact ratio <i>i<sub>ex</sub></i>	P	T	Exact ratio <i>i<sub>ex</sub></i>
			hp	1000 lbf.in		hp	1000 lbf.in		hp	1000 lbf.in		hp	1000 lbf.in		hp	1000 lbf.in	
<b>10</b>	1750	175				420	150		660	234							
	1460	145				370	159		580	248							
	1160	115				295	159	9.864	490	263	9.886						
	870	87				225	160		370	263							
<b>11.2</b>	1750	155	275	113		420	169		610	249		810	317		1150	470	
	1460	130	230	113		360	174		510	251		710	335		1000	496	
	1160	105	185	114	11.314	285	175	11.242	410	252	11.348	600	359	10.924	870	532	11.310
	870	78	140	113		215	177		310	254		480	378		660	540	
<b>12.5</b>	1750	140	270	118		380	172		560	252		760	344		1100	499	
	1460	115	225	119		330	178		500	267		630	345		920	501	
	1160	93	180	120	12.277	270	183	12.400	410	275	12.429	510	348	12.628	740	505	12.561
	870	70	135	120		210	189		310	279		380	350		560	508	
<b>14</b>	1750	125	230	120		340	174		490	251		740	366		1000	533	
	1460	105	195	120		285	175		410	252		630	374		850	536	
	1160	83	155	121	14.400	230	176	14.133	330	253	14.267	510	384	13.733	680	539	14.610
	870	62	115	120		175	177		245	255		400	397		510	543	
<b>16</b>	1750	110	210	119		320	176		470	266		610	346		860	503	
	1460	91	175	119		270	180		400	270		510	348		720	506	
	1160	73	140	121	15.625	220	185	15.318	320	270	15.718	410	350	15.875	580	508	16.227
	870	54	105	121		170	186		235	270		310	353		440	512	
<b>18</b>	1750	97	190	122		280	175		390	252		600	370		810	525	
	1460	81	160	123		235	176		330	254		510	378		690	539	
	1160	64	125	124	18.000	185	177	17.459	260	255	18.043	420	389	17.167	550	542	18.045
	870	48	96	125		140	178		195	257		320	398		420	546	
<b>20</b>	1750	88	170	120		235	166		340	241		490	348		700	506	
	1460	73	140	120		195	166		290	242		410	350		590	508	
	1160	58	115	121	19.531	155	166	19.486	230	242	19.471	330	352	19.844	470	511	20.042
	870	44	86	121		120	166		170	242		245	354		350	513	
<b>22.4</b>	1750	78	140	116		220	176		310	253		480	375		630	514	
	1460	65	120	116		185	177		265	255		410	383		530	525	
	1160	52	95	116	22.629	145	178	22.210	210	255	22.351	340	395	21.516	440	540	22.768
	870	39	71	116		110	179		160	258		255	401		330	548	
<b>25</b>	1750	70	135	121		165	148		245	218		390	350		560	509	
	1460	58	115	121		140	148		205	218		330	352		470	512	
	1160	46	91	121	24.554	110	148	24.800	160	217	24.857	260	353	24.871	370	513	25.288
	870	35	68	122		83	148		120	218		195	355		285	518	
<b>28</b>	1750	63	110	114		165	169		245	251		380	372		490	503	
	1460	52	92	114		140	168		205	251		320	381		420	514	
	1160	41	73	114	28.800	110	169	28.267	160	249	28.533	255	384	27.467	340	528	28.571
	870	31	55	114		83	169		120	250		195	384		265	546	
<b>31.5</b>	1750	56	105	121								310	352		450	511	
	1460	46	90	121								260	354		380	514	
	1160	37	72	122	31.250							205	356	31.750	300	515	31.733
	870	27.5	54	122								155	357		225	517	

<b>M</b>	<b>H</b>	<b>R</b>	<b>C ▶ G</b>	<b>2</b>
<b>Gear unit</b>	<b>Horizontal L.S.S.</b>	<b>Right-angle shafts</b>	<b>Size</b>	<b>Two stages</b>

**Pt (hp): Thermal power ratings (\*)**



: Number of fans. Correction factors - see p. B3

Nom. ratio <b>i<sub>N</sub></b>	Nom. speed <b>n<sub>1</sub></b> rpm		Gear unit size					
			<b>C</b>	<b>D</b>	<b>E</b>	<b>F</b>	<b>G</b>	
			hp	hp	hp	hp	hp	
<b>10</b>	1750	-		105				
		1		320	380			
	1460	-		130				
		1		300	360			
	1160	-		145	165			
	1		270	330				
	870	-		145	180			
	1		230	290				
<b>11.2</b>	1750	-	97	105				
		1	220	310	370	430	620	
	1460	-	105	125	130			
		1	205	285	360	430	620	
	1160	-	110	135	160	190		
	1	180	255	330	410	580		
	870	-	110	145	175	220	280	
	1	155	220	285	360	520		
<b>12.5</b>	1750	-	99	110				
		1	220	300	360	430	620	
	1460	-	105	125	135			
		1	205	280	340	420	610	
	1160	-	110	135	160	190	220	
	1	180	245	310	400	580		
	870	-	110	140	170	215	275	
	1	155	210	270	350	510		
<b>14</b>	1750	-	93	105				
		1	200	285	360	420	610	
	1460	-	99	120	135			
		1	185	265	340	410	600	
	1160	-	105	130	155	190	230	
	1	165	235	310	390	550		
	870	-	99	135	170	215	270	
	1	140	205	265	340	490		
<b>16</b>	1750	-	94	110				
		1	205	275	330	420	600	
	1460	-	105	120	140	135		
		1	185	250	310	410	590	
	1160	-	105	130	150	185	225	
	1	165	225	275	380	540		
	870	-	100	125	155	210	265	
	1	140	190	240	340	480		
<b>18</b>	1750	-	89	105	115			
		1	185	265	330	410	600	
	1460	-	94	115	135	160	185	
		1	170	240	310	390	570	
	1160	-	95	125	150	190	235	
	1	150	215	275	360	510		
	870	-	90	120	155	200	255	
	1	125	180	235	310	440		

Nom. ratio <b>i<sub>N</sub></b>	Nom. speed <b>n<sub>1</sub></b> rpm		Gear unit size					
			<b>C</b>	<b>D</b>	<b>E</b>	<b>F</b>	<b>G</b>	
			hp	hp	hp	hp	hp	
<b>20</b>	1750	-	91	105	120			
		1	185	240	300	410	590	
	1460	-	95	110	130	160	185	
		1	170	215	275	380	560	
	1160	-	95	110	140	185	235	
	1	150	190	245	350	500		
	870	-	91	105	135	200	250	
	1	125	160	210	310	440		
<b>22.4</b>	1750	-	82	100	115	140	160	
		1	160	230	295	380	560	
	1460	-	83	105	135	160	200	
		1	145	210	275	350	520	
	1160	-	82	105	135	175	225	
	1	125	180	245	320	460		
	870	-	78	100	135	180	235	
	1	105	150	205	270	390		
<b>25</b>	1750	-	83	94	105	135	160	
		1	160	205	255	370	550	
	1460	-	84	97	115	160	200	
		1	145	185	235	350	510	
	1160	-	83	94	120	175	225	
	1	130	160	205	310	450		
	870	-	78	90	115	175	235	
	1	105	135	170	265	390		
<b>28</b>	1750	-	71	91	110	140	170	
		1	135	195	250	340	500	
	1460	-	71	93	115	150	195	
		1	125	175	230	310	460	
	1160	-	70	91	115	160	210	
	1	105	155	200	275	400		
	870	-	66	87	110	155	210	
	1	89	130	170	230	340		
<b>31.5</b>	1750	-	72			135	170	
		1	140			330	490	
	1460	-	72			155	190	
		1	125			310	450	
	1160	-	70			155	210	
	1	105			270	400		
	870	-	66			155	205	
	1	89			225	330		

(\*) Thermal ratings are valid for standard tilting angle up to 3°. For larger tilting angles: refer to Hansen

<b>M</b>	<b>H</b>	<b>P / R</b>	<b>C ▶ G</b>	<b>2</b>
<b>Gear unit</b>	<b>Horizontal L.S.S.</b>	<b>Parallel / right-angle shafts</b>	<b>Size</b>	<b>Two stages</b>

Permissible radial overhung load on solid low speed shaft  $F_{rN}$ **lbf**

Shaft arrangements RL / LR / TL / CL / CR						
Direction of pull	$n_2$ (rpm)	Gear unit size				
		<b>C</b>	<b>D</b>	<b>E</b>	<b>F</b>	<b>G</b>
<b>45° up</b>	<b>200</b>	8400	13500	12500	18000	21500
	<b>150</b>	8400	13500	13500	19000	23000
	<b>100</b>	8400	13500	15000	20500	25500
	<b>≤ 50</b>	8400	13500	19500	25500	30500
<b>Horizontal</b>	<b>200</b>	17500	16500	13500	19500	21500
	<b>150</b>	18000	17500	14500	20500	23000
	<b>100</b>	19500	18500	16000	22500	25500
	<b>≤ 50</b>	24000	23500	20500	23000	30500
<b>45° down</b>	<b>200</b>	12000	15000	12500	18000	21500
	<b>150</b>	12000	16000	13500	19000	23000
	<b>100</b>	12000	17500	15000	20500	25500
	<b>≤ 50</b>	12000	20000	19500	25500	30500

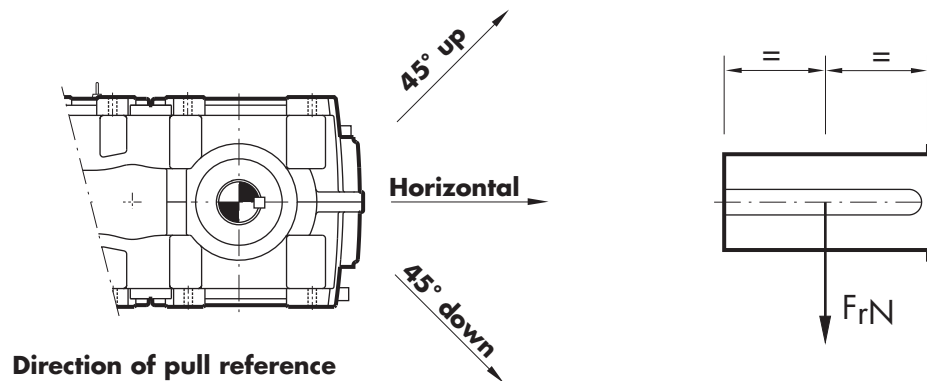

Direction of pull reference

The values in the tables can be applied for radial overhung loads acting between the collar and the middle of the shaft extension.

When different or more exact conditions are available, other values may be applicable - refer to Hansen.



## Moments of inertia $WR^2$ in lb.in<sup>2</sup>

### Parallel shafts

**P**

$i_N$	Gear unit size				
	<b>C</b>	<b>D</b>	<b>E</b>	<b>F</b>	<b>G</b>
<b>10</b>		265	510		
<b>11.2</b>	125	240	470	920	1750
<b>12.5</b>	115	190	370	830	1600
<b>14</b>	90	175	340	680	1300
<b>16</b>	84	135	270	620	1200
<b>18</b>	64	125	250	490	930
<b>20</b>	60	98	200	450	880
<b>22.4</b>	47	91	185	370	700
<b>25</b>	45	74	145	350	670
<b>28</b>	35	70	140	270	550
<b>31.5</b>	34	56	115	260	530
<b>35.5</b>	27.5	53	110	210	430
<b>40</b>	27			205	420

### Right-angle shafts

**R**

$i_N$	Gear unit size				
	<b>C</b>	<b>D</b>	<b>E</b>	<b>F</b>	<b>G</b>
<b>10</b>		270	540		
<b>11.2</b>	130	245	490	900	1700
<b>12.5</b>	125	195	380	810	1550
<b>14</b>	94	180	350	710	1200
<b>16</b>	89	135	245	650	1150
<b>18</b>	69	125	230	450	800
<b>20</b>	66	90	175	410	750
<b>22.4</b>	50	84	160	290	520
<b>25</b>	48	66	125	270	490
<b>28</b>	38	62	120	205	370
<b>31.5</b>	37			190	350

$i_N$ : nominal ratio

The moment of inertia  $WR^2$  of the gear unit components relate to the high speed shaft.

# ARRANGEMENTS WITH MOTORS

## Horizontal low speed shaft

### Lantern housings

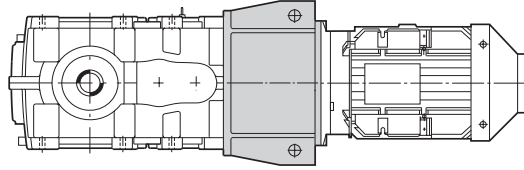

Dimensions of pilot  
see page C6

### Scoops

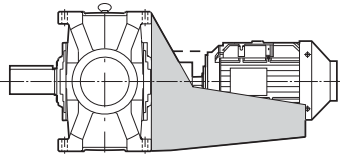

**M5**

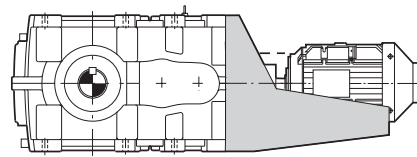

**M8**

### Adjustable motor platforms

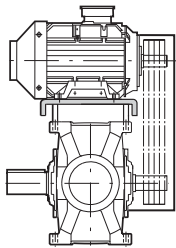

**M1**

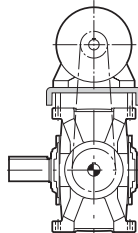

**M3**

### Motor bases

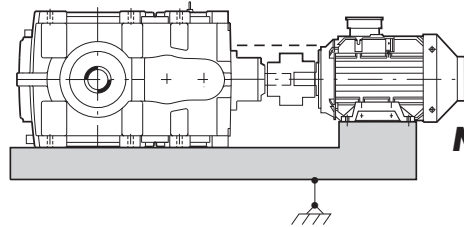

**M7**

### Bed plates

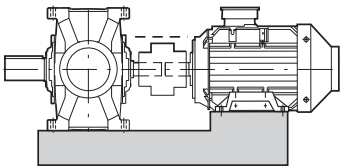

**M10**

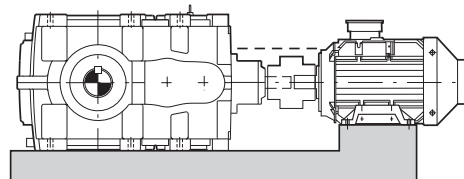

**M12**

<b>MHPC ▶ G2 - ..N</b>	<b>Solid shaft</b>	C1
<b>MHPC ▶ G2 - ..D/K</b>	<b>hollow shaft</b>	C2
<b>MHRC ▶ G2 - ..N</b>	<b>solid shaft</b>	C3
<b>MHRC ▶ G2 - ..D/K</b>	<b>hollow shaft</b>	C4
<b>Tunnel drive execution</b>		C5
<b>Pilot dimensions for lantern housing</b>		C6
<b>Hollow low speed shaft - shrink disc connection</b>		C7
	<b>- keyed connection</b>	C8
<b>Backstops</b>		C9

<b>M</b>	<b>H</b>	<b>P</b>	<b>C ▶ G</b>	<b>2</b>
Gear unit	Horizontal L.S.S.	Parallel shafts	Size	Two stages

97MU-HP20001Z A  
inch

Normal solid shaft ..N

The user is responsible for the provision of **safety guards** and correct installation of all equipment.

Certified dimensions upon request.

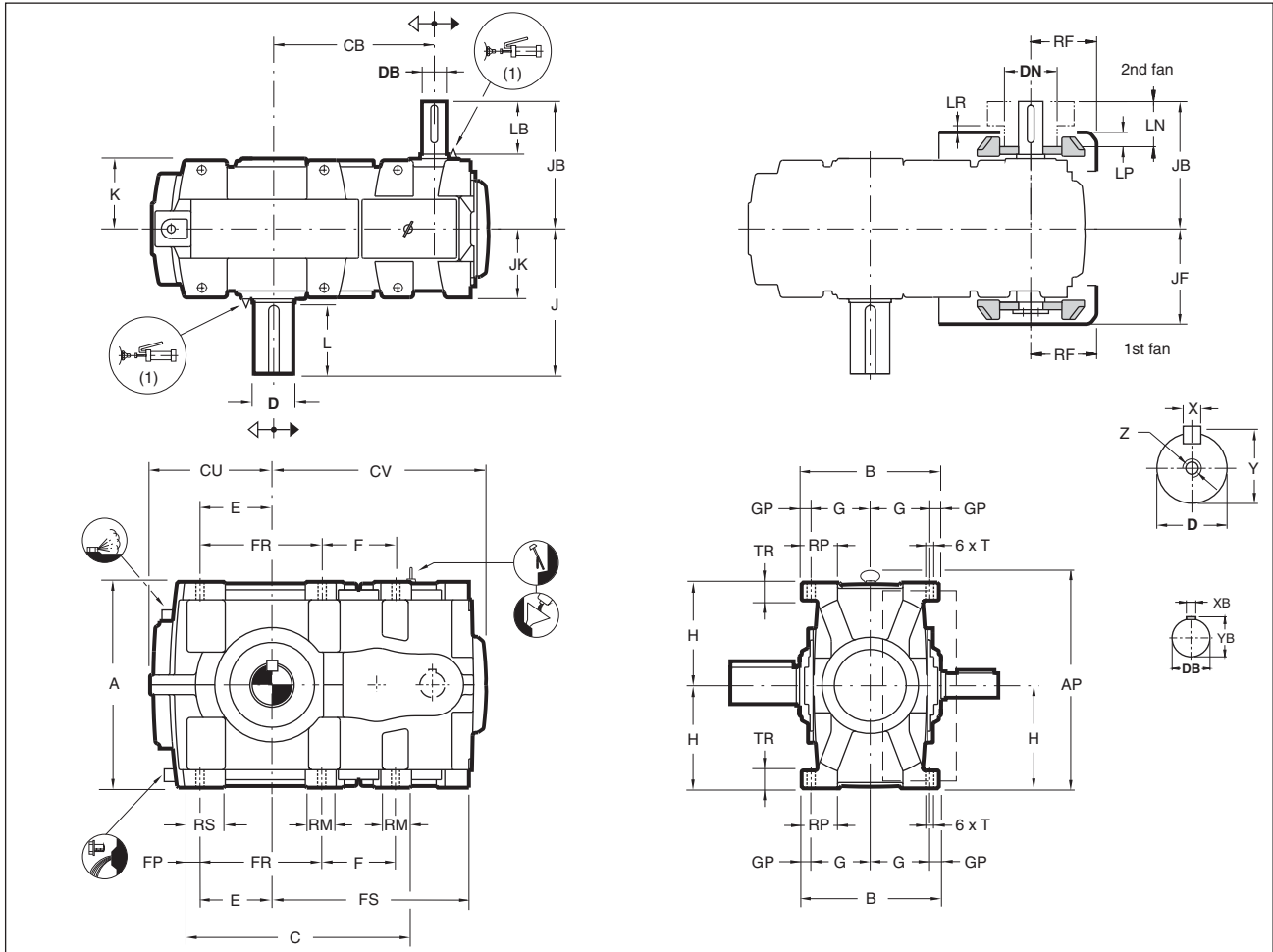

1 = standard shaft extension  
2 = additional shaft extension

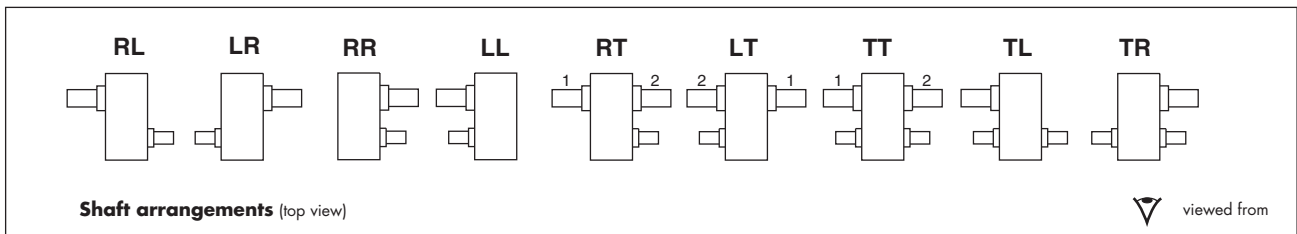

(1) Grease lubrication point

(2) Shaft tolerances:  
1.500" Ø or less  
+ .0000  
- .0005

over 1.500" Ø  
+ .000  
- .001

Keys in shaft extensions as per USAS B17.1.-1967. Shafts are always supplied with keys attached.

Type	A	AP	B	C	CB	CU	CV	E	F	FP	FR	FS	G	GP	H	J	JB	JK	K	RM	RP	RS	T	TR	Weight lb	Oil US gal
MHPC2	19.69	20.96	13.39	22.28	15.079	11.81	20.51	7.09	7.48	1.66	11.81	19.01	5.51	1.18	9.84	15.55	11.34	6.69	6.69	2.93	3.24	3.52	0.91	1.77	1134	5
MHPD2	22.05	23.38	14.96	24.27	17.047	12.99	22.56	7.68	7.87	2.05	13.19	20.93	6.30	1.18	11.02	18.11	12.01	7.48	7.47	3.26	3.74	4.30	0.91	1.97	1591	7.9
MHPE2	24.80	26.14	16.54	26.77	19.331	14.59	25.47	8.66	8.86	2.79	14.76	23.72	7.09	1.18	12.40	18.90	14.17	8.27	8.27	3.83	4.72	5.03	1.06	2.17	2046	10
MHPF2	27.95	29.32	18.50	31.48	22.362	16.93	29.53	10.04	10.24	3.04	16.73	27.49	8.07	1.18	13.98	21.65	15.16	9.26	9.25	4.25	4.53	5.28	1.06	2.36	2611	14.5
MHPG2	31.50	32.92	21.65	35.58	25.394	19.69	33.39	11.73	11.22	3.27	19.69	30.91	9.45	1.38	15.75	23.03	16.34	10.83	10.83	5.11	5.12	5.82	1.30	2.56	3636	19.8

Type	Shafts (2)									Fan						
	D	L	X	Y	Z	UNC	DB	LB	XB	YB	DN max	LN	LP	LR min	RF	JF
MHPC2	4.625	8.27	1.25	5.164	1/2 - 13		1.625	4.33	0.375	1.791	5.72	2.18	0.30	0.79	6.30	9.44
MHPD2	5.000	9.84	1.25	5.546	1/2 - 13		1.875	4.33	0.500	2.091	7.08	2.44	1.46	0.79	8.07	11.00
MHPE2	5.500	9.84	1.25	6.053	1/2 - 13		2.250	5.51	0.500	2.472	7.08	3.66	1.50	0.79	8.27	12.00
MHPF2	6.250	11.81	1.50	6.909	1/2 - 13		2.500	5.51	0.625	2.773	9.62	3.42	2.60	1.18	10.62	14.33
MHPG2	7.000	11.81	1.75	7.639	1/2 - 13		2.875	5.51	0.750	3.200	9.62	3.38	2.60	1.18	10.62	15.55

<b>M</b>	<b>H</b>	<b>P</b>	<b>C ▶ G</b>	<b>2</b>
Gear unit	Horizontal L.S.S.	Parallel shafts	Size	Two stages

Shrink disc hollow shaft

..D

Keyway hollow shaft

..K

The user is responsible for the provision of **safety guards** and correct installation of all equipment.

Certified dimensions upon request.

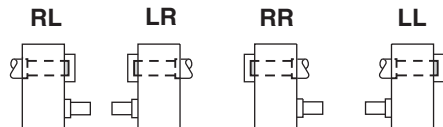
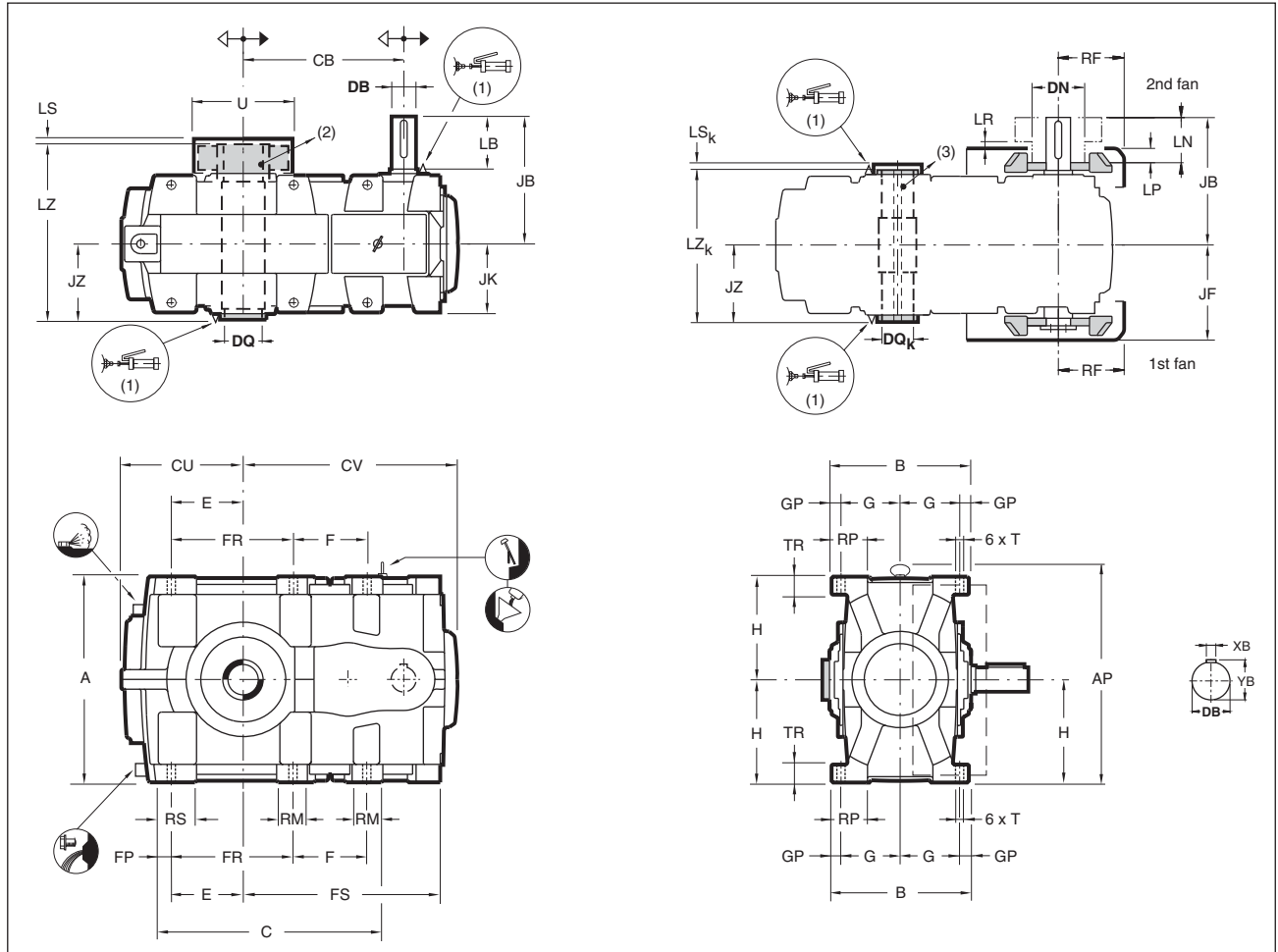

Shaft arrangements (top view)

viewed from

(1) Grease lubrication point  
(4) Shaft tolerances :  
1.500" Ø or less  
+ .0000  
- .0005

over 1.500" Ø  
+ .000  
- .001

(5) Keys in shaft extensions as per USAS B17.1.-1967. Shafts are always supplied with keys attached.

\* Please refer to page C7 + C8 for detailed information

Type	A	AP	B	C	CB	CU	CV	E	F	FP	FR	FS	G	GP	H	JB	JK	JZ	RM	RP	RS	T	TR	Weight lb	Oil US gal
MHPC2	19.69	20.96	13.39	22.28	15.079	11.81	20.51	7.09	7.48	1.66	11.81	19.01	5.51	1.18	9.84	11.34	6.69	7.28	2.93	3.24	3.52	0.91	1.77	1134	5.00
MHPD2	22.05	23.38	14.96	24.27	17.047	12.99	22.56	7.68	7.87	2.05	13.19	20.93	6.30	1.18	11.02	12.01	7.48	8.27	3.26	3.74	4.30	0.91	1.97	1591	7.90
MHPE2	24.80	26.14	16.54	26.77	19.331	14.69	25.47	8.66	8.86	2.79	14.76	23.72	7.09	1.18	12.40	14.17	8.27	9.06	3.83	4.72	5.03	1.06	2.17	2046	10.00
MHPF2	27.95	29.32	18.50	31.48	22.362	16.93	29.53	10.04	10.24	3.04	16.73	27.49	8.07	1.18	13.98	15.16	9.26	9.84	4.25	4.53	5.28	1.06	2.36	2611	14.50
MHPG2	31.50	32.92	21.65	35.58	25.394	19.69	33.39	11.73	11.22	3.27	19.69	30.91	9.45	1.38	15.75	16.34	10.83	11.22	5.11	5.12	5.82	1.30	2.56	3636	19.80

Type	Shafts										Fan						
	Hollow low speed shaft										DN max	LN	LP	LR min	RF	JF	
	(2) Shrink disc					(3) Keyway											
DQ *	LS	LZ	U max	DQk	LSk	LZk	DB (4)	LB	XB (5)	YB (5)	DN max	LN	LP	LR min	RF	JF	
MHPC2	4.720	0.38	18.11	12.62	5.224	0.80	14.56	1.625	4.33	0.375	1.791	5.72	2.18	0.30	0.79	6.30	9.44
MHPD2	5.120	0.39	20.47	13.66	5.118	0.80	16.54	1.875	4.33	0.500	2.091	7.08	2.44	1.46	0.79	8.07	11.00
MHPE2	5.510	0.41	22.05	14.12	5.512	0.77	18.12	2.250	5.51	0.500	2.472	7.08	3.66	1.50	0.79	8.27	12.00
MHPF2	6.300	0.39	24.41	16.61	6.299	0.69	19.68	2.500	5.51	0.625	2.773	9.62	3.42	2.60	1.18	10.62	14.33
MHPG2	7.090	0.47	28.62	18.62	7.087	1.27	22.44	2.875	5.51	0.750	3.200	9.62	3.38	2.60	1.18	10.62	15.55

<b>M</b> Gear unit	<b>H</b> Horizontal L.S.S.	<b>R</b> Right-angle shafts	<b>C ▶ G</b> Size	<b>2</b> Two stages
-----------------------	-------------------------------	--------------------------------	----------------------	------------------------

Normal solid shaft for mining gear units

..N

The user is responsible for the provision of **safety guards** and correct installation of all equipment.

Certified dimensions upon request.

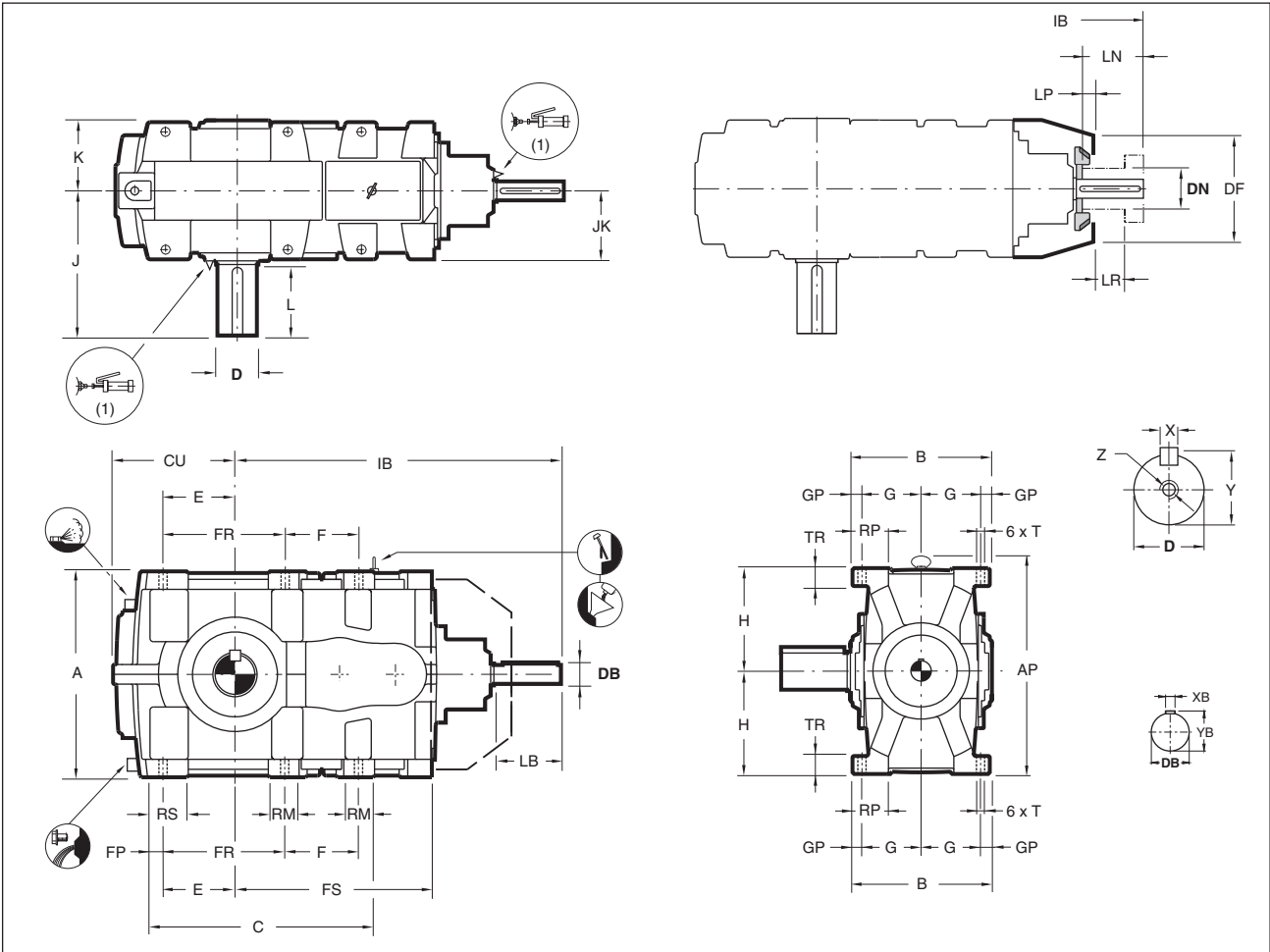

1 = standard shaft extension  
2 = additional shaft extension

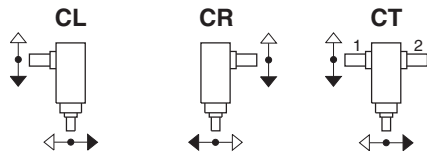

Shaft arrangements (top view)

viewed from

(1) Grease lubrication point

(2) Shaft tolerances :  
1.500" Ø or less  
+ .0000  
- .0005

over 1.500" Ø  
+ .000  
- .001

Type	A	AP	B	C	CU	E	F	FP	FR	FS	G	GP	H	IB	J	JK	K	RM	RP	RS	T	TR	Weight lb	Oil US gal
MHRC2	19.69	20.96	13.39	29.53	11.81	7.09	7.48	1.26	11.81	19.01	5.51	1.18	9.84	33.54	15.55	6.69	6.69	2.93	3.24	3.52	0.91	1.77	1134	5.3
MHRD2	22.05	23.38	14.96	30.87	12.99	7.68	7.87	2.24	13.19	20.93	6.30	1.18	11.02	35.43	18.11	7.48	7.48	3.26	3.74	4.30	0.91	1.97	1591	8.2
MHRE2	24.80	26.14	16.54	35.20	14.69	8.66	8.86	2.80	14.76	23.72	7.09	1.18	12.40	39.76	18.90	8.27	8.27	3.83	4.72	5.03	1.06	2.17	2046	10.6
MHRF2	27.95	29.32	18.50	42.72	16.93	10.04	10.24	4.29	16.73	27.49	8.07	1.18	13.98	44.13	21.65	9.26	9.25	4.25	4.53	5.28	1.06	2.36	2611	15.3
MHRG2	31.50	32.92	21.65	48.43	19.69	11.73	11.22	4.61	19.69	30.91	9.45	1.38	15.75	48.78	23.03	10.83	10.83	5.11	5.12	5.82	1.30	2.56	3636	21.1

Type	Shafts (2)									Fan				
	D	L	X	Y	Z UNC	DB	LB	XB	YB	DF	DN max	LN	LP	LR min
MHRC2	4.625	8.27	1.250	5.164	1/2 - 13	1.750	7.09	0.375	1.917	13.38	5.72	4.66	0.35	0.79
MHRD2	5.000	9.84	1.250	5.546	1/2 - 13	2.000	7.09	0.500	2.218	16.34	7.08	5.19	1.65	0.79
MHRE2	5.500	9.84	1.250	6.053	1/2 - 13	2.375	8.27	0.625	2.646	17.00	7.08	6.06	1.65	0.79
MHRF2	6.250	11.81	1.500	6.909	1/2 - 13	2.625	8.27	0.625	2.900	18.50	7.08	6.42	1.65	1.18
MHRG2	7.000	11.81	1.750	7.639	1/2 - 13	3.000	8.27	0.750	3.327	21.65	9.62	6.14	2.60	1.18

Keys in shaft extensions as per USAS B17.1-1967. Shafts are always supplied with keys attached.

<b>M</b> Gear unit	<b>H</b> Horizontal L.S.S.	<b>R</b> Right-angle shafts	<b>C ▶ G</b> Size	<b>2</b> Two stages
-----------------------	-------------------------------	--------------------------------	----------------------	------------------------

<b>Hollow shaft with shrink disc connection</b>	<b>..D</b>
<b>Hollow shaft with keyway</b>	<b>..K</b>

The user is responsible for the provision of **safety guards** and correct installation of all equipment.  
Certified dimensions upon request.

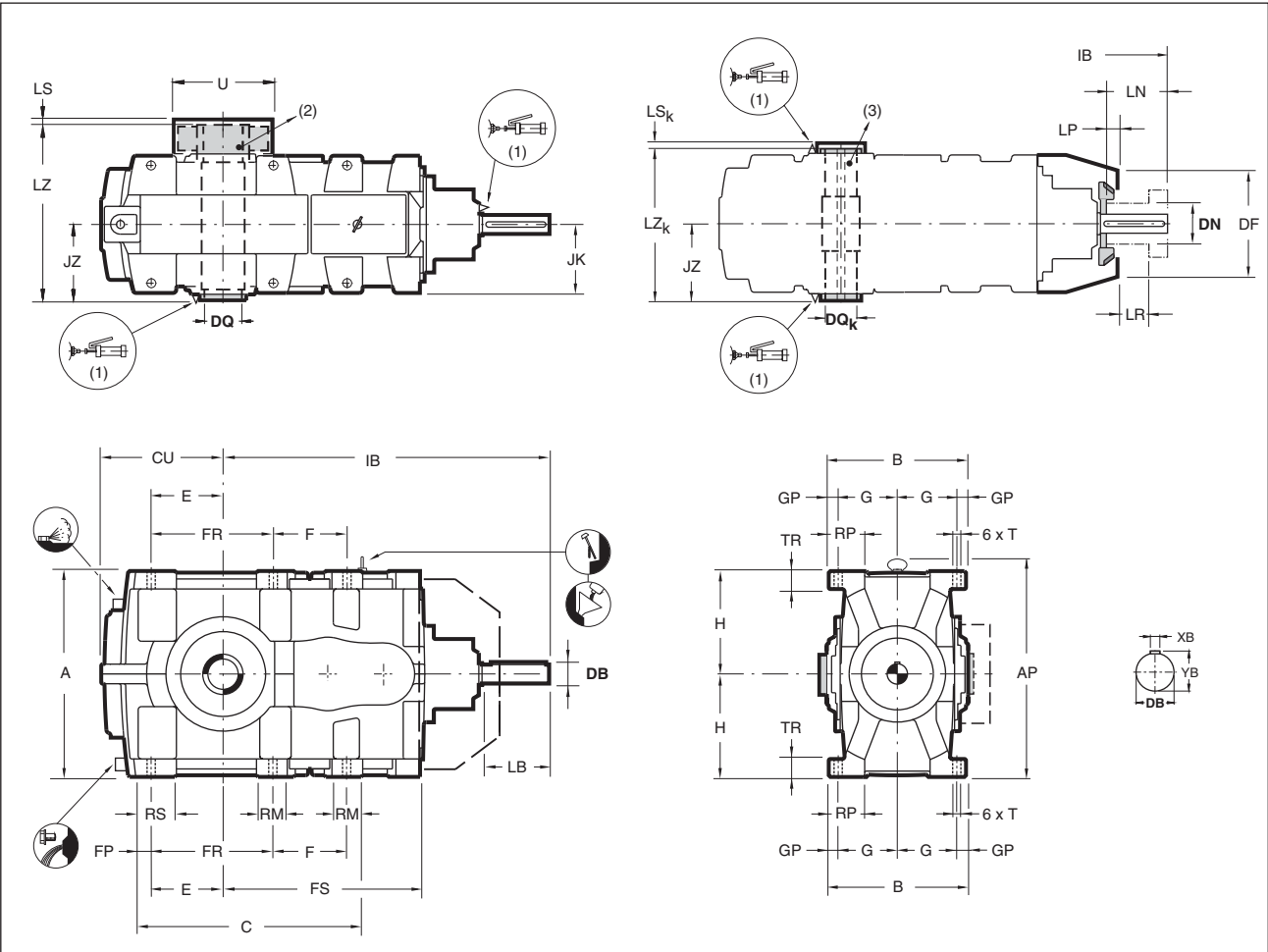

(1) Grease lubrication point, for hollow shaft on both sides of the gear unit

(4) Shaft tolerances:  
1.500" Ø or less  
+ .0000  
- .0005

over 1.500" Ø  
+ .000  
- .001

(5) Keys in shaft extensions as per USAS B17.1.-1967. Shafts are always supplied with keys attached.

\* Please refer to page C7 + C8 for detailed information

Type	A	AP	B	C	CU	E	F	FP	FR	FS	G	GP	H	IB	JK	JZ	RM	RP	RS	T	TR	Weight lb	Oil US gal
<b>MHRC2</b>	19.69	20.96	13.39	29.53	11.81	7.09	7.48	1.26	11.81	19.01	5.51	1.18	9.84	33.54	6.69	7.28	2.93	3.24	3.52	0.91	1.77	1134	5.3
<b>MHRD2</b>	22.05	23.38	14.96	30.87	12.99	7.68	7.87	2.24	13.19	20.93	6.30	1.18	11.02	35.43	7.48	8.27	3.26	3.74	4.30	0.91	1.97	1591	8.2
<b>MHRE2</b>	24.80	26.14	16.54	35.20	14.69	8.66	8.86	2.80	14.76	23.72	7.09	1.18	12.40	39.76	8.27	9.06	3.83	4.72	5.03	1.06	2.17	2046	10.6
<b>MHRF2</b>	27.95	29.32	18.50	42.72	16.93	10.04	10.24	4.29	16.73	27.49	8.07	1.18	13.98	44.13	9.26	9.84	4.25	4.53	5.28	1.06	2.36	2611	15.3
<b>MHRG2</b>	31.50	32.92	21.65	48.43	19.69	11.73	11.22	4.61	19.69	30.91	9.45	1.38	15.75	48.78	10.83	11.22	5.11	5.12	5.82	1.30	2.56	3636	21.1

Type	Shafts								Fan								
	Hollow low speed shaft								DB (4)	LB	XB (5)	YB (5)	DF	DN max	LN	LP	LR min
	(2) Shrink disc				(3) Keyway												
DQ *	LS	LZ	U max	DQk	LSk	LZk											
<b>MHRC2</b>	4.720	0.38	18.11	12.62	4.224	0.80	14.56	1.750	7.09	0.375	1.917	13.38	5.72	4.66	0.35	0.79	
<b>MHRD2</b>	5.120	0.39	20.47	13.66	5.118	0.80	16.54	2.000	7.09	0.500	2.218	16.34	7.08	5.19	1.65	0.79	
<b>MHRE2</b>	5.510	0.41	22.05	14.12	5.512	0.77	18.12	2.375	8.27	0.625	2.646	17.00	7.08	6.06	1.65	0.79	
<b>MHRF2</b>	6.300	0.39	24.41	16.61	6.299	0.69	19.68	2.625	8.27	0.625	2.900	18.50	7.08	6.42	1.65	1.18	
<b>MHRG2</b>	7.090	0.47	28.62	18.62	7.087	1.27	22.44	3.000	8.27	0.750	3.327	21.65	9.62	6.14	2.6	1.18	

# Tunnel drive execution

inch

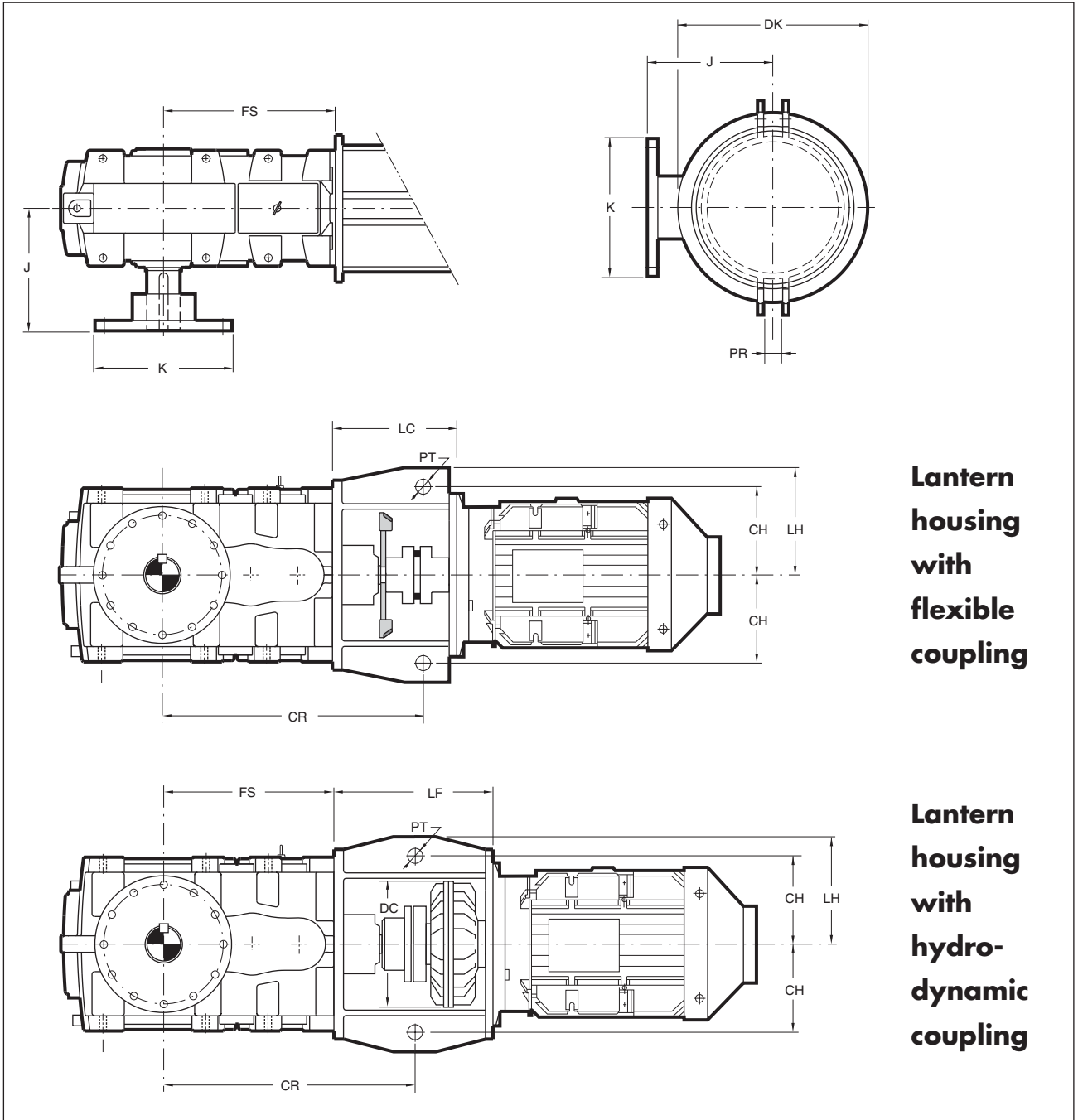

**Lantern housing with flexible coupling**

**Lantern housing with hydrodynamic coupling**

Type	CH	CR	DC max.	DK max.	FS	J	K	LC max.	LF max.	LH	PR	PT
<b>MHRC2</b>	15.35	33.54	23.46	26.38	19.01	15.55	15.75	23.27	34.61	17.48	2.36	1.57
<b>MHRD2</b>	17.13	35.43	25.91	31.50	20.93	18.11	17.72	23.94	32.09	19.53	2.76	1.77
<b>MHRE2</b>	20.67	39.88	31.73	37.01	23.72	18.90	19.69	26.73	39.76	23.35	2.95	1.97
<b>MHRF2</b>	23.03	44.13	34.57	39.37	27.49	21.65	22.44	27.17	43.70	26.50	3.94	2.56
<b>MHRG2</b>	23.62	48.78	35.12	40.16	30.91	23.03	25.20	29.02	44.65	27.36	4.13	2.76

**Note:** For customized lantern design contact Hansen



# PILOT FOR LANTERN HOUSING

inch

## Right-angle shaft gear unit

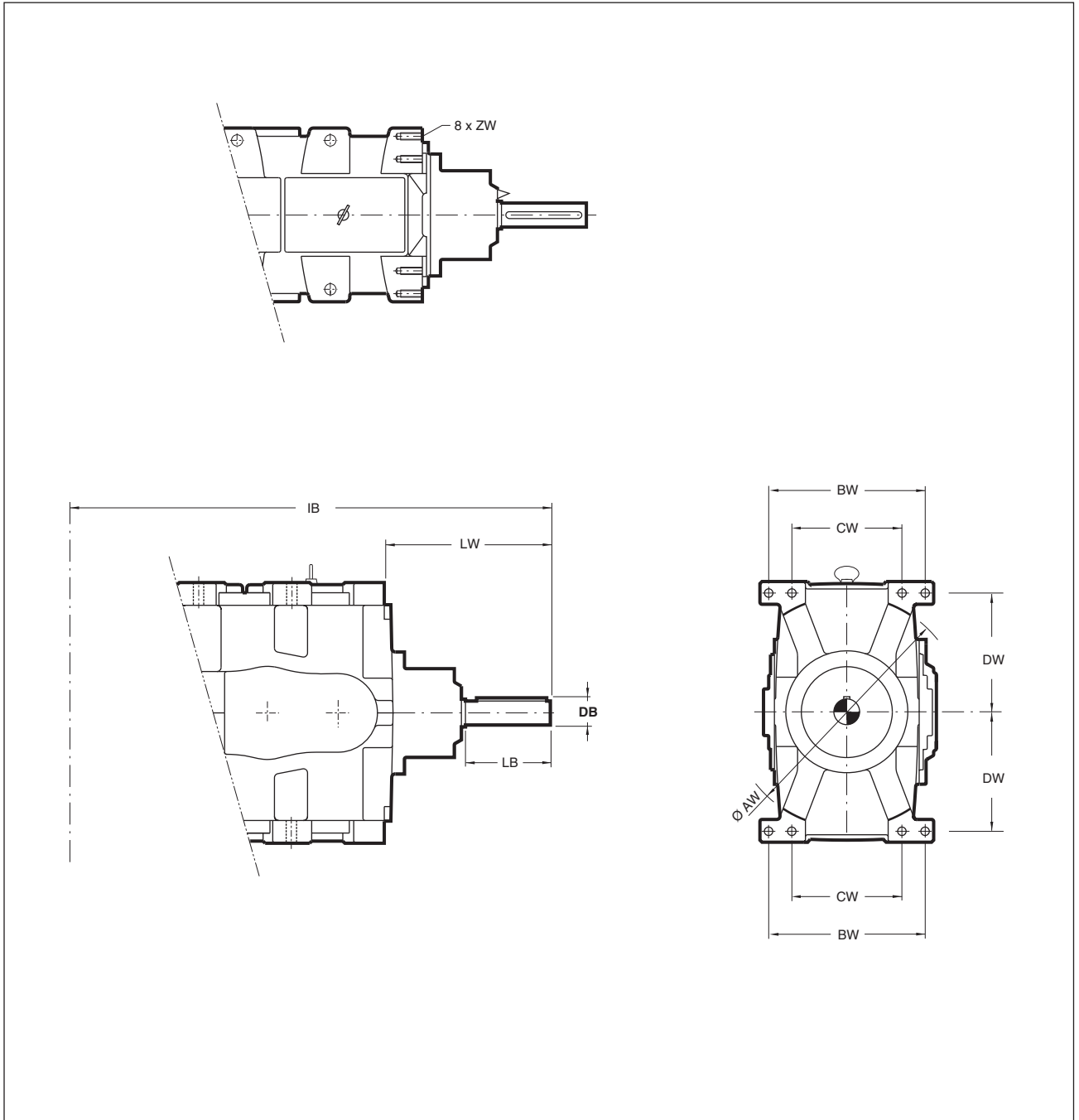

Type	Ø AW + .000 - .008	BW	CW	DW	ZW	LW	DB	LB	IB
MHRC2	17.322	11.968	8.346	8.858	M16 x 1.2	14.55	1.750	7.09	33.54
MHRD2	19.684	13.386	9.449	10.039	M20 x 1.6	14.48	2.000	7.09	35.43
MHRE2	22.040	14.566	10.236	11.220	M24 x 1.8	16.04	2.375	8.27	39.76
MHRF2	25.196	16.614	12.598	12.795	M24 x 1.8	16.64	2.625	8.27	44.13
MHRG2	28.740	19.292	14.566	14.488	M30 x 2.3	17.87	3.000	8.27	48.78

<b>M</b> Gear unit	<b>H</b> Horizontal L.S.S.	<b>P/R</b> Parallel / right-angle shafts	<b>C ▶ G</b> Size	<b>2</b> Gear sets
-----------------------	-------------------------------	---	----------------------	-----------------------

**Hollow low speed shaft - Shrink disc connection** **D**

**Hollow shaft**

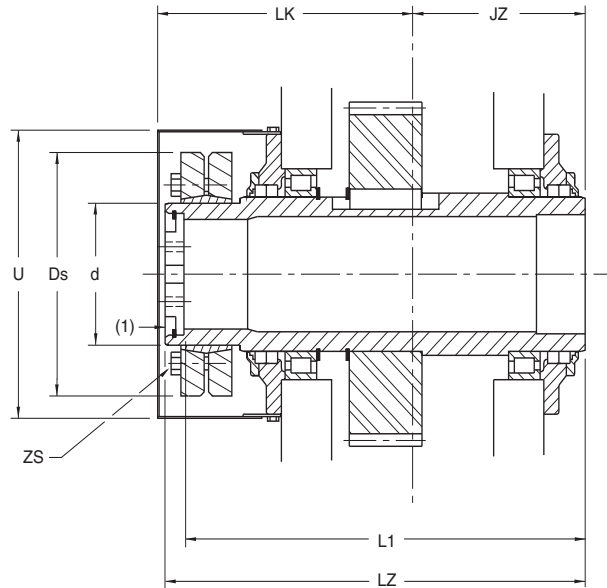

**Driven shaft**

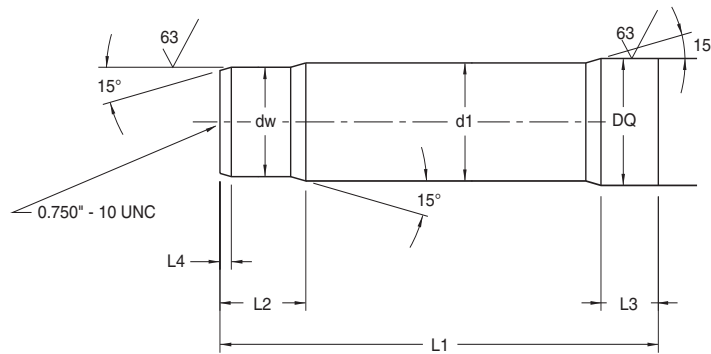

The user is responsible for the provision of **safety guards** and correct installation of all equipment.

Certified dimensions upon request.

(1) If a thrust load occurs, which is not taken up by the shoulder on the machine shaft, a thrust washer would need to be provided.

Type	Shrink disc					Hollow shaft			
	Type	d	Ds	ZS Screws	TA lbf.in	JZ	LK	LZ	U max
<b>MH.C2</b>	155 - 71	6.102	10.35	M12	885	7.28	11.22	18.11	12.62
<b>MH.D2</b>	165 - 71	6.496	11.42	M16	2124	8.27	12.60	20.47	13.66
<b>MH.E2</b>	175 - 71	6.890	11.81	M16	2124	9.06	13.39	22.05	14.12
<b>MH.F2</b>	195 - 71	7.677	13.78	M16	2124	9.84	14.96	24.41	16.61
<b>MH.G2</b>	210 - 71	9.449	15.94	M20	4160	11.22	17.80	28.62	18.62

Type	Driven shaft						
	dw	d1	DQ	L1	L2 min	L3	L4
<b>MH.C2</b>	4.5276 -0.0009	4.606	4.7230 -0.0009	17.32	3.15	2.76	0.20
<b>MH.D2</b>	4.9213 -0.0010	4.999	5.1164 -0.0010	19.57	3.35	2.76	0.24
<b>MH.E2</b>	5.3149 -0.0010	5.394	5.5101 -0.0010	21.10	3.54	2.76	0.24
<b>MH.F2</b>	6.1024 -0.0010	6.181	6.2975 -0.0010	23.39	4.33	3.54	0.24
<b>MH.G2</b>	7.0866 -0.0010	7.283	7.4783 -0.0011	27.36	5.90	3.74	0.24

<b>M</b> Gear unit	<b>H</b> Horizontal L.S.S.	<b>P/R</b> Parallel / right-angle shafts	<b>C ▶ G</b> Size	<b>2</b> Gear sets
-----------------------	-------------------------------	---	----------------------	-----------------------

**Hollow low speed shaft - Keyed connection** **K**

The user is responsible for the provision of **safety guards** and correct installation of all equipment.

Certified dimensions upon request.

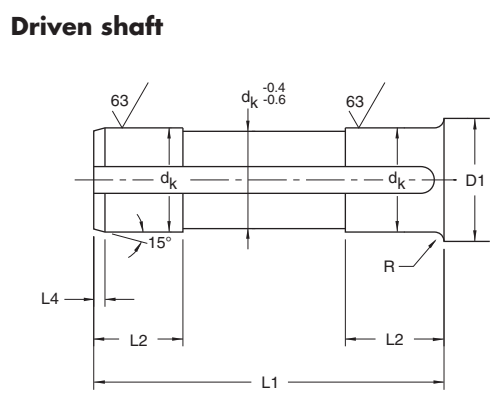
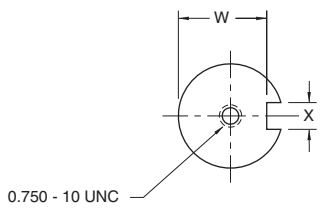
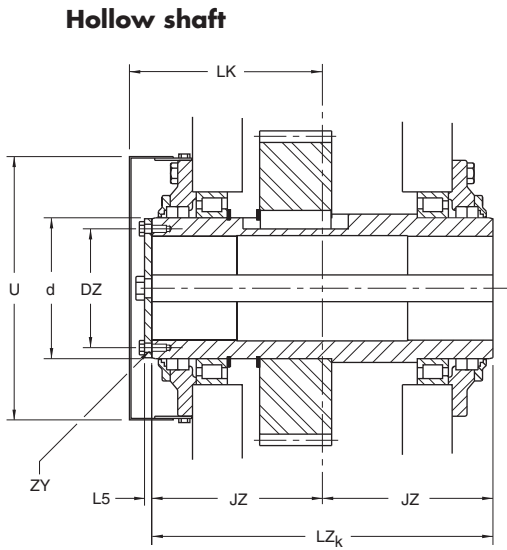
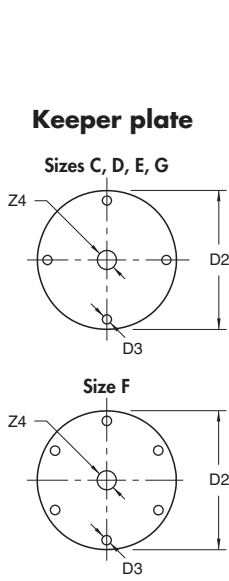

Type	Hollow shaft										
	d	D2	D3	DZ	JZ	LK	LZ <sub>k</sub>	L5	U <sub>max</sub>	ZY	Z4
<b>MH.C2</b>	6.693	6.62	0.53	5.590	7.28	8.46	14.56	0.38	12.62	M12 x 0.79	0.81
<b>MH.D2</b>	7.087	7.00	0.53	5.984	8.27	9.45	16.54	0.38	13.66	M12 x 0.79	0.81
<b>MH.E2</b>	7.480	7.38	0.53	6.377	9.06	10.24	18.12	0.35	14.12	M12 x 0.79	0.81
<b>MH.F2</b>	7.874	7.88	0.44	7.000	9.84	11.02	19.68	0.50	16.61	M10 x 0.79	0.81
<b>MH.G2</b>	9.843	9.75	0.69	8.334	11.22	12.99	22.44	0.50	18.62	M16 x 0.79	0.81

Type	Driven shaft								
	dk	D1 <sub>min</sub>	L1	L2	L4	R	X	W	
<b>MH.C2</b>	4.7244 -0.0009	5.12	14.49	4.13	0.20	0.10	1.260	4.299	
<b>MH.D2</b>	5.1181 -0.0010	5.51	16.46	4.13	0.25	0.10	1.260	4.693	
<b>MH.E2</b>	5.5118 -0.0010	6.10	18.03	4.72	0.25	0.10	1.417	5.039	
<b>MH.F2</b>	6.2992 -0.0010	6.69	19.61	5.31	0.25	0.10	1.575	5.787	
<b>MH.G2</b>	7.0866 -0.0010	7.68	22.36	6.10	0.25	0.10	1.772	6.496	

<b>M</b>	<b>H</b>	<b>P/R</b>	<b>C ▶ G</b>	<b>2</b>
Gear unit	Horizontal L.S.S.	Parallel / right-angle shafts	Size	Two stages

<b>Dimensions for backstop</b>	
Normal solid shaft	<b>..N</b>
Shrink disc hollow shaft	<b>..D</b>
Keyway hollow shaft	<b>..K</b>

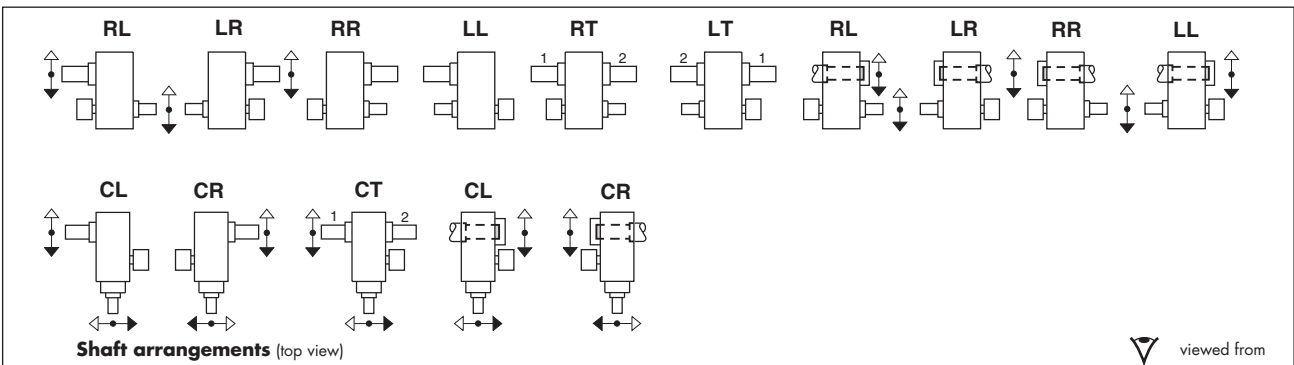
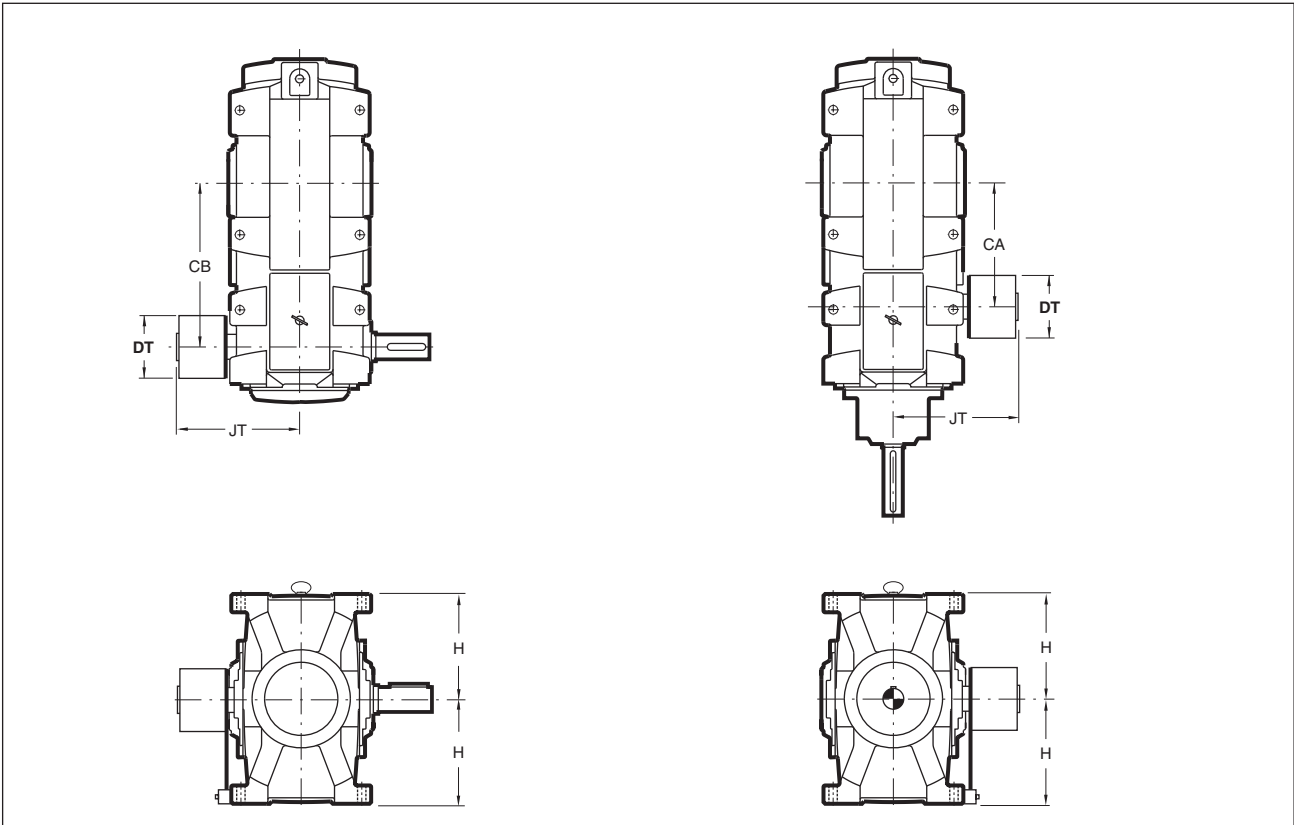

Unit size	Parallel (MHP.2)						Right-angle (MHR.2)					
	Nominal ratio range	Backstop Designation	JT (1)	DT	CB	H	Nominal ratio range	Backstop Designation	JT (1)	DT	CA	H
<b>C</b>	11.2 - 14	600	11.82	5.375	15.079	9.84	11.2 - 31.5	600	11.82	5.375	10.118	9.84
	16 - 40	500	11.57	4.250	15.079							
<b>D</b>	10 - 20	600	12.61	5.375	17.047	11.02	10 - 28	700	13.86	7.125	11.220	11.02
	22.4 - 35.5	500	12.36	4.250	17.047							
<b>E</b>	10 - 12.5	700	14.77	7.125	19.331	12.40	10 - 28	700	14.77	7.125	12.598	12.40
	14 - 35.5	600	13.52	5.375	19.331							
<b>F</b>	11.2 - 18	700	15.88	7.125	22.362	13.98	11.2 - 31.5	750	16.88	8.750	14.606	13.98
	20 - 40	600	14.63	5.375	22.362							
<b>G</b>	11.2	750	18.45	8.750	25.394	15.75	11.2 - 31.5	800	18.45	10.000	16.496	15.75
	12.5 - 28	700	17.45	7.125	25.394							
	31.5 - 40	600	16.20	5.375	25.394							

(1) Without oil reservoir