



Hydraulic Filtration Product Guide

Spin-ons • Cartridges • In-tank • Low Pressure • Medium Pressure • High Pressure • Duplex • Accessories



Donaldson Delivers Performance Under Any Pressure!

Clean, dry oil is essential for your equipment.

Donaldson Company, a leader in filtration for over 100 years, has proven performance in thousands of applications – offering the industry's largest selection of replacement hydraulic, lube and gear oil filtration products for contamination control.

Distributed by:

How Donaldson Displays Filter Flow versus Pressure Loss Data

Pressure Drop (ΔP) Correction Formulae

To properly calculate pressure loss for viscosity and/or specific gravity, use the filter and housing formulae below to determine the clean filter assembly pressure drop.

Filter Correction Calculation

$$\Delta P \text{ Filter} = \Delta P \text{ from graph} \times \frac{\text{New Saybolt Seconds Universal Viscosity (SSU)}}{150} \times \frac{\text{New Specific Gravity (S.G.)}^*}{.90}$$

- or -

$$\Delta P \text{ Filter} = \Delta P \text{ from graph} \times \frac{\text{New Centistokes Viscosity (cSt)}}{32} \times \frac{\text{New Specific Gravity (S.G.)}^*}{.90}$$

Clean Filter Assembly Pressure Drop (ΔP) Calculation

$$\Delta P \text{ Clean Filter Assembly} = \Delta P \text{ head} + \Delta P \text{ filter}$$

*Specific gravity is 0.90 for most hydrocarbon based fluids

Filter, Head or Housing/Assembly Reference

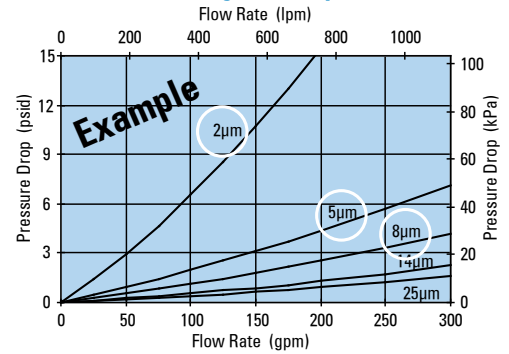

Performance Curve Notes

- All flow measurements were made with 32cSt [150 SSU] hydraulic oil at 100°F (37.7°C), fluid specific gravity of 0.9.
- The performance curves displayed are for the filter, head or housing assembly.
- Filter performance curves will either list media numbers or beta ratings (see circled areas on chart above). These labels correspond with the filter choice tables.

The Importance of Temperature in Determining Pressure Drop

Fluid viscosity plays an important role in restricting the flow through filters. It's crucial to select the proper filter to maintain adequate flow and avoid excessive pressure drops. Measured in centiStokes (cSt) or Saybolt Seconds Universal (SSU or SUS), fluid viscosity is the resistance of a fluid to flow (thickness of fluid). Low viscosity fluids pass through filters with less resistance than high viscosity fluids. Higher fluid viscosities have higher pressure drops due to higher resistance passing through the media. The colder the fluid, the higher the viscosity, so the lowest potential temperature of the fluid is the best measure for calculating pressure drop.

Use the chart below to determine the viscosity of the fluid to be filtered at its lowest potential temperature.

Oil Kinematic Viscosity Combined With Temperature in Centistokes cSt

SAE Gear Oil			75W			80W		85W		90		140		
SAE Engine Oil			5W	10W	20		30	40	50					
ISO Grade			15	22	32	46	68	100	150	220	320	460	680	
°F	°C	Diesel												
248	120				4	4	6	7	9	12	13	18	23	
230	110				4	6	7	9	12	15	19	24	30	
212	100		1	5	5	7	9	11	15	19	25	32	41	
194	90		3	5	7	9	11	15	20	26	34	44	58	
176	80		5	7	9	11	15	20	27	36	48	63	85	
158	70		6	9	11	15	20	28	39	52	71	95	130	
140	60		8	12	15	21	29	40	57	80	110	151	211	
122	50		11	15	22	30	43	62	99	128	181	254	365	
104	40	1	15	22	32	46	68	100	150	220	320	460	680	
86	30	2	21	32	51	76	116	175	271	409	613	907	1,380	
68	20	3	33	51	87	135	214	334	536	838	1,290	1,980	3,130	
50	10	4	52	87	162	264	438	711	1,190	1,920	3,070	4,870	8,020	
32	0	5	85	180	340	585	1,020	1,720	2,990	5,060	8,400	13,900	23,900	
14	-10	9	185	375	820	1,500	2,770	4,880	8,890	15,700	27,200	47,000	85,000	
-4	-20	15	400	800	2,350	4,650	91,20	16,800	32,300	60,000				

Hydraulic Filter Housing Selection Guide

Locate the Donaldson model closest to the intersection of the maximum operating pressure and maximum flow rate. If there is not a model at the exact intersection, select the nearest series to the right or above the intersection to ensure a filter that is adequate to handle the maximum operating pressure and flow rate has been selected.

Pressure families are color coded in the selection chart for low, medium and high model series. Filter housing styles are identified by their shape.

Filter Housing Style Code

● Spin-on
 ■ In-tank Housing / Cartridge
 ▲ In-line Housing / Cartridge

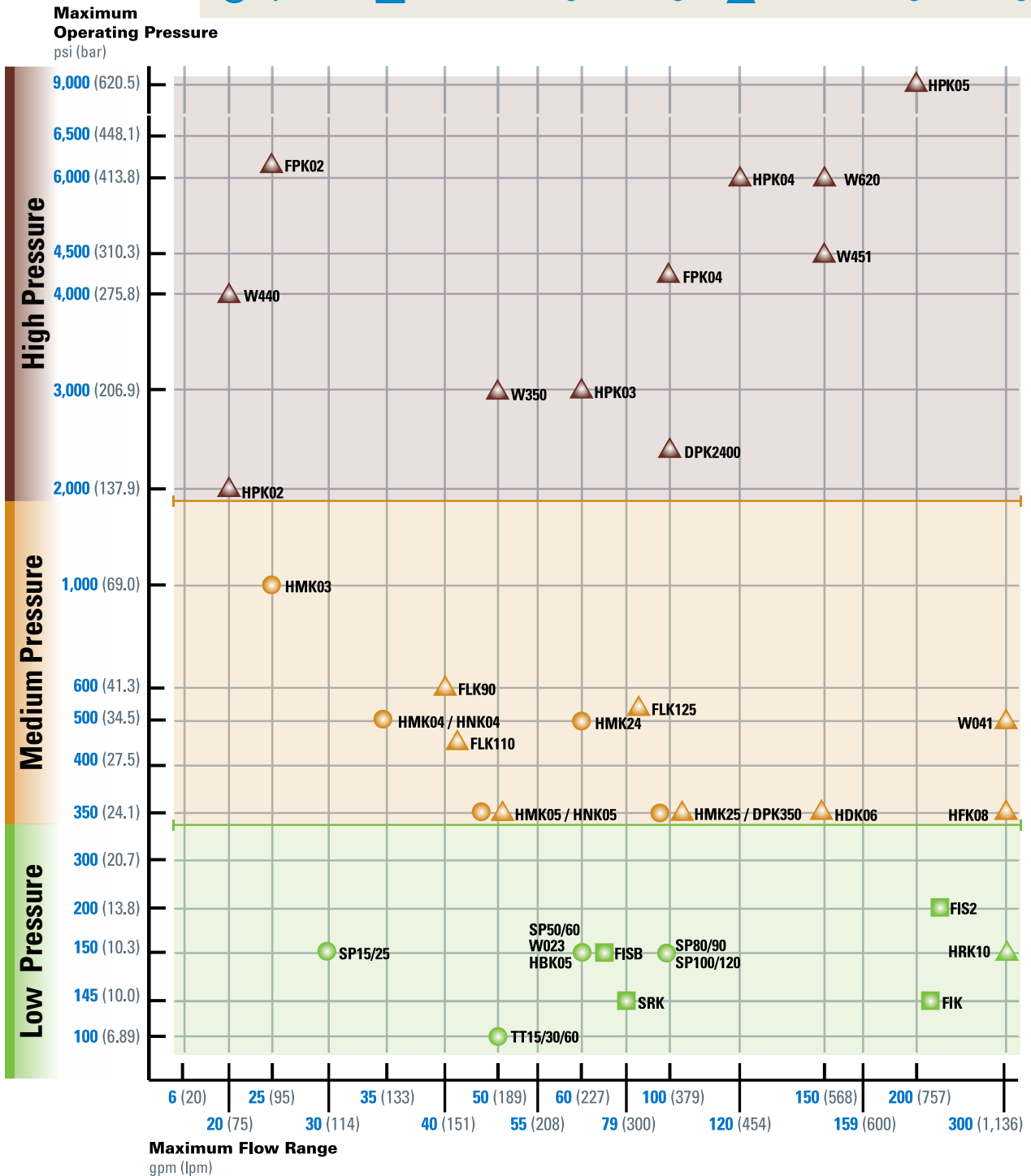

Selecting the Proper Hydraulic Filter

Sensitive hydraulic circuits are vulnerable to a variety of contaminants that result in inefficiency, downtime and excessive repair costs. It is important to remember that protecting and maintaining the most sensitive components within a circuit will result in effective contamination control.

With the broad range of housing styles and filters available from Donaldson, how do you choose the right filter to reliably protect your systems and equipment? Follow these recommended steps to identify the correct Donaldson filter and parts required for efficient contamination control.

1 Determine the system operating pressure and flow rate

Start by identifying two key factors in the hydraulic system operating environment for the most critical component being protected, such as pumps and motors.

- nominal and maximum operating pressure
- nominal and maximum flow rate

2 Select the filter housing model

Refer to the Hydraulic Filter Model Series Selection Guide to select the filter housing that meets your requirements.

- Pressure families are color coded for low, medium and high models.
- Housing styles are identified by their shape code: spin-on, in-tank and in-line
- Porting type options – see page 3 for model series details.

3 Consider application factors when selecting the filter

After the appropriate housing is identified, other application factors must be considered when selecting the appropriate filter. Use the filter choice tables to determine a specific part number.

- components being protected
- ISO Code desired
- fluid type and material compatibility
- oil viscosity (SUS/cSt) and temperature
- vibration/cyclic flow surges
- media type
- flow rate (GPM/LPM)
- maximum allowable pressure drop
- efficiency / beta rating
- seal options
- standard vs. high-performance filters
- servicing and installation convenience

4 Choose the appropriate line and reservoir accessories

Items such as breathers, suction strainers, and gauges are important parts of an overall hydraulic system.

Refer to the Accessories Section for more information.

5 On-going contamination control practices

To optimize system performance and lengthen component life, new oil should be filtered before being transferred into a reservoir or gearbox. Monitor the condition of fluids and identify wear and contamination with regular fluid analysis.

Refer to the Off-Line Filtration and Fluid Analysis Sections for more information.

This publication contains a wide selection of standard and custom hydraulic filtration assemblies for equipment manufacturers – and replacement filters for both Donaldson housings and those produced by other manufacturers. Donaldson assemblies and filters can be used in both mobile and stationary equipment applications. For custom hydraulic filtration systems, please contact your Donaldson supplier.

Overview	2
Hydraulic Filtration Solutions	2-3
Product Line Overview	4-7
Industry Shaping Technology	8
Global Capabilities - Design and Logistic	9
Low Pressure Filters	11
Max Operating Pressure < 350 psi (24 bar)	
Spin-on Filters	12
In-tank Filters	36
In-line Cartridge Filters	56
Medium Pressure Filters	61
Max Operating Pressure < 2000 psi (138 bar)	
Spin-on Filters	62
In-line Cartridge Filters	78
High Pressure Filters	105
Max Operating Pressure < 8,267 psi (570 bar)	
In-line Cartridge Filters	106
Replacement Cartridge Filters	155
Accessories	161
Fluid Analysis	213
Off-Line Filtration	223
Clean Fuel & Lubricant Solutions	235
Technical Reference Guide	239



The best solutions for clean, dry oil.

Count on Donaldson to have the right filters, contamination control products and services to protect critical components in hundreds of applications – in the factory and on heavy-duty mobile equipment.

When you need hydraulic filtration, Donaldson delivers.

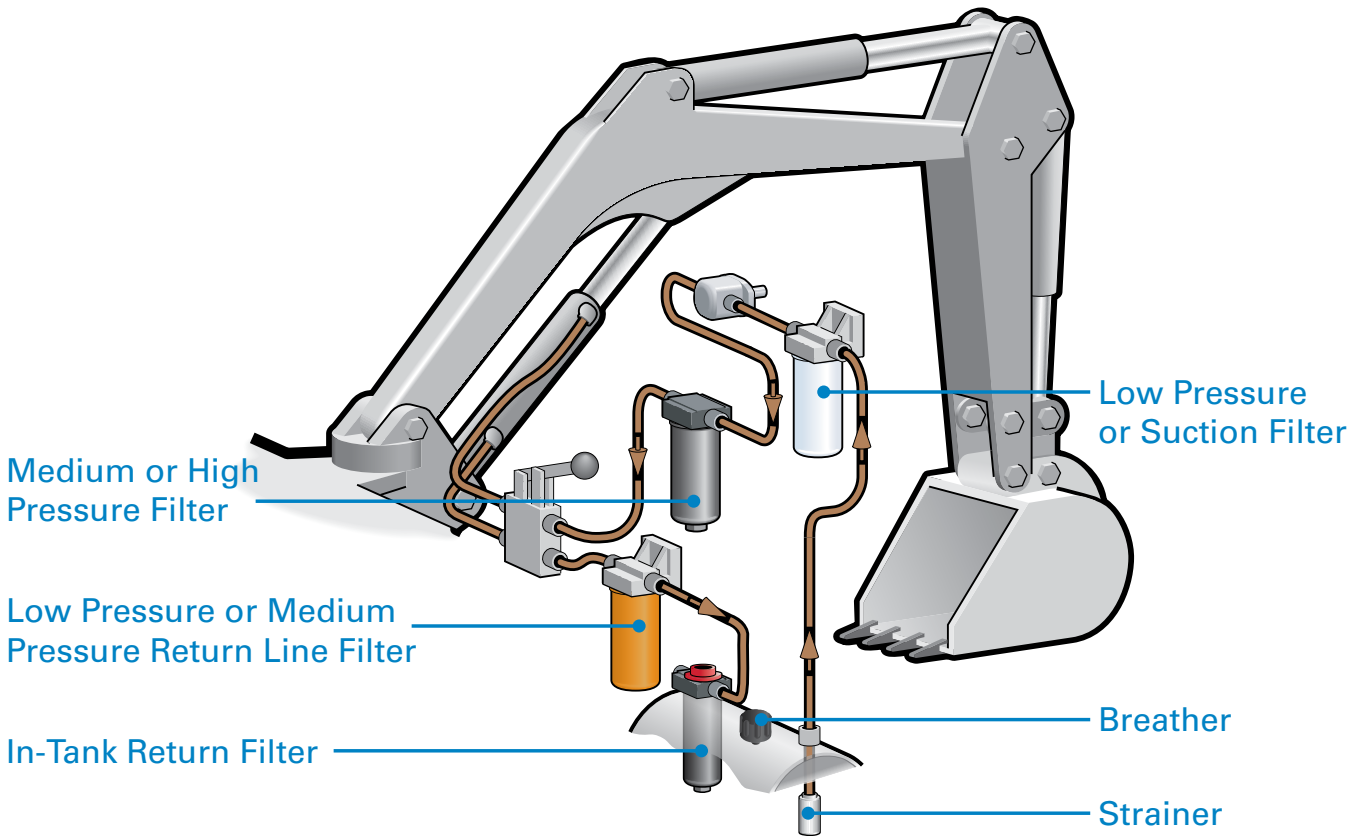



Performance under any pressure

- Low, medium and high pressure filtration
- Spin-on, cartridge and in-tank style filters
- Hydraulic line and reservoir accessories
- T.R.A.P.™ reservoir breather technology

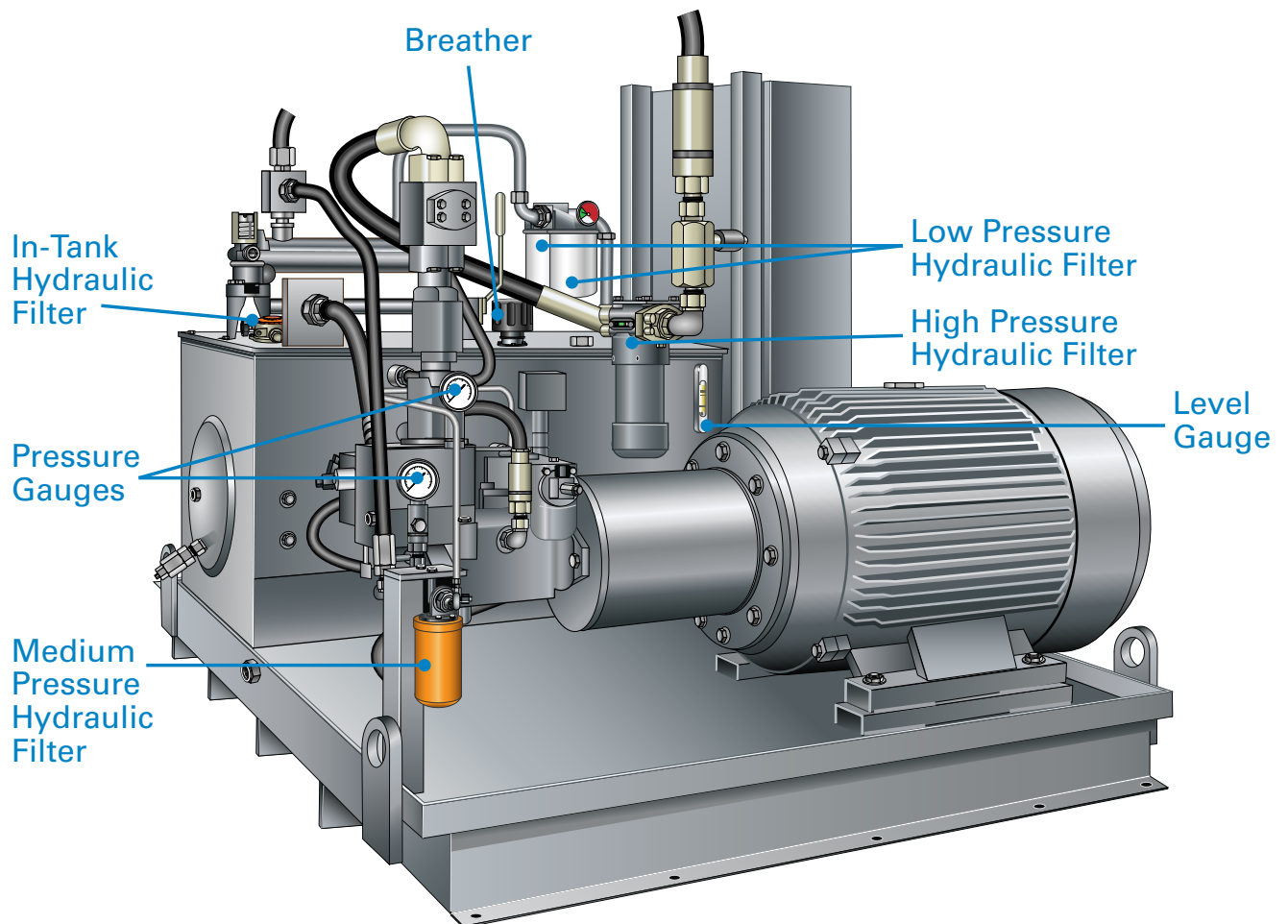



Today's hydraulic systems are intolerant of corrosion, require higher cleanliness standards, and demand higher filtration performance. Hydraulic-powered vehicles and equipment owners desire solutions providing lower cost of operation and ownership. Donaldson works to develop new technologies that meet your engineering specifications and add customer value.

Low Pressure Filtration

Max operating pressure < 350 psi (24 bar)



Low pressure filters are the most commonly used type of filter in hydraulic circuits, used most often in return line applications.

Donaldson low pressure filters are rated for working pressures up to 350 psi (2400 kPa). In-tank and in-line configurations are available to accommodate virtually any application.

- Sensors, valves, and switches in various styles and port sizes
- Unique filtration performance options
- Integrated mounting brackets
- Broad range of package sizes
- Custom design options

Medium Pressure Filtration

Max operating pressure < 2,000 psi (138 bar)



Medium pressure filters can be used in applications up to 2000 psi (13790 kPa). Donaldson offers both spin-on and in-line cartridge-style filters.

Donaldson Duramax® filters are the highest rated medium pressure spin-on filters available. Duramax filters are proven, reliable, long-lived and easy to install.

- Die-cast and sand-cast custom head assemblies integrated into systems
- Enhanced system component protection
- Customized to existing filter interface – no system modification required

High Pressure Filtration

Max operating pressure < 6,500 psi (450 bar)



High pressure filters are positioned between pumps and critical components such as cylinders, motors and valves. They help protect these critical components from catastrophic failure.

Donaldson heavy-duty high pressure filters are rated for working pressures up to 6500 psi (44818 kPa). Various porting sizes and types, including manifold style, are available for a wide range of applications.

- High-performance filtration media options such as Synteq™
- Metal or plastic material options
- Multiple head interfaces



	Model Series	Max Flow gpm (lpm)		Max Pressure psi (kPa) / bar		Porting Size Options	Page No.	
Low Pressure Filtration Pages 11-60	Spin-on Filters							
	SP15/25	30	(114)	150	(1035)	/ 10.3	½", ¾" NPT, SAE-8, -12 O-ring	12
	W023	60	(227)	150	(1035)	/ 10.3	1¼" NPT, SAE-20 O-ring	16
	HBK05	60	(227)	150	(1035)	/ 10.3	1¼" NPT, SAE-20 O-ring	18
	SP50/60	60	(227)	150	(1035)	/ 10.3	1¼" NPT, SAE-20 O-ring	22
	SP80/90	100	(379)	150	(1035)	/ 10.3	1½" NPT, SAE-24 O-ring, 2" SAE 4-Bolt Flange Code 61	26
	SP100/120	100	(379)	150	(1035)	/ 10.3	1½" NPT	30
	TT15/30/60	50	(189)	100	(689)	/ 6.89	¾", 1½" NPT	34
	In-tank Filters							
	FIS2	150	(568)	200	(1379)	/ 13.8	1½" SAE 4 Bolt Flange Code 61, 2" SAE 4 Bolt Flange Code 61 & SAE-24 O-ring, 2" SAE 4 Bolt Flange Code 61 & 1½" G Thread (BSPP)	36
	FISB	70	(265)	150	1035	10.3	SAE-16, SAE-20	40
	FIK	170	(644)	145	(1000)	/ 10.0	½" NPT, ¾" NPT, 1" NPT, SAE-8,-12,-16,-20,-24 O-ring, 2" SAE 4-Bolt Flange Code 61	44
	SRK Combo	79	(300)	145	(1000)	/ 10.0	Inlet: SAE-16, -20 O-ring, Outlet: SAE-16 O-ring	54
	In-line Cartridge Filters							
HRK10	300	(1136)	150	(1035)	/ 10.3	4" ANSI Flange, 8-bolt 150#	56	
Medium Pressure Filtration Pages 61-104	Spin-on Filters							
	HMK03	25	(95)	1000	(6895)	/ 69.0	SAE-12 O-ring	62
	HMK04	35	(133)	500	(3450)	/ 34.5	¾", 1" NPT, SAE-12, -16 O-ring	66
	HNK04	35	(133)	500	(3450)	/ 34.5	SAE-12, -16 O-ring	74
	HMK05	50	(189)	350	(2415)	/ 24.2	1¼" NPT, SAE-20 O-ring	70
	HNK05	50	(189)	350	(2415)	/ 24.2	SAE-20 O-ring	74
	HMK24	60	(227)	500	(3450)	/ 34.5	SAE-20 O-ring, 1¼" SAE 4-Bolt Flange Code 61	66
	HMK25	100	(379)	350	(2415)	/ 24.2	1½" NPT, SAE-24 O-ring, 1½" SAE 4-Bolt Flange Code 61	70
	In-line Cartridge Filters							
	FLK90	40	(151)	580	(4002)	/ 40.0	SAE-12, -16 O-ring	79
	FLK110	42	(159)	435	(3001)	/ 30.0	SAE-20 O-ring	82
	FLK125	85	(322)	508	(3505)	/ 35.1	2" SAE 4-Bolt Flange Code 61	85
	DPK350	100	(379)	350	(2415)	/ 24.2	1½" SAE 4-Bolt Flange Code 61	88
	HDK06	150	(568)	350	(2415)	/ 24.1	2½" NPT	92
W041	300	(1136)	500	(3450)	/ 34.5	2" or 2½" SAE 4-Bolt Flange Code 61	96	
HFK08	300	(1136)	350	(2415)	/ 24.1	3" NPT, SAE-20 O-ring	100	
High Pressure Filtration Pages 105-154	In-line Cartridge Filters							
	HPK02	20	(76)	2000	(13790)	/ 137.9	SAE-12 O-ring	106
	DPK2400	100	(379)	2400	(16547)	/ 165.4	1½" SAE 4-Bolt Flange Code 61	111
	W440	20	(76)	4000	(27580)	/ 275.8	SAE-12 O-ring or Manifold Mounting	114
	FPK02	25	(95)	6090	(42021)	/ 420.0	SAE-12 O-ring	118
	W350	50	(189)	3000	(20685)	/ 206.9	SAE-16 O-ring	123
	HPK03	60	(227)	3000	(20685)	/ 206.9	SAE-12, -16 O-ring	127
	FPK04	100	(379)	4350	(30015)	/ 300.1	SAE-20 O-ring	132
	HPK04	120	(454)	6000	(41380)	/ 413.8	SAE-20 O-ring, 1¼" or 1½" SAE 4-Bolt Flange Code 61 or 62	137
	W451	150	(568)	4500	(31027)	/ 310.3	SAE-24 O-ring, 1½" SAE 4-Bolt Flange Code 61 or 62, Manifold Mounting	143
	W620	150	(568)	6000	(41380)	/ 413.8	SAE-16, -20, -24 O-ring, 1¼" SAE 4-Bolt Flange Code 62, 1½" SAE 4-Bolt Flange Code 61	147
HPK05	200	(757)	8267	(57000)	/ 570	2" SAE 4-Bolt Flange Code 62	152	



Off-Line Filtration

The Donaldson Filter Cart, Filter Panel and Filter Buddy™ offer convenient off-line filtration, flushing and fluid transfer. Use them with your stationary and mobile equipment to achieve and maintain proper ISO cleanliness levels.

Filter Cart

Designed with performance, convenience and safety in mind. Includes value-added features to protect your machinery and equipment from breakdowns caused by contamination.

Filter Panel

Provides fixed/mounted offline filtration and a turn-key approach to supplemental filtration.

Filter Buddy™

This handheld portable system provides the capability to kidney loop reservoirs that you normally cannot reach with larger filter carts. Its small size and light weight allow for carrying up and down stairs and access into tight spaces.



Replacement Filters

The Industry's Largest Selection of In-Stock Replacement Filters!

Donaldson offers a complete line of hydraulic filter heads and housings for low, medium, and high pressure applications. Spin-ons and cartridges are available in a wide range of filter medias.

When replacing another filter brand, our comprehensive and up-to-date cross-reference guide, available at shop.donaldson.com, can guide you through performance improvement possibilities.

Our worldwide network of authorized distributors is ready to serve you with their extensive experience with hydraulic circuits and with Donaldson filters. Most distributors stock our filters and we have quick-ship programs so you can get the filter you need, when you need it.



Accessories

Accessories for hydraulic circuits, lines and reservoirs that will help you maintain proper ISO cleanliness levels.

Filter Service Indicators

- Service indicators to maximize filter life

Hydraulic Line Accessories

- Pressure gauges for monitoring system pressure
- Hoses and test points for sampling oil and determining ISO cleanliness levels
- Flanges to connect components
- Valves for system control



Reservoir Accessories

- Suction strainers help protect pumps from damage
- Diffusers for reducing aeration, foaming, turbulence and noise caused by return lines
- Sight and level gauges available, including plastic or steel screw-in styles for use in a variety of applications
- Plugs, caps and vents for small power units and gearboxes
- Filler breathers and caps come in chrome, zinc, epoxy-coated weatherproof finishes, and corrosion-resistance techno polymer – lockable, dipsticks and side-mount versions available



T.R.A.P.™ Breather Technology (*Thermally Reactive Advanced Protection*)

T.R.A.P. breathers provide fast-acting protection against airborne moisture and particulate contamination. They stop solid particulate down to 3 μm at 97% efficiency and prevent moisture from entering the reservoir. Water-holding capacity is regenerated with every oil return phase. This self-regenerating capability enables extended breather life.



Warranty

Donaldson warrants its aftermarket products against failure due to defects in materials and workmanship for the period specified under the Terms and Conditions for the particular product. You have a choice. You can always choose top-quality Donaldson filters designed specifically for your engines and equipment and – as long as you change them according to the engine manufacturer’s maintenance schedule – using Donaldson filters will not void your engine manufacturer’s warranty.

Go to donaldson.com to learn out more on our aftermarket warranty.

Filter Media Design and Development

From traditional cellulose to synthetic, the development of proprietary filtration substrates is at the heart of every Donaldson filtration system. If our existing media formulation doesn't meet our customer's specifications, our scientists use our in-house media development laboratory to design new formulations to meet your needs.

Media Characterization Testing

- Permeability
- Tensile strength
- Mullen burst
- Basis weight
- Pore size
- Thickness
- Gurley stiffness
- LEFS bench
- 3-Point bend

In-House Media Mill

- For application development
- Trial media production runs
- Development of proprietary formulations

Filtration Performance Testing

- Particle counting
- Multi-pass testing
- Water removal efficiency

Donaldson Media Formulations Set the Standard for Filtration Performance!

Donaldson offers over 35 different media formulations for hydraulic filters, allowing our engineers to deliver filtration solutions that meet our customer's unique requirements.

We use a variety of techniques to enhance filter media so it can withstand the high differential pressures found in hydraulic systems. Oven-curing, wire backing and multiple layers all contribute to our media integrity. Our medias include:

DT Synthetic High-Performance Media

DT High-Performance media utilizes a blend of synthetic fibers optimizing efficiency and initial pressure drop. Donaldson filter media scientists found this to provide the best available chemical resistance for the broadest array of hydraulic applications. This media is also ideal for use with phosphate ester and water glycol fluids.

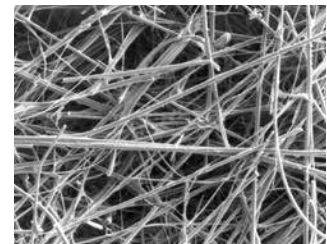

Alpha-Web™ Synthetic Media

Alpha-web is a multi-layered synthetic media that utilizes a fine fiber layer that traps and locks particles. This media outperforms conventional medias in cyclic flow efficiency testing and real world hydraulic conditions.

ALPHA-WEB™

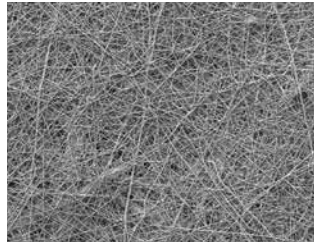

Synteq™ Synthetic Media

This media's uniform synthetic fiber structure delivers higher filtration efficiency and longer filter life. Synteq filter media technology is ideal for synthetic fluids, water glycols, water/oil emulsions, HWCF (high water content fluids) and petroleum-based fluids. The smooth rounded fibers provide low resistance to fluid flow.

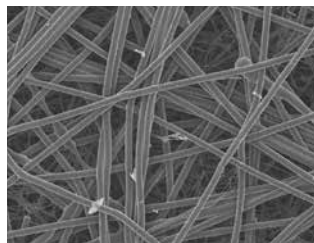

Cellulose Media

This media often has lower beta ratings, providing effective filtration for a wide variety of petroleum-based fluids. The smaller pores result in greater flow resistance, in turn causing higher pressure drop.

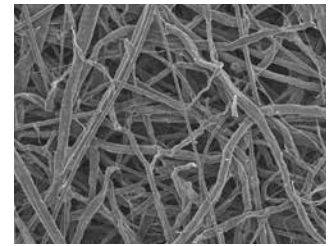

Water Absorbing Media

This media is formulated with absorbents and resins to remove moisture and condensation from petroleum-based fluids.

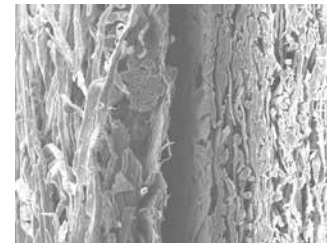

Wire Mesh Media

Wire mesh media consists of stainless steel, epoxy-coated wire mesh. This media is used to catch very large, harsh particulate that would rip up a normal filter. It is also useful as a coarse filter in viscous fluid applications.

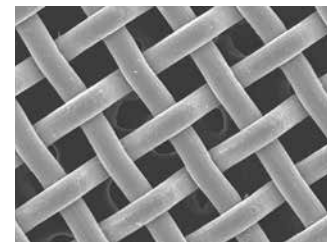



Donaldson has pioneered the use of a wide range of engineering, design and testing tools used during the product development and validation process.

Engineering Capabilities

- Global design centers
- Prediction and simulation

Development and Validation

- Filtration performance testing per SAE and ISO standards

Test & Evaluation Tools

- Structural analysis per SAE, ISO, and NFPA standards
- Filtration performance testing
- Analytical chemistry laboratory

Design Validation

- Global test cell locations
- Tests for: pressure drop, high temp, flow fatigue, used oil analysis, component durability, and fluid compatibility
- Vibration/Shaker
- Field testing
- Field data acquisition

Quality Certified

- All facilities are ISO/AS certified
- Quality controls

Manufacturing

- Global manufacturing locations
- Engineered and manufactured to ensure long-life, durability, corrosion resistance and liquid compatibility
- Packaging options to meet international shipping and compliance specifications

Logistics / Distribution

- Global distribution network
- Regional distribution centers
- Transportation, third party logistics, consolidators and cross-docking networks





Low Pressure Filters

Low pressure filters are the most common type of filter found in hydraulic circuits – used most often in return line applications.

Donaldson low pressure filters are rated for working pressures up to 350 psi (2400 kPa). In-tank and in-line configurations are available to accommodate virtually any application.



Section Index

Max Operating Pressure < 350 psi (24 bar)

Models arranged from low to maximum flow rates

Spin-on Filters

SP15/25	12
W023	16
HBK05	18
SP50/60	22
SP80/90	26
SP100/120	30
TT15/30/60	34

In-tank Filters

FIS2	36
FISB	40
FIK	44
SRK Combo	54

In-line Cartridge Filters

HRK10	56
-------------	----



SP15/25 Spin-On Filters

Maximum Working Pressures to:

150 psi / 1035 kPa / 10.3 bar

Rated Static Burst to:

375 psi / 2590 kPa / 25.9 bar

Flow Range To:

30 gpm / 114 lpm

Features

The SP15/25 series are economical, low pressure filters with spin-on convenience and a wide range of cleanliness ratings. Filters are available with the bypass ratings of your choice – 25 psi, 15 psi, 5 psi or no bypass. Take advantage of our mix and match system of in-stock heads and filters, so you can get exactly what you need. Choose the media type and configuration that's best for your application. Options include Donaldson's exclusive Synteq™, natural fiber cellulose, stainless steel wire-mesh or water absorbing media.

Beta Rating

- Performance to $\beta_{6(c)}=1000$

Porting Size Options

- 1/2", 3/4" NPT
- SAE-8, SAE-12 O-Ring

Replacement Filter Lengths

- 5.35" / 136mm
- 7.87" / 200mm

Standard Bypass Ratings

- 25 psi / 172.5 kPa / 1.7 bar
- 15 psi / 97 kPa / .97 bar
- 5 psi / 34.5 kPa / .34 bar
- No Bypass

Applications

- Fluid Conditioning Systems
- In-Plant Systems
- Mobile Equipment
- Power Transmissions
- Process Systems



Assembly Weight

- 5.35": 1.6 lbs / .7 kg (approximately)
- 7.87": 2.2 lbs / 1 kg (approximately)

Operating Temperatures

- -22°F to 225°F / -30°C to 107°C

Filter Collapse Ratings

- 100 psid / 690 kPa / 6.9 bar (standard)

SP15/25 Specification Illustrations

ASSEMBLY - SIDE VIEW

All dimensions are shown in inches [millimeters].

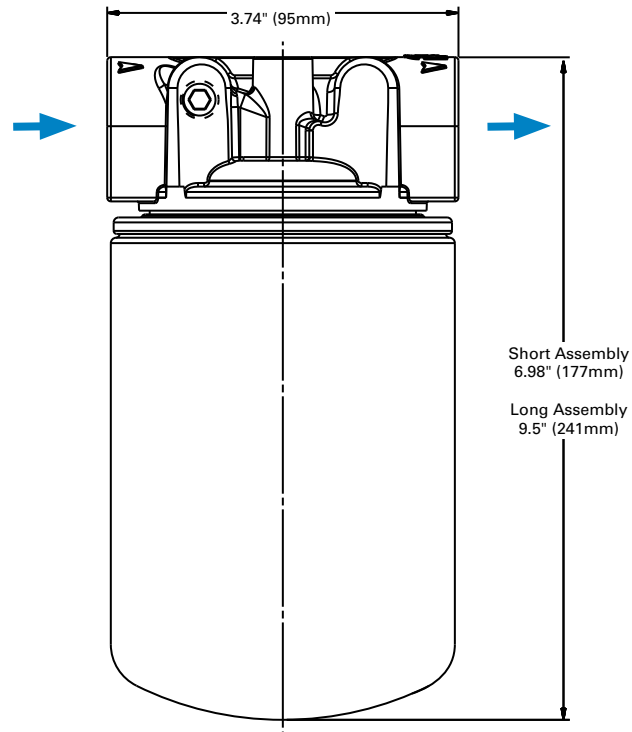

HEAD - TOP VIEW

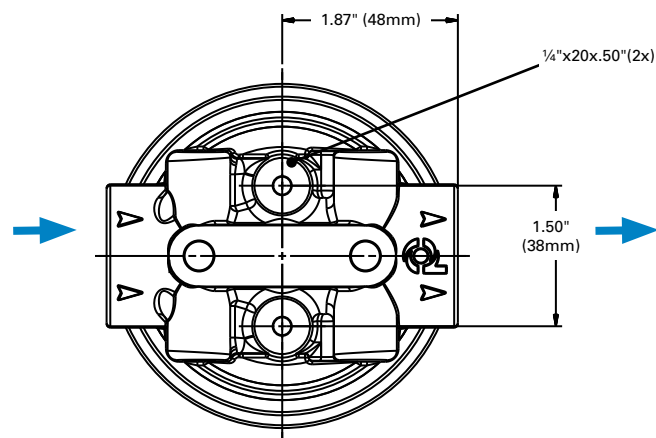



SP15/25 Components

Filter Choices

Media Type	$\beta_{x(c)} = 2$	$\beta_{x(c)} = 1000$	Length		Part No.	Comments
	Rating based on ISO 16889		in	mm		
Synteq Synthetic		6 μm	5.35	136	P564967	
		6 μm	7.87	200	P564357	
		11 μm	7.87	200	P179089	
		11 μm	5.35	136	P560693	
		23 μm	5.35	136	P560694	
Cellulose	5 μm		5.35	136	P565061	
	7 μm		5.35	136	P551551	
	7 μm		7.87	200	P565059	
	17 μm		5.35	136	P551553	
	17 μm		7.87	200	P565060	
Water Absorbing	10 μm		5.35	136	P565062	Absorbs approximately 6 oz/170 ml of water @ 20 psid/1.4 bar
Wire Mesh	150 μm		5.35	136	P550274	100 mesh

Filter Notes: * Thread size 1"-12 UNF

Head Choices

Port Size	Bypass Range	Gauge ports (drill, tap, plug)	Gauge Port Location	Part No.
1/2" NPT	15 psi / 103.4 kPa / 1.34 bar	(2) 1/8" NPT	upstream side	P563288
3/4" NPT	25 psi / 172.5 kPa / 1.72 bar	(2) 1/8" NPT	upstream side	P561131
3/4" NPT	5 psi / 34.5 kPa / .34 bar	(2) 1/8" NPT	downstream side	P561132
3/4" NPT	25 psi / 172.5 kPa / 1.72 bar	none	na	P561134
3/4" NPT	5 psi / 34.5 kPa / .34 bar	none	na	P561135
3/4" NPT	none	none	na	P561136
3/4" NPT	15 psi / 103.4 kPa / 1.34 bar	none	na	P563278
SAE-12	none	none	na	P561133
SAE-12	none	(1) SAE-4	upstream side, LH	P561137
SAE-12	5 psi / 34.5 kPa / .34 bar	none	na	P561140
SAE-12	25 psi / 172.5 kPa / 1.72 bar	none	na	P561141
SAE-12	15 psi / 103.4 kPa / 1.34 bar	none	na	P563279
SAE-12	25 psi / 172.5 kPa / 1.72 bar	(2) 1/8" NPT	upstream side	P563280
SAE-8	25 psi / 172.5 kPa / 1.72 bar	none	na	P561138

Note: On a return line system the gauge port should be on the upstream side. We suggest a 25 psi bypass. If head is used on a suction line, the gauge port should be on the downstream side very low bypass.



Mix and Match

Donaldson's mix and match system provides the great performance and functional advantages of custom engineered filters with the convenience and speedy delivery of in-stock parts. Choose your options and build a filter model to suit your specifications.

Filter Service Gauges - Visual Indicators

Part No.	Pressure Range	Use With Bypass Valve Rating	Type
P563978	5 to 30 psi field adj.*	15 psi / 103.4 kPa / 1.34 bar or 25 psi / 172.5 kPa / 1.72 bar or No Bypass	Return indicator, electrical
P579714	0 to 100 psi	15 psi / 103.4 kPa / 1.34 bar or 25 psi / 172.5 kPa / 1.72 bar or No Bypass	Return indicator, numeric scale
P579715	0 to 100 psi	15 psi / 103.4 kPa / 1.34 bar Bypass	Return indicator, color coded
P579716	0 to 100 psi	25 psi / 172.5 kPa / 1.72 bar or No Bypass	Return indicator, color-coded
P579717	0 to -30 Hg	5 psi / 34.5 kPa / .34 bar or No Bypass	Suction indicator, numeric scale

P563978

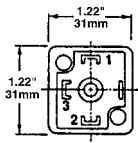

#1 Common; #2 Normally Closed;
#3 Normally Open

Instructions

1. Remove DIN adaptor
2. Remove small brass screw
3. Using 1/8" allen wrench adjust clockwise to increase set point/counter-clockwise to decrease set point
4. NO / NC

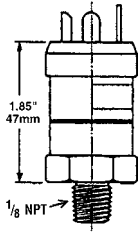

Adjustment screw located in center of electric prongs

P579714 - P579717

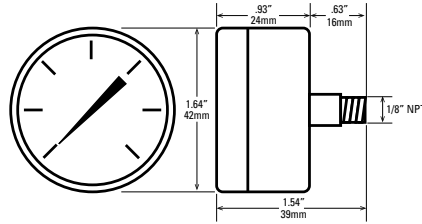

Notes

* NOT PRESET: Setting adjustable for desired application

Performance Data

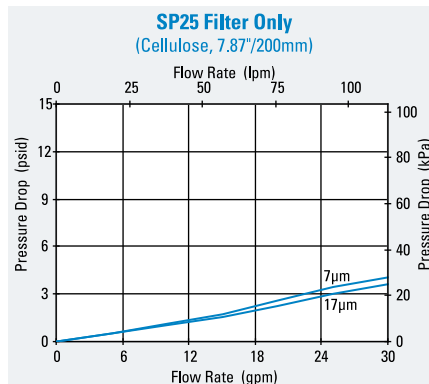
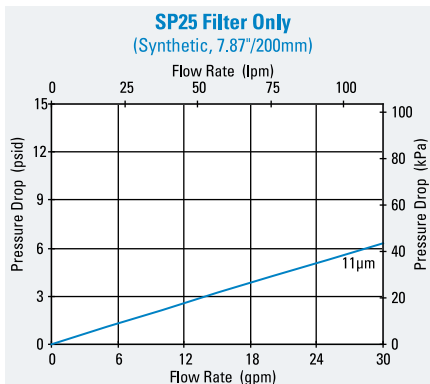
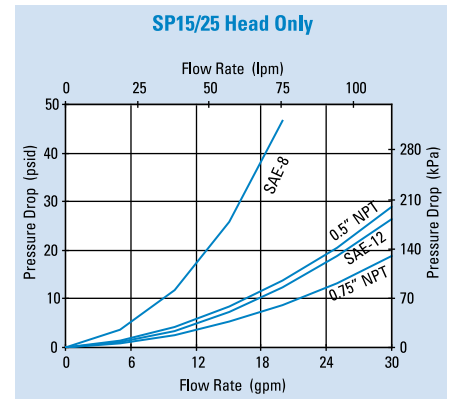
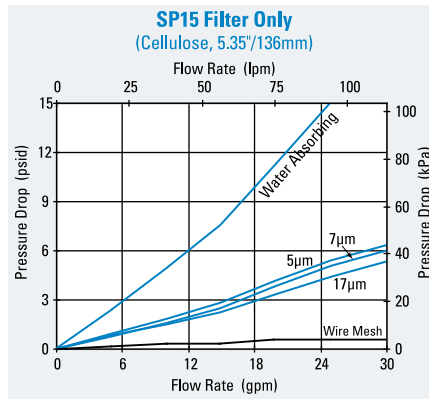
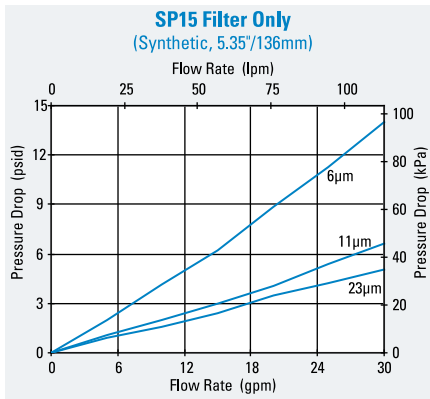



W023

Max Flow: 60 gpm (227 lpm)



W023 Spin-On Filters

Working Pressures to:

150 psi / 1035 kPa / 10.3 bar

Rated Static Burst to:

250 psi / 1725 kPa / 17.2 bar

Flow Range To:

60 gpm / 227 lpm

Applications

- Fluid Conditioning Systems
- In-Plant Systems
- Mobile Equipment
- Power Transmissions
- Process Systems



Features

This versatile spin-on series is an excellent choice for use in high corrosion environments. The gray iron head construction can be ordered with a differential pressure indicator port. Take advantage of our mix and match system of heads and filters, so you get exactly what you need. You can choose the media type and configurations that's best for your application.

Beta Rating

- Performance to $\beta_{<4(c)}=1000$

Porting Size Options

- 1 1/4" NPT
- SAE-20 O-Ring

Performance Data

Replacement Filter Lengths

- 6.7" / 170mm
- 10.7" / 271mm

Standard Bypass Ratings

- 50 psi / 345 kPa / 3.5 bar
- No bypass

Assembly Weight

- 7.0 lbs / 3.2 kg (short)
- 8.0 lbs / 3.6 kg (long)

Operating Temperatures

- -22°F to 225°F / -30°C to 107°C

Filter Collapse Ratings

- 100 psid / 690 kPa / 6.9 bar

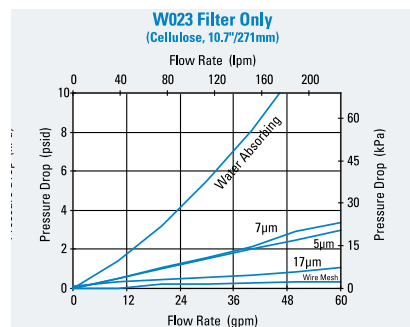
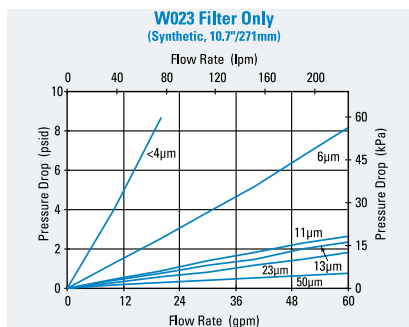
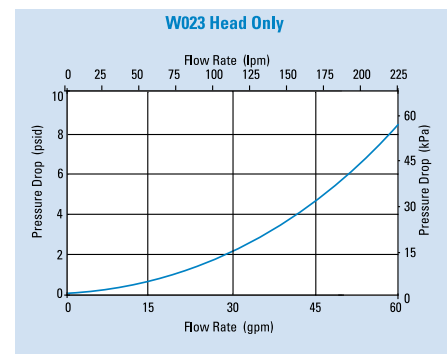
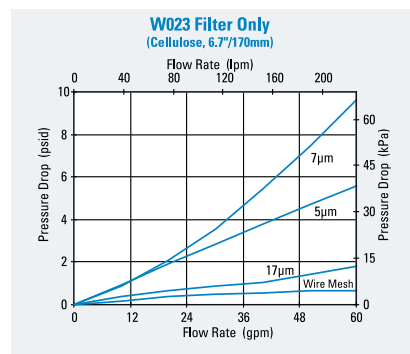
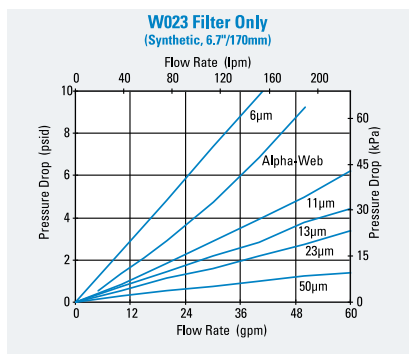

W023 Components

Filter Choices

Media Type	$\alpha_{x(c)} = 1000$	$\beta_{x(c)} = 2$	$\beta_{x(c)} = 1000$	Length		Part No.	Comments
	Rating based on ISO 23369	Rating based on ISO 16889		in	mm		
Synteq Synthetic			<4 μm	10.7	271	P167796	Fluorocarbon O-Ring & square seal kit. Compatible w/ water glycol.
			6 μm	6.7	170	P167162	3-seal kit
			6 μm	10.7	271	P165762	3-seal kit
Alpha-Web	10 μm			6.7	170	DBH5875	3-seal kit
Synteq Synthetic			11 μm	6.7	170	P165875	3-seal kit
			11 μm	10.7	271	P165876	3-seal kit
			13 μm	6.7	170	P167944	Fluorocarbon O-Ring & square seal kit. Compatible w/ water glycol.
			13 μm	10.7	271	P167945	Fluorocarbon O-Ring & square seal kit. Compatible w/ water glycol.
			23 μm	6.7	170	P165877	3-seal kit
			23 μm	10.7	271	P165878	3-seal kit
			50 μm	6.7	170	P165879	3-seal kit
Cellulose		5 μm		6.7	170	P550386	3-seal kit
		5 μm		10.7	271	P550250	3-seal kit
		7 μm		7.2	183	P550388	3-seal kit
		7 μm		10.7	271	P550251	3-seal kit
		17 μm		6.7	170	P550387	3-seal kit
Water Absorbing		10 μm		10.7	271	P561183	Cellulose media, 3-seal kit. Absorbs 350 ml water.
		150 μm		6.7	170	P550275	Stainless steel wire mesh, 3-seal kit
Wire Mesh		150 μm		10.7	271	P550276	Stainless steel wire mesh, 3-seal kit

Filter Notes: * All models have 1 1/2-16 UNF threads except where otherwise noted. All models measure 5.0"/127mm outer diameter.

Head Assembly Choices

Port Size	Bypass Rating	Seal Material	Indicator Style & Location	Part No.
SAE-20 O-Ring	50 psi / 3.45 bar	Nitrile	Port Machined & Plugged	P574241
1-1/4" NPT	None	Nitrile	Port Machined & Plugged	P575930

Indicator Choices

Indicator Pressure Setting	Connector Style	Seal Material	Part No.	Thermal Lockout	Surge Control	Reset
Visual Pop-up Models						
15 psi / 103 kPa	N/A	Nitrile	P572345	No	No	Auto
35 psi / 241 kPa	N/A	Nitrile	P572347	No	No	Auto
35 psi / 241 kPa	N/A	Nitrile	P572348	Yes	Yes	Manual
35 psi / 241 kPa	N/A	Fluorocarbon	P567456	Yes	Yes	Manual
Electrical / Visual Models						
15 psi / 103 kPa	Hirschmann	Nitrile	P572323	No	No	Auto
35 psi / 241 kPa	Hirschmann	Nitrile	P572327	No	No	Auto
35 psi / 241 kPa	Hirschmann	Nitrile	P572384	Yes	Yes	Manual
35 psi / 241 kPa	Hirschmann	Fluorocarbon	P567458	Yes	Yes	Manual
35 psi / 241 kPa	3-wire flying leads	Nitrile	P572349	No	No	Auto
Electrical Models						
15 psi / 103 kPa	Hirschmann	Nitrile	P572355	No	No	Auto
35 psi / 241 kPa	Hirschmann	Nitrile	P572359	No	No	Auto

W023 Specification Illustrations

ASSEMBLY - SIDE VIEW

All dimensions are shown in millimeters [inches].

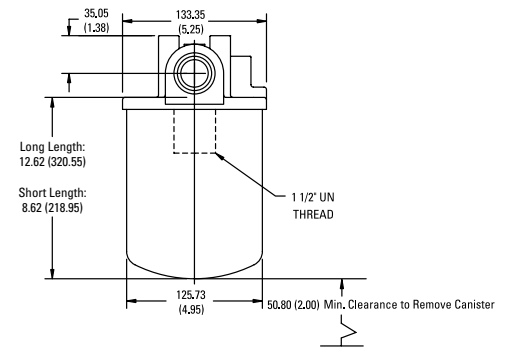

HEAD - TOP VIEW

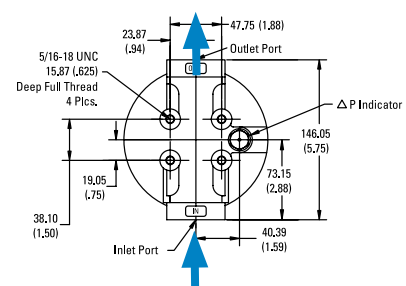



HBK05

Max Flow: 60 gpm (227 lpm)



HBK05 Spin-On Filters

Working Pressures to:

150 psi / 1035 kPa / 10.3 bar

Rated Static Burst to:

250 psi / 1725 kPa / 17.2 bar

Flow Range To:

60 gpm / 227 lpm

Applications

- Cooling Circuits
- Fluid Conditioning Systems
- Hydrostatic Charge Pumps
- Lube Oil Systems
- Power Transmissions
- Return Lines
- Side Loop Systems

Features

HBK05 is a strong and durable low pressure filter with a spin-on design that simplifies servicing and reduces maintenance costs. Its heavy-duty steel canister has a rigid steel attachment plate for added strength. The head-to-canister O-Ring seal is designed to ensure seal integrity beyond 250 psi/17 bar. The head is made of die-cast aluminum.

Take advantage of our mix and match system of in-stock heads and filters — so you can get exactly what you need, HBK05 is available with your choice of visual or electrical service indicators, and bypass ratings of 50 psi, 25 psi, or 5 psi. The filter media is Synteq™, our proprietary synthetic media specifically designed for liquid filtration.

HBK05 filters ship with "L", square, and O-Ring gaskets (unless noted with fluorocarbon seals, then with square and O-Ring gaskets). All HBK05 filters are interchangeable with SP50/60, SP80/90 and SP100/120 spin-ons, and have 1½" - 16 UN threads.



Beta Rating

- Performance to $\beta_{<4(c)}=1000$

Porting Size Options

- 1¼" NPT
- SAE-20 O-Ring

Replacement Filter Lengths

- 6.7" / 170mm (short)
- 10.7" / 271mm (long)

Standard Bypass Ratings

- 50 psi / 345 kPa / 3.4 bar
- 25 psi / 172.5 kPa / 1.7 bar
- 5 psi / 34.5 kPa / .34 bar

Assembly Weight

- 6.9 lbs / 3.1 kg (long)
- 5.7 lbs / 2.6 kg (short)

Operating Temperatures

- -22°F to 225°F / -30°C to 107°C

Filter Collapse Ratings

- 125 psid / 863 kPa / 8.6 bar

HBK05 Specification Illustrations

ASSEMBLY - SIDE VIEW

All dimensions are shown in inches [millimeters].

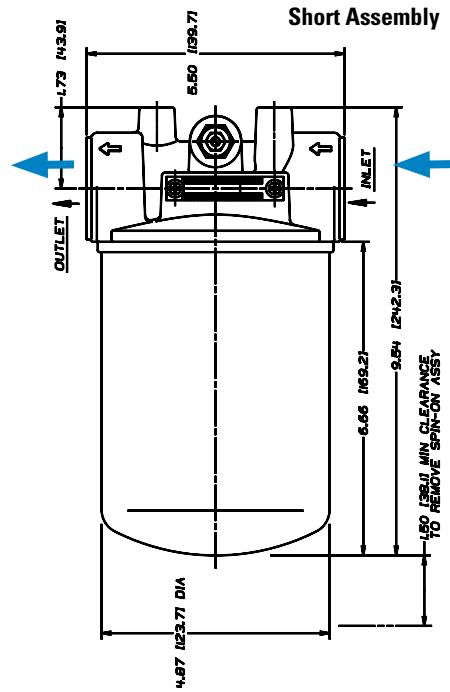
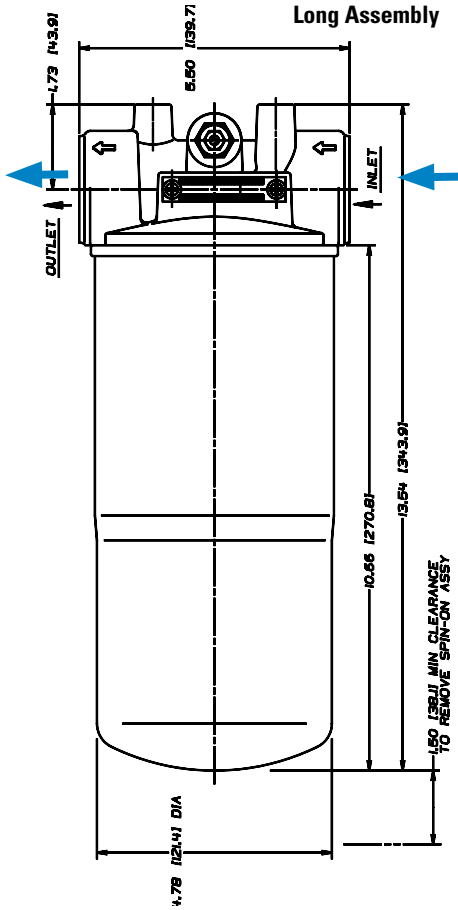

HEAD - TOP VIEW

with DC Electrical Service Indicator

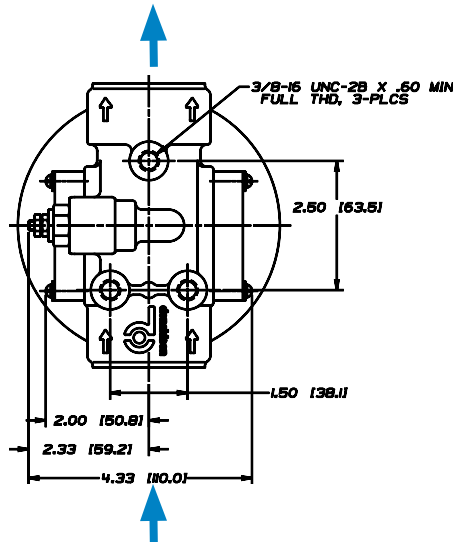

with AC/DC Electrical Service Indicator

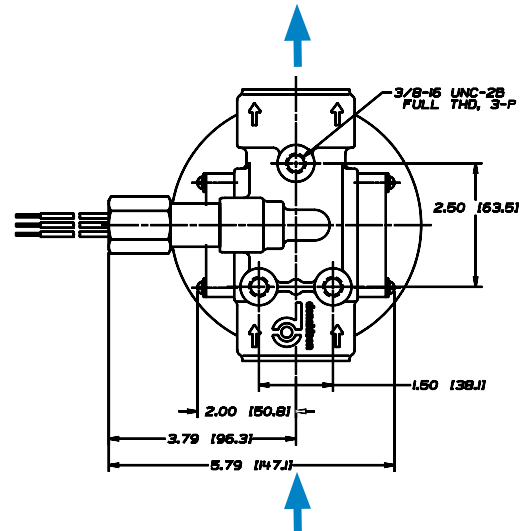



HBK05 Components

Filter Choices

Media Type	$\alpha_{x(c)} = 1000$	$\beta_{x(c)} = 2$	$\beta_{x(c)} = 1000$	Length		Part No.	Comments
	Rating based on ISO 23369	Rating based on ISO 16889		in	mm		
Synteq Synthetic			<4 μm	10.7	271	P167796	Fluorocarbon seal. Compatible with water glycol.
			6 μm	6.7	170	P167162	
			6 μm	10.7	271	P165762	
Alpha-Web	10 μm			6.7	170	DBH5875	3-seal kit
Synteq Synthetic			11 μm	6.7	170	P165875	
			11 μm	10.7	271	P165876	
			13 μm	6.7	170	P167944	Fluorocarbon seal. Compatible with water glycol.
			13 μm	10.7	271	P167945	Fluorocarbon seal. Compatible with water glycol.
			23 μm	6.7	170	P165877	
			23 μm	10.7	271	P165878	
			50 μm	6.7	170	P165879	
		50 μm	10.7	271	P165880		
Water Absorbing		10 μm		10.7	271	P561183	Cellulose media, 3-seal kit. Absorbs 350 ml water.

Filter Notes: * Thread size 11/2"-16 UN.

Head Choices

Port Size	Bypass Rating	Indicator Style & Location	Part No.
1¼" NPT	50 psi / 345 kPa	Visual, Both Sides	P172953
1¼" NPT	25 psi / 172 kPa	Visual, Both Sides	P166418
1¼" NPT	5 psi / 34 kPa	Visual, Both Sides	P166665
SAE-20 O-Ring	25 psi / 172 kPa	Visual, Both Sides	P166439

Note: *Donaldson uses the inlet port as the reference point. "Left side," for instance, means that the indicator mounts on the side of the filter head that is on your left when you face the inlet port.

Service Indicator Options

Use with Bypass Valve Pressure of:	Indicator Part No.	Style ⁽³⁾	Description
Electric Models⁽¹⁾			
15 psi / 103 kPa	P163601	A	Single post DC. Normally open.
25 psi / 172.5 kPa	P163839	A	Single post DC. Normally closed.
25 psi / 172.5 kPa	P162400	A	Single post DC. Normally open.
25 psi / 172.5 kPa	P171143	B	2-wire with Cannon connector. Normally open.
25 psi / 172.5 kPa	P173944	C	3-wire: White = normally open. Red = normally closed. Black = common
50 psi / 276 kPa	P574967	E	DC 2-wire. Normally closed. Gold contacts. Microprocessor compatible.

Service Indicator Options

Use with Bypass Valve Pressure of:	Indicator Part No.	Style ⁽³⁾
Visual Models⁽²⁾		
5 psi / 34.5 kPa	P162694	D
15 psi / 103 kPa	P162642	D
25 psi / 172.5 kPa	P162696	D
N/A	P165984	(blank plate)
25 psi / 172.5 kPa	P575334	H (Visual pop up)
50 psi / 345 kPa	P575335	H (Visual pop up)



Mix and Match

Donaldson's mix and match system provides the great performance and functional advantages of custom-engineered filters with the convenience and speedy delivery of in-stock parts. Choose your options and build an HBK05 filter to suit your specifications.

Indicator Notes: ⁽¹⁾All electric models have a maximum operating temperature of 250°F/ 121°C.

⁽²⁾All visual models have a maximum operating temperature of 180°F/ 82°C. ⁽³⁾See indicator illustrations on facing page.

HBK05 Service Parts

SERVICE PARTS NOTE:
Some service parts may not be stocked. Please contact your Donaldson sales representative for lead time details.

Service Indicator Styles
(See table on opposite page)

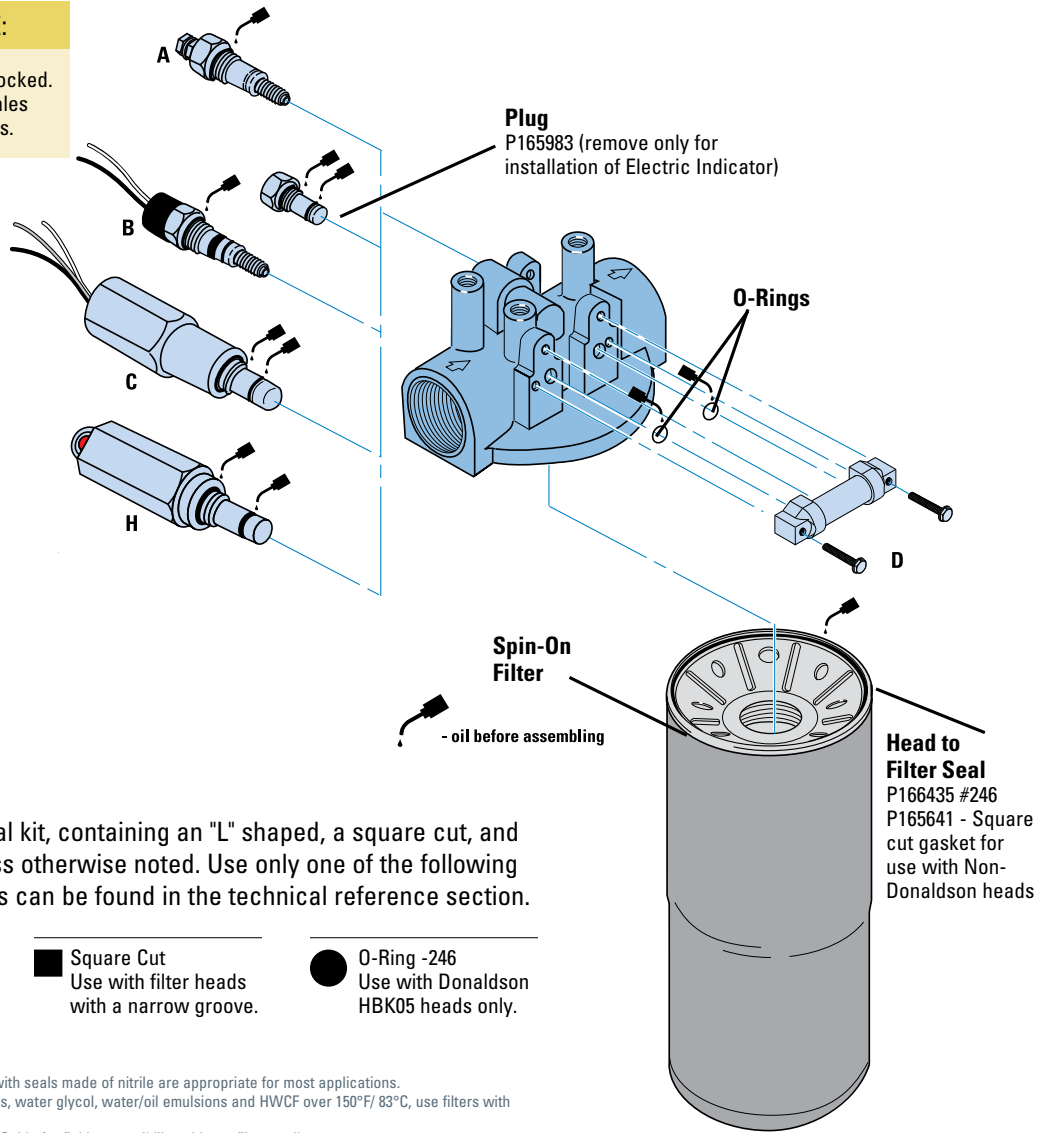

Gaskets

Each filter ships with a 3-seal kit, containing an "L" shaped, a square cut, and an O-Ring gasket seal, unless otherwise noted. Use only one of the following seals. Installation instructions can be found in the technical reference section.

- L Shaped**
Use with filter heads with no groove or a wide groove.
- Square Cut**
Use with filter heads with a narrow groove.
- O-Ring -246**
Use with Donaldson HBK05 heads only.

Filter Notes
 • If you're filtering petroleum-based oil, filters with seals made of nitrile are appropriate for most applications.
 • If you're filtering diester, phosphate ester fluids, water glycol, water/oil emulsions and HWCF over 150°F/ 83°C, use filters with seals made of fluorocarbon.
 • Refer to the table in the Technical Reference Guide for fluid compatibility with our filter media.

Performance Data

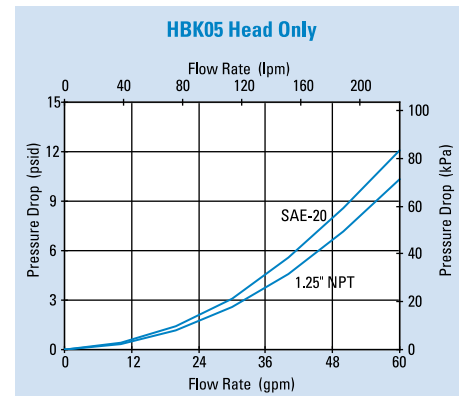
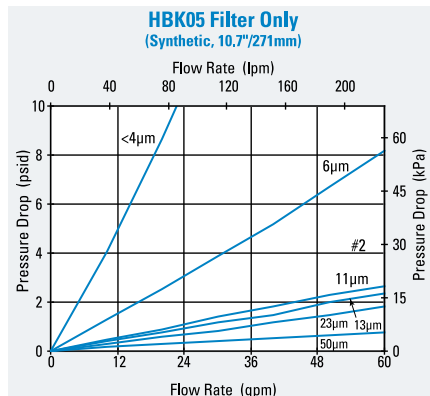
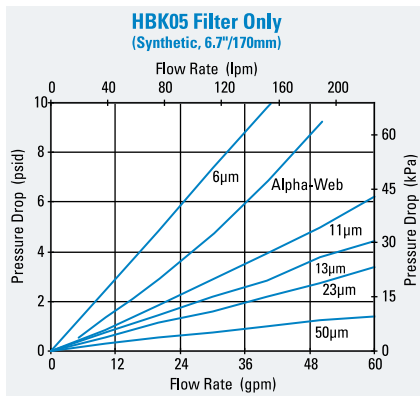



SP50/60

Max Flow: 60 gpm (227 lpm)



SP50/60 Spin-On Filters

Working Pressures to:

150 psi / 1035 kPa / 10.3 bar

Rated Static Burst to:

250 psi / 1725 kPa / 17.2 bar

Flow Range To:

60 gpm / 227 lpm

Features

The SP50/60 spin-on filter is an economical, low-pressure model with a broad selection of media ratings. The die cast aluminum head and steel body ensure strength and durability—perfect for a wide variety of mobile and in-plant applications.

Take advantage of Donaldson's mix and match system of in-stock heads and filter choices—so you can get exactly what you need. Filter options include: synthetic media, natural-fiber cellulose, water-absorbing cellulose media and wire mesh media. SP50/60 spin-on filters are interchangeable with HBK05 filters.

Beta Rating

- Performance to $\beta_{<4(c)}=1000$

Porting Size Options

- 1¼" NPT
- SAE-20 O-Ring

Replacement Filter Lengths

- 6.7" / 170mm
- 7.0" / 178mm
- 10.7" / 271mm

Standard Bypass Ratings

- 25 psi / 172.5 kPa / 1.7 bar
- 15 psi / 103.4 kPa / 1.03 bar
- 5 psi / 34.5 kPa / .34 bar
- No Bypass

Applications

- Fluid Conditioning Systems
- In-Plant Systems
- Mobile Equipment
- Power Transmissions
- Process Systems



Assembly Weight

- 4.7 lbs / 2.1 kg (short)
- 5.6 lbs / 2.5 kg (long)

Operating Temperatures

- -22°F to 225°F / -30°C to 107°C

Filter Collapse Ratings

- 100 psid / 690 kPa / 6.9 bar

SP50/60 Specification Illustrations

ASSEMBLY - SIDE VIEW

All dimensions are shown in inches [millimeters].

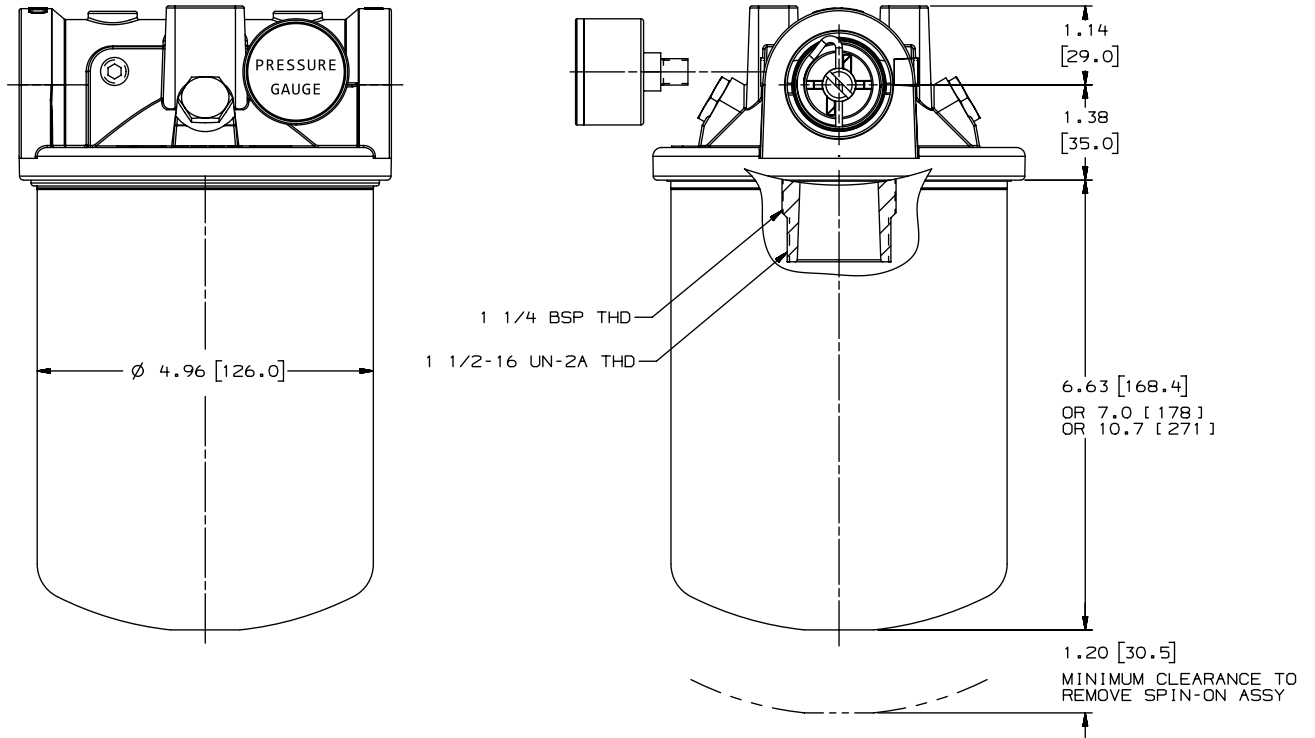

HEAD - TOP VIEW

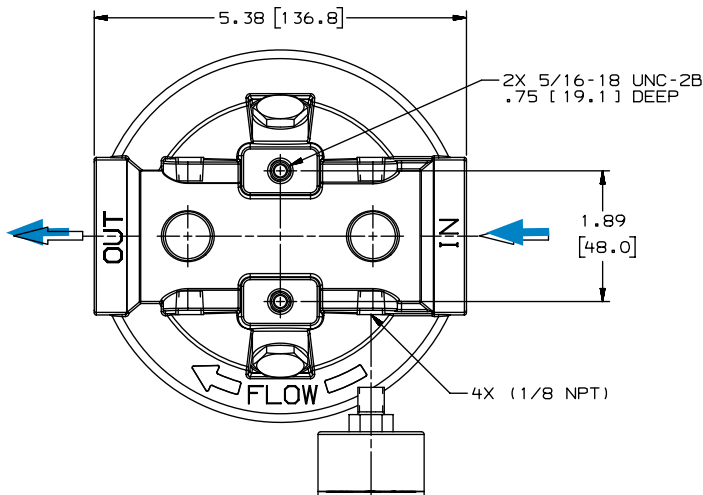



SP50/60

Max Flow: 60 gpm (227 lpm)



SP50/60 Components

Filter Choices

Media Type	$\alpha_{x(c)} = 1000$	$\beta_{x(c)} = 2$	$\beta_{x(c)} = 1000$	Length		Part No.	Comments
	Rating based on ISO 23369	Rating based on ISO 16889		in	mm		
Synteq Synthetic			<4 μm	10.7	271	P167796	Fluorocarbon O-Ring & square seal kit. Compatible with water glycol.
			6 μm	6.7	170	P167162	3-seal kit
			6 μm	10.7	271	P165762	3-seal kit
Alpha-Web	10 μm			6.7	170	DBH5875	3-seal kit
Synteq Synthetic			11 μm	6.7	170	P165875	3-seal kit
			11 μm	10.7	271	P165876	3-seal kit
			13 μm	6.7	170	P167944	Fluorocarbon O-Ring & square seal kit. Compatible with water glycol.
			13 μm	10.7	271	P167945	Fluorocarbon O-Ring & square seal kit. Compatible with water glycol.
			23 μm	6.7	170	P165877	3-seal kit
			23 μm	10.7	271	P165878	3-seal kit
			50 μm	6.7	170	P165879	3-seal kit
			50 μm	10.7	271	P165880	3-seal kit
Cellulose		5 μm		6.7	170	P550386	3-seal kit
		5 μm		10.7	271	P550250	3-seal kit
		7 μm		7.2	183	P550388	3-seal kit
		7 μm		10.7	271	P550251	3-seal kit
		7 μm		7.00	178	P565245	Square seal kit, 1/4" BSP thread
		17 μm		6.7	170	P550387	3-seal kit
		17 μm		10.7	271	P550252	3-seal kit
		27 μm		7.00	178	P171616	Square seal kit, 1/4" BSP thread
Water Absorbing		10 μm		10.7	271	P561183	Cellulose media, 3-seal kit. Absorbs 350 ml water.
Wire Mesh		150 μm		6.7	170	P550275	Stainless steel wire mesh, 3-seal kit
		150 μm		10.7	271	P550276	Stainless steel wire mesh, 3-seal kit

All models have 1 1/2-16 UNF threads except where otherwise noted. All models measure 5.0/127mm outer diameter.

Head Choices

Port Size	Bypass Rating	Gauge Ports (drill, tap, plug)	Gauge Port Location	Part No.
1/4" NPT	No Bypass	(4) 1/8" NPT	upstream and downstream side	P576558
1/4" NPT	5 psi / 34.5 kPa / .34 bar	(4) 1/8" NPT	upstream and downstream side	P576555
1/4" NPT	15 psi / 103.4 kPa / 1.34 bar	(4) 1/8" NPT	upstream and downstream side	P576556
1/4" NPT	25 psi / 172.5 kPa / 1.72 bar	(4) 1/8" NPT	upstream and downstream side	P576557
SAE-20	No Bypass	(4) 1/8" NPT	upstream and downstream side	P576565
SAE-20	5 psi / 34.5 kPa / .34bar	(4) 1/8" NPT	upstream and downstream side	P576562
SAE-20	15 psi / 103.4 kPa / 1.34 bar	(4) 1/8" NPT	upstream and downstream side	P576563
SAE-20	25 psi / 172.5 kPa / 1.72 bar	(4) 1/8" NPT	upstream and downstream side	P576564

Gaskets

Each filter ships with a 3-seal kit, containing an "L" shaped, a square cut, and an O-Ring gasket seal, unless otherwise noted. Use only one of the following seals. Installation instructions can be found in the technical reference section.

- L Shaped**
Use with filter heads with no groove or a wide groove.
- Square Cut**
Use with filter heads with a narrow groove.
- O-Ring -246**
Use with Donaldson HBK05 heads only.

Note: On a return line system the gauge port should be on the upstream side. We suggest a 25 psi bypass. If head is used on a suction line, the gauge port should be on the downstream side very low bypass.

Pressure Gauges

Part No.	Pressure Range	Use With Bypass Valve Rating	Type
P563978	5 to 30 psi field adj.*	15 psi / 103.4 kPa / 1.34 bar or 25 psi / 172.5 kPa / 1.72 bar or No Bypass	Return indicator, electrical
P579714	0 to 100 psi	15 psi / 103.4 kPa / 1.34 bar or 25 psi / 172.5 kPa / 1.72 bar or No Bypass	Return indicator, numeric scale
P579715	0 to 100 psi	15 psi / 103.4 kPa / 1.34 bar Bypass	Return indicator, color coded
P579716	0 to 100 psi	25 psi / 172.5 kPa / 1.72 bar or No Bypass	Return indicator, color-coded
P579717	0 to -30 Hg	5 psi / 34.5 kPa / .34 bar or No Bypass	Suction indicator, numeric scale

* NOT PRESET: Setting adjustable for desired application

P563978

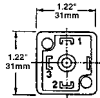

#1 Common; #2 Normally Closed;
#3 Normally Open

Instructions

1. Remove DIN adaptor
2. Remove small brass screw
3. Using 1/8" allen wrench adjust clockwise to increase set point/counter-clockwise to decrease set point
4. NO / NC

Adjustment screw located in center of electric prongs

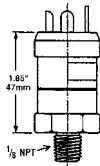

P579714 - P579717

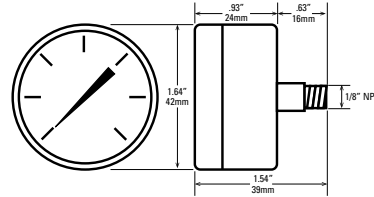

Pop-up Visual Indicators

Use With Bypass Valve Rating	Part Number	Style	Description
25 PSI / 172.5 kPa	P575334	H	Visual Pop-up, Auto Reset
15 PSI / 103 kPa	P579215	H	Visual Pop-up, Auto Reset

Electrical Indicators

Use With Bypass Valve Rating	Part Number	Style	Description
15 PSI / 103 kPa	P163601	A	Single Post DC, Normally Open
25 PSI / 172.5 kPa	P163839	A	Single Post DC, Normally Closed
25 PSI / 172.5 kPa	P162400	A	Single Post DC, Normally Open

Performance Data

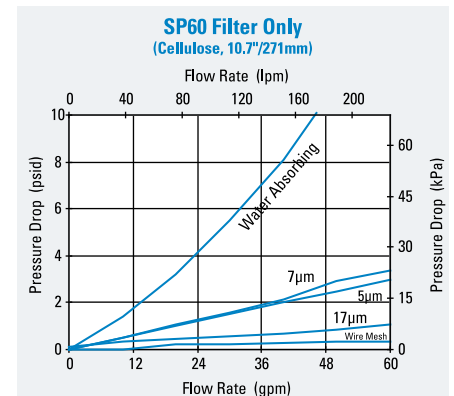
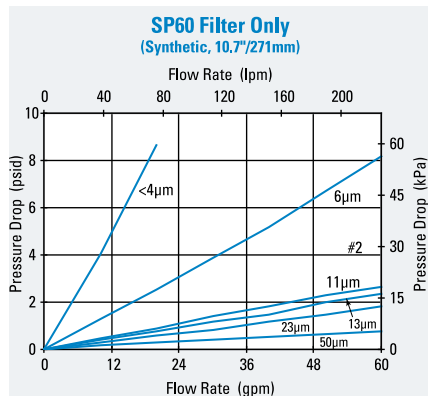
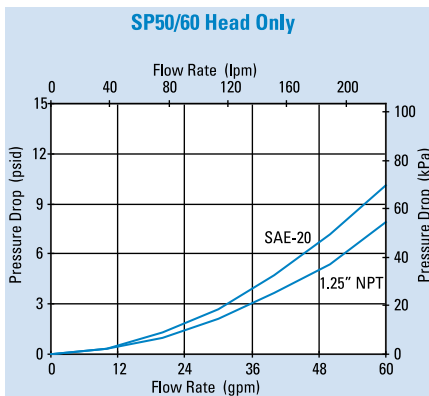
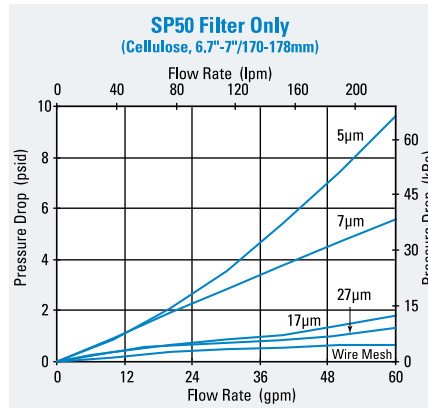
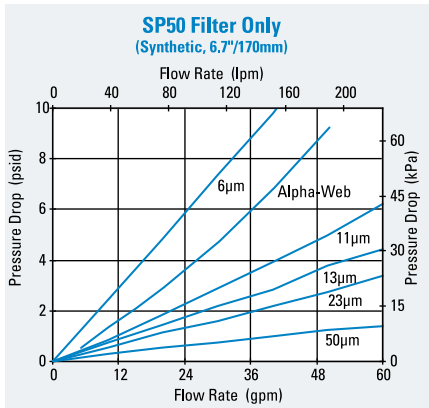



SP80/90

Max Flow: 100 gpm (379 lpm)



SP80/90 Spin-On Filters

Working Pressures to:

150 psi / 1035 kPa / 10.3 bar

Rated Static Burst to:

250 psi / 1725 kPa / 17.2 bar

Flow Range To:

100 gpm / 379 lpm

Features

SP80/90 double filter head allows for double the flow capacity, with two filters to hold more contaminant. Aluminum casting and nitrile seals standard. SP80/90 filters are interchangeable with SP50/60 filters.

Beta Rating

- Performance to $\beta_{<4(c)}=1000$

Porting Size Options

- 1½" NPT
- SAE-24 O-Ring
- 2" SAE 4-Bolt Flange Code 61

Replacement Filter Lengths

- 6.7" / 170mm
- 7.0" / 178mm
- 10.7" / 271mm

Standard Bypass Ratings

- 25 psi / 172.5 kPa / 1.72 bar
- 15 psi / 103.4 kPa / 1.34 bar
- 5 psi / 34.5 kPa / .34 bar
- no bypass

Applications

- Fluid Conditioning Systems
- In-Plant Systems
- Mobile Equipment
- Power Transmissions
- Process Systems



Assembly Weight

- 10.0 lbs / 4.5 kg (short) - approximate
- 11.8 lbs / 5.4 kg (long)

Operating Temperatures

- -22°F to 225°F / -30°C to 107°C

Filter Collapse Ratings

- 100 psid / 690 kPa / 6.9 bar

SP80/90 Specification Illustrations

ASSEMBLY - SIDE VIEW

All dimensions are shown in inches [millimeters].

Combination

**1½" NPT and 2" SAE 4-Bolt Flange (Both Ends)
or SAE-24 (Both Ends)**

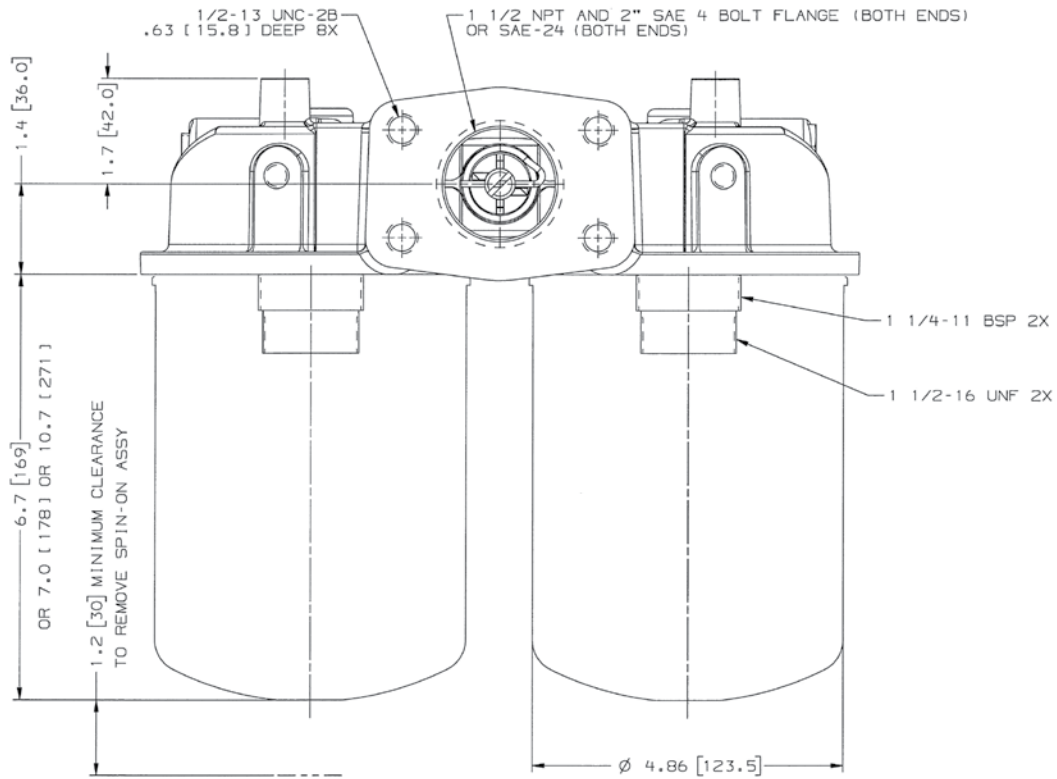

HEAD - TOP VIEW

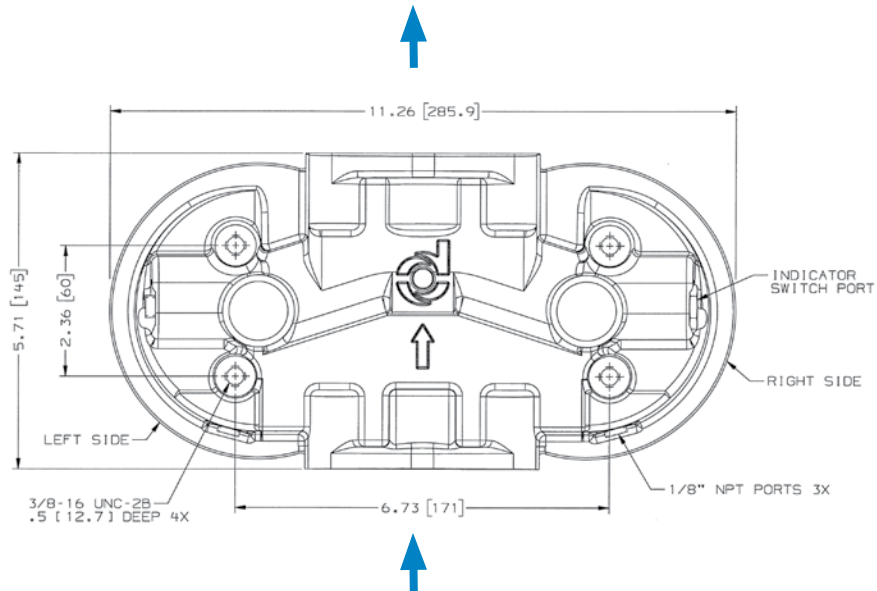



SP80/90

Max Flow: 100 gpm (379 lpm)



SP80/90 Components

Filter Choices

Media Type	$\alpha_{x(c)} = 1000$	$\beta_{x(c)} = 2$	$\beta_{x(c)} = 1000$	Length		Part No.	Comments
	Rating based on ISO 23369	Rating based on ISO 16889		in	mm		
Synteq Synthetic			<4 μm	10.7	271	P167796	Fluorocarbon O-Ring & square seal kit. Compatible w/ water glycol.
			6 μm	6.7	170	P167162	3-seal kit
			6 μm	10.7	271	P165762	3-seal kit
Alpha-Web	10 μm			6.7	170	DBH5875	3-seal kit
Synteq Synthetic			11 μm	6.7	170	P165875	3-seal kit
			11 μm	10.7	271	P165876	3-seal kit
			13 μm	6.7	170	P167944	Fluorocarbon O-Ring & square seal kit. Compatible w/ water glycol.
			13 μm	10.7	271	P167945	Fluorocarbon O-Ring & square seal kit. Compatible w/ water glycol.
			23 μm	6.7	170	P165877	3-seal kit
			23 μm	10.7	271	P165878	3-seal kit
			50 μm	6.7	170	P165879	3-seal kit
			50 μm	10.7	271	P165880	3-seal kit
Cellulose		5 μm		6.7	170	P550386	3-seal kit
		5 μm		10.7	271	P550250	3-seal kit
		7 μm		7.2	183	P550388	3-seal kit
		7 μm		10.7	271	P550251	3-seal kit
		7 μm		7.00	178	P565245	Square seal kit, 1/4" BSP thread
		17 μm		6.7	170	P550387	3-seal kit
		17 μm		10.7	271	P550252	3-seal kit
		27 μm		7.00	178	P171616	Square seal kit, 1/4" BSP thread
Water Absorbing		10 μm		10.7	271	P561183	Cellulose media, 3-seal kit. Absorbs 350 ml water.
Wire Mesh		150 μm		6.7	170	P550275	Stainless steel wire mesh, 3-seal kit
		150 μm		10.7	271	P550276	Stainless steel wire mesh, 3-seal kit

All models have 1 1/2-16 UNF threads except where otherwise noted. All models measure 5.07/127mm outer diameter.

Head Choices

Port Size	Bypass Rating	Gauge Ports (drill, tap, plug)	Gauge Port Location	Part No.
1 1/2" NPT & 2" SAE 4 Bolt	15 psi / 103.4 kPa / 1.34 bar	(4) 1/8" NPT	upstream & downstream sides	P563273
1 1/2" NPT & 2" SAE 4 Bolt	25 psi / 172.5 kPa / 1.72 bar	(4) 1/8" NPT	upstream & downstream sides	P563274
1 1/2" NPT & 2" SAE 4 Bolt	No Bypass	(4) 1/8" NPT	upstream & downstream sides	P563275
1 1/2" NPT & 2" SAE 4 Bolt	5 psi / 34.5 kPa / .34 bar	(4) 1/8" NPT	upstream & downstream sides	P563276
SAE-24 O-Ring	25 psi / 172.5 kPa / 1.72 bar	(4) 1/8" NPT	upstream & downstream sides	P564892
SAE-24 O-Ring	No Bypass	(4) 1/8" NPT	upstream & downstream sides	P573217

Note: On a return line system the gauge port should be on the upstream side. We suggest a 25 psi bypass. If head is used on a suction line, the gauge port should be on the downstream side very low bypass.

Gaskets

Each filter ships with a 3-seal kit, containing an "L" shaped, a square cut, and an O-Ring gasket seal, unless otherwise noted. Use only one of the following seals. Installation instructions can be found in the technical reference section.

- L Shaped
Use with filter heads with no groove or a wide groove.
- Square Cut
Use with filter heads with a narrow groove.
- O-Ring -246
Use with Donaldson HBK05 heads only.

Optional Filter Service Indicators for Left Side

Part No.	Pressure Range	Use With Bypass Valve Rating	Type
P563978	5 to 30 psi field adj.*	15 psi / 103.4 kPa / 1.34 bar or 25 psi / 172.5 kPa / 1.72 bar or No Bypass	Return indicator, electrical
P579714	0 to 100 psi	15 psi / 103.4 kPa / 1.34 bar or 25 psi / 172.5 kPa / 1.72 bar or No Bypass	Return indicator, numeric scale
P579715	0 to 100 psi	15 psi / 103.4 kPa / 1.34 bar Bypass	Return indicator, color coded
P579716	0 to 100 psi	25 psi / 172.5 kPa / 1.72 bar or No Bypass	Return indicator, color-coded
P579717	0 to -30 Hg	5 psi / 34.5 kPa / .34 bar or No Bypass	Suction indicator, numeric scale

P563978

#1 Common; #2 Normally Closed;
#3 Normally Open

Instructions

1. Remove DIN adaptor
2. Remove small brass screw
3. Using 1/8" allen wrench adjust clockwise to increase set point/counter-clockwise to decrease set point
4. NO / NC

Adjustment screw located in center of electric prongs

P579714 - P579717



Notes
* NOT PRESET: Setting adjustable for desired application

Optional Filter Service Indicators for Right Side

Refer to Filter Service Indicators pages of the accessories section for right side electrical filter service indicator options.

Performance Data

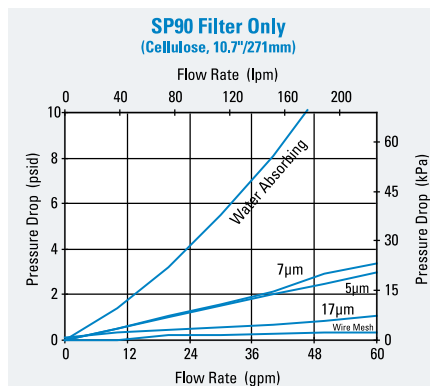
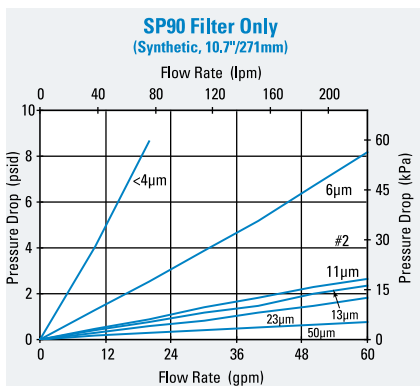
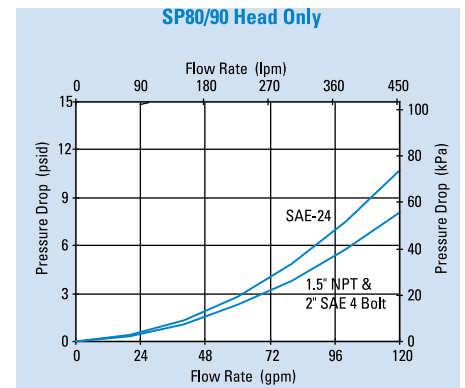
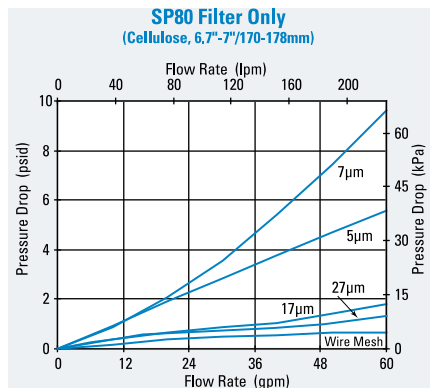
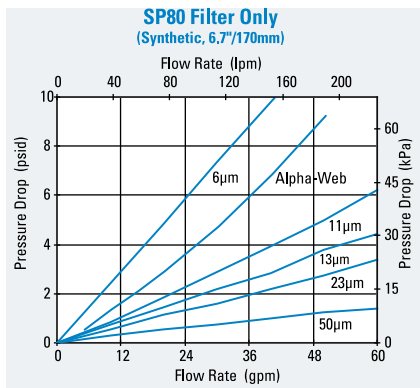



SP100/120

Max Flow: 100 gpm (379 lpm)



SP100/120 Spin-On Filters

Working Pressures to:

150 psi / 1035 kPa / 10.3 bar

Rated Static Burst to:

250 psi / 1725 kPa / 17.2 bar

Flow Range To:

100 gpm / 379 lpm

Features

SP100/120 double filter head allows for double the flow capacity and a unique, space-saving configuration. Aluminum casting and nitrile seals standard. SP100/120 filters are interchangeable with SP50/60 filters.

Applications

- Fluid Conditioning Systems
- In-Plant Systems



Beta Rating

- Performance to $\beta_{<4(c)}=1000$

Porting Size Options

- 1½" NPT

Replacement Filter Lengths

- 6.7" / 170mm
- 7.0" / 178mm
- 10.7" / 271mm

Standard Bypass Ratings

- 25 psi / 172.5 kPa / 1.72 bar

Assembly Weight

- 7.0 lbs / 3.2 kg (short)
- 8.8 lbs / 4.0 kg (long)

Operating Temperatures

- -22°F to 225°F / -30°C to 107°C

Filter Collapse Ratings

- 100 psid / 690 kPa / 6.9 bar

SP100/120 Specification Illustrations

ASSEMBLY - SIDE VIEW

All dimensions are shown in inches [millimeters].

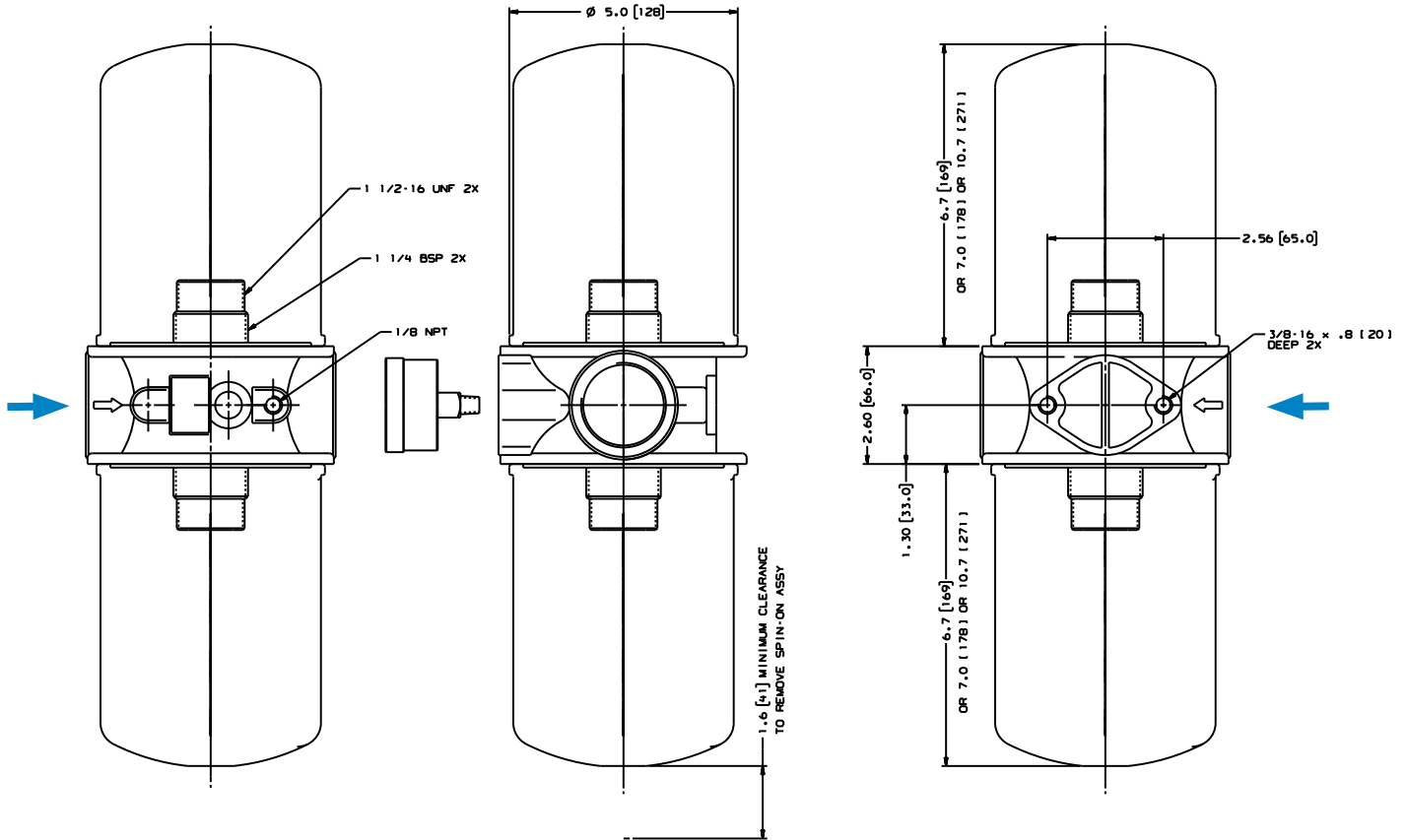



SP100/120

Max Flow: 100 gpm (379 lpm)



SP100/120 Components

Filter Choices

Media Type	$\alpha_{x(c)} = 1000$	$\beta_{x(c)} = 2$	$\beta_{x(c)} = 1000$	Length		Part No.	Comments
	Rating based on ISO 23369	Rating based on ISO 16889		in	mm		
Synteq Synthetic			<4 μm	10.7	271	P167796	Fluorocarbon O-Ring & square seal kit. Compatible with water glycol.
			6 μm	6.7	170	P167162	3-seal kit
			6 μm	10.7	271	P165762	3-seal kit
Alpha-Web	10 μm			6.7	170	DBH5875	3-seal kit
Synteq Synthetic			11 μm	6.7	170	P165875	3-seal kit
			11 μm	10.7	271	P165876	3-seal kit
			13 μm	6.7	170	P167944	Fluorocarbon O-Ring & square seal kit. Compatible with water glycol.
			13 μm	10.7	271	P167945	Fluorocarbon O-Ring & square seal kit. Compatible with water glycol.
			23 μm	6.7	170	P165877	3-seal kit
			23 μm	10.7	271	P165878	3-seal kit
			50 μm	6.7	170	P165879	3-seal kit
			50 μm	10.7	271	P165880	3-seal kit
	Cellulose		5 μm		6.7	170	P550386
		5 μm		10.7	271	P550250	3-seal kit
		7 μm		7.2	183	P550388	3-seal kit
		7 μm		10.7	271	P550251	3-seal kit
		7 μm		6.2	158	P565245	Square seal kit, 1/4" BSP thread
		17 μm		6.7	170	P550387	3-seal kit
		17 μm		10.7	271	P550252	3-seal kit
		27 μm		7.00	178	P171616	Square seal kit, 1/4" BSP thread
Water Absorbing		10 μm		10.7	271	P561183	Cellulose media, 3-seal kit. Absorbs 350 ml water.
Wire Mesh		150 μm		6.7	170	P550275	Stainless steel wire mesh, 3-seal kit
		150 μm		10.7	271	P550276	Stainless steel wire mesh, 3-seal kit

All models have 1/2-16 UNF threads except where otherwise noted. All models measure 5.0/127mm outer diameter.

Head Choice

Port Size	Bypass Rating	Gauge Ports (drill, tap, plug)	Gauge Port Location	Part No.
1/2" NPT	25 psi / 172.5 kPa / 1.72 bar	(2) 1/8" NPT	upstream & downstream sides	P563277

Note: On a return line system the gauge port should be on the upstream side. We suggest a 25 psi bypass. If head is used on a suction line, the gauge port should be on the downstream side very low bypass.

Gaskets

Each filter ships with a 3-seal kit, containing an "L" shaped, a square cut, and an O-Ring gasket seal, unless otherwise noted. Use only one of the following seals. Installation instructions can be found in the technical reference section.

- L Shaped
Use with filter heads with no groove or a wide groove.
- Square Cut
Use with filter heads with a narrow groove.
- O-Ring -246
Use with Donaldson HBK05 heads only.



Optional Filter Service Indicators

This handy pressure gauge, mounted on the side of an SP100/120 filter head, will tell you when it's time to service the filter.

Part No.	Pressure Range	Use With Bypass Valve Rating	Type
P563978	5 to 30 psi field adj.*	15 psi / 103.4 kPa / 1.34 bar or 25 psi / 172.5 kPa / 1.72 bar or No Bypass	Return indicator, electrical
P579714	0 to 100 psi	15 psi / 103.4 kPa / 1.34 bar or 25 psi / 172.5 kPa / 1.72 bar or No Bypass	Return indicator, numeric scale
P579715	0 to 100 psi	15 psi / 103.4 kPa / 1.34 bar Bypass	Return indicator, color coded
P579716	0 to 100 psi	25 psi / 172.5 kPa / 1.72 bar or No Bypass	Return indicator, color-coded
P579717	0 to -30 Hg	5 psi / 34.5 kPa / .34 bar or No Bypass	Suction indicator, numeric scale

P563978

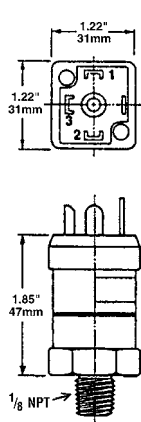

#1 Common; #2 Normally Closed;
#3 Normally Open

Instructions

1. Remove DIN adaptor
2. Remove small brass screw
3. Using 1/8" allen wrench adjust clockwise to increase set point/counter-clockwise to decrease set point
4. NO / NC

Adjustment screw located in center of electric prongs

P579714 - P579717

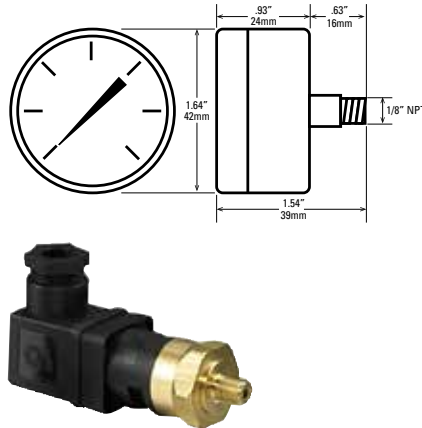

Notes

* NOT PRESET: Setting adjustable for desired application

Performance Data

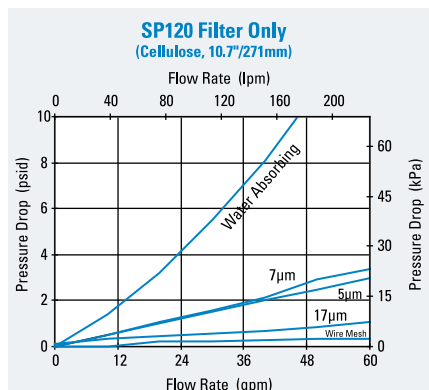
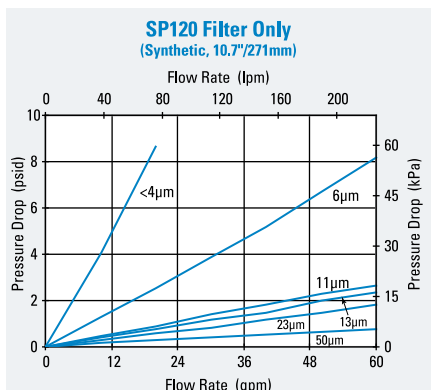
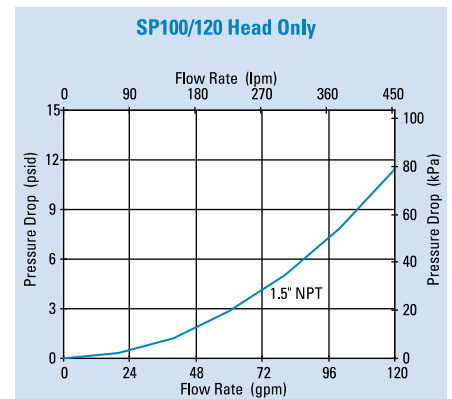
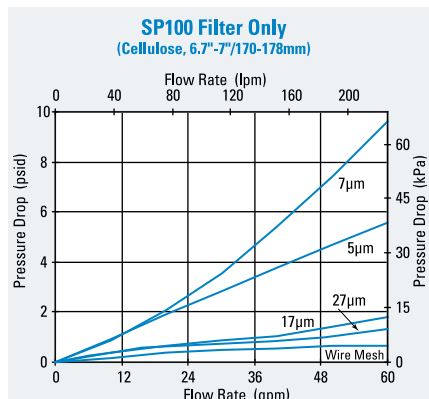
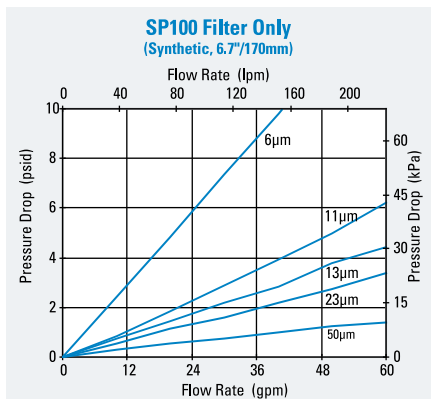



TT15/30/60

Max Flow: 50 gpm (189 lpm)



TT15/30/60 Tank Top Return Spin-On Filters

Working Pressures to:

100 psi / 690 kPa / 6.9 bar

Rated Static Burst to:

250 psi / 1725 kPa / 17.2 bar

Flow Range To:

50 gpm / 189 lpm



Applications

- In-Plant Systems
- Mobile Equipment
- Return Lines



Features

TT15/30/60 Tank Top filters are designed for industrial service. Aluminum casting and nitrile seals standard. Used with mineral and synthetic based fluids, these return filters conveniently mount to tank tops with four screws. Common holes are used to mount the filter head to the reservoir without welding. A down pipe is attached to a threaded port and the gasket surface provides a watertight seal. Each filter provides a new bypass valve and anti-drainback valve for easy filter change.

Beta Rating

- Performance to $\beta_{7(c)}=2$

Porting Size Options

- 3/4", 1 1/2" NPT

Replacement Filter Lengths

- 5.83" / 148mm TT15
- 7.05" / 179mm TT30
- 9.29" / 236mm TT60

Standard Bypass Ratings

- 22 psi / 150 kPa / 1.5 bar

Assembly Weight

- 2.0 lbs / 0.9 kg TT15
- 4.3 lbs / 2.0 kg TT30
- 5.2 lbs / 2.4 kg TT60

Operating Temperatures

- -22°F to 225°F / -30°C to 107°C

Filter Collapse Ratings

- 250 psid / 1725 kPa / 17.2 bar

TT15/30/60 Components

Filter Choices

Media Type	$\beta_{x(c)} = 2$	Length		Part No.	Comments
	Rating based on ISO 16889	in	mm		
Cellulose	7µm	5.36	136	P565242	TT15 Series
	10 µm	7.05	179	P171635	TT30 Series
	10 µm	9.29	236	P171640	TT60 Series

Performance Data

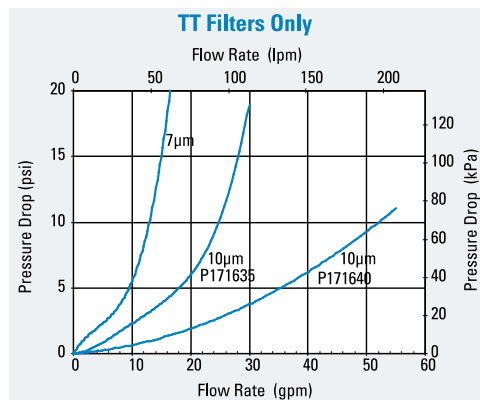

Head Choices

Port Size	Bypass Rating*	Gauge Ports (drill, tap, plug)	Gauge Port Location	Part No.	Description	Head to Tank** Seal Part No.
3/4" NPT	22 psi / 150 kPa / 1.5 bar	(2) 1/8" NPT	upstream side	P564038	TT15 Series	P563975
1 1/2" NPT	22 psi / 150 kPa / 1.5 bar	(2) 1/8" NPT	upstream side	P563973	TT30/60 Series	P563976

Note: * Bypass valve is integral part of replacement filter. ** Included with head. On a return line system the gauge port should be on the upstream side. We suggest a 25 psi bypass. If head is used on a suction line, the gauge port should be on the downstream side very low bypass.

Optional Filter Service Indicators

Part No.	Pressure Range	Use With Series	Type
P563300	0 to 30 psi	TT15/30/60	Return indicator, color-coded
P563978	5 to 30 psi field adj.*	TT15/30/60	Return indicator, electrical
P579716	0 to 100 psi	TT15/30/60	Return indicator, color-coded

P563978

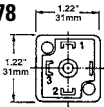

#1 Common; #2 Normally Closed; #3 Normally Open

Instructions

1. Remove DIN adaptor
2. Remove small brass screw
3. Using 1/8" allen wrench adjust clockwise to increase set point/counter-clockwise to decrease set point
4. NO / NC

Adjustment screw located in center of electric prongs

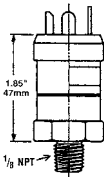

1/8" - 27 NPTF threads

- Built in snubber to minimize damage caused by pressure surges
- Compatible with petroleum and mineral-based fluids
- Anti-splash

Notes: *NOT PRESET: Setting adjustable for desired application

P579716

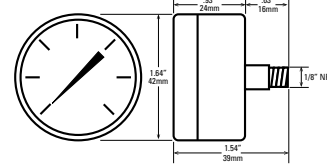

P563300

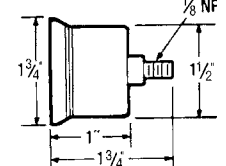

TT 15 & 30/60 Specification Illustrations

ASSEMBLY - SIDE VIEW

All dimensions are shown in inches [millimeters].

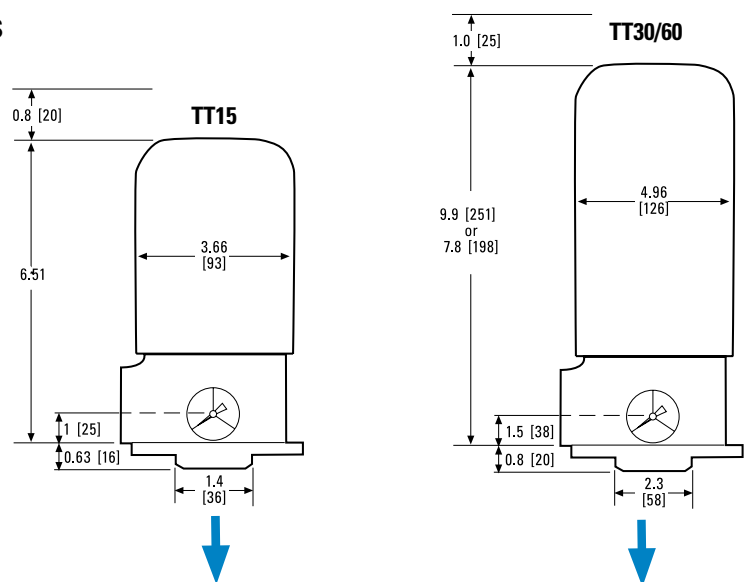

HEAD - TOP VIEW

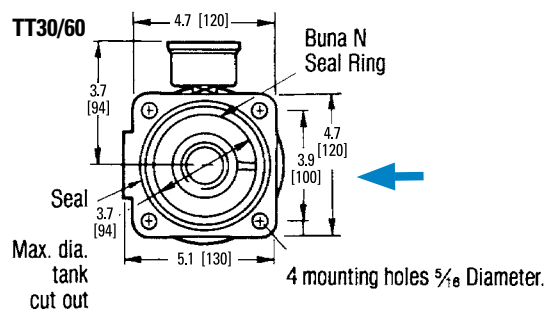
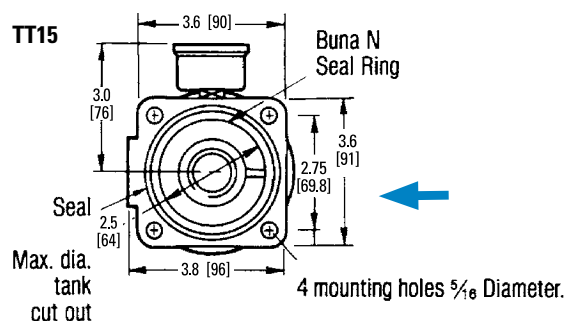



FIS2

Max Flow: 150 gpm (568 lpm)



FIS2 In-Tank Filters

Working Pressures to:

200 psi / 1380 kPa / 13.8 bar

Rated Static Burst to:

300 psi / 2070 kPa / 20.7 bar

Flow Range To:

225 gpm / 852 lpm

Applications

- Cooling Circuits
- Fluid Conditioning Systems
- Lube Oil Systems
- Process Systems
- Return Lines
- Side Loop Systems



Features

FIS2 in-tank filters are economical, durable, and space-saving units. FIS2 filters, featuring a die-cast aluminum head and a bowless design, are designed to handle heavy duty applications. The head (and the inlet) sit above the tank, while the housing remains inside the tank, offering design-in flexibility.

Beta Rating (per ISO 16889)

- Performance to $\beta_{5(c)}=1000$

Porting Size Options

- (1) 1½" Code 61 Flange with Metric Threads
- (2) 1½" Code 61 Flange with Metric Threads
- (1) 2" Code 61 Flange with Metric Threads and 1½" SAE-ORB
- (2) 2" Code 61 Flange with Metric Threads and 1½" SAE-ORB
- (1) 2" Code 61 Flange with Metric Threads and 1½" G thread (BSPP)
- (2) 2" Code 61 Flange with Metric Threads and 1½" G Thread (BSPP)

Replacement Filter Lengths

- 8" / 200mm
- 11" / 280mm
- 18" / 460mm
- 27" / 690mm

Standard Bypass Ratings

- 25 psi / 172.5 kPa / 1.72 bar
- 50 psi / 345 kPa / 3.5 bar

Operating Temperatures

- -45° to 250°F (-43° to 121°C)

Filter Collapse Ratings

- 150 psid / 1035 kPa / 10.3 bar

Performance Data

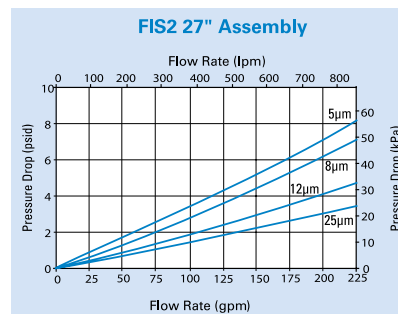
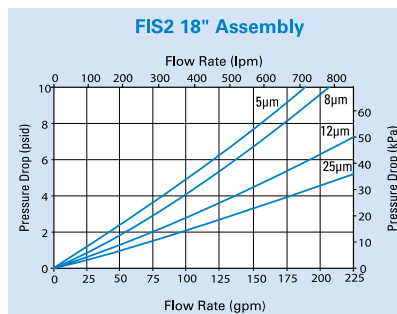
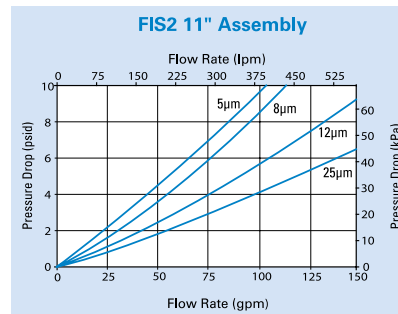
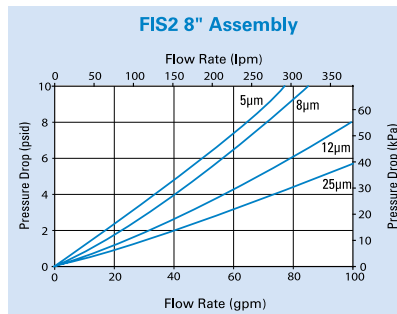

Designed with Features for Application Flexibility, Improved Servicing and Enhanced Filtration Performance

STYLE B SHOWN BELOW

Clean and Easy Servicing

- Inside-out flow, contaminants stay with element when servicing
- Thread in cover
- Hex nut or screwdriver lid removal

Durable Head Casting

- High pressure aluminum die cast head

Weld Flange

- Optional weld flange available

Filter Media Technology

Inside-out flow limits aeration, allowing you to use a smaller reservoir than you would with traditional return filters

Inside-out flow helps keep contaminants inside element even under cold start conditions and maintenance procedures

Wide range of Donaldson media offerings to meet various performance targets and cleanliness standard

Flexible Mounting Configurations

2 or 4 hole mounting option

- Weld flange available
- Better sealing and stability
- Enhanced stability on plastic tanks
- Reverse compatible-retrofit existing tanks with the new hole configuration

Flat Gasket Design

- Better sealing and stability

Built-In Bypass Valve

- New bypass valve installed with every filter replacement

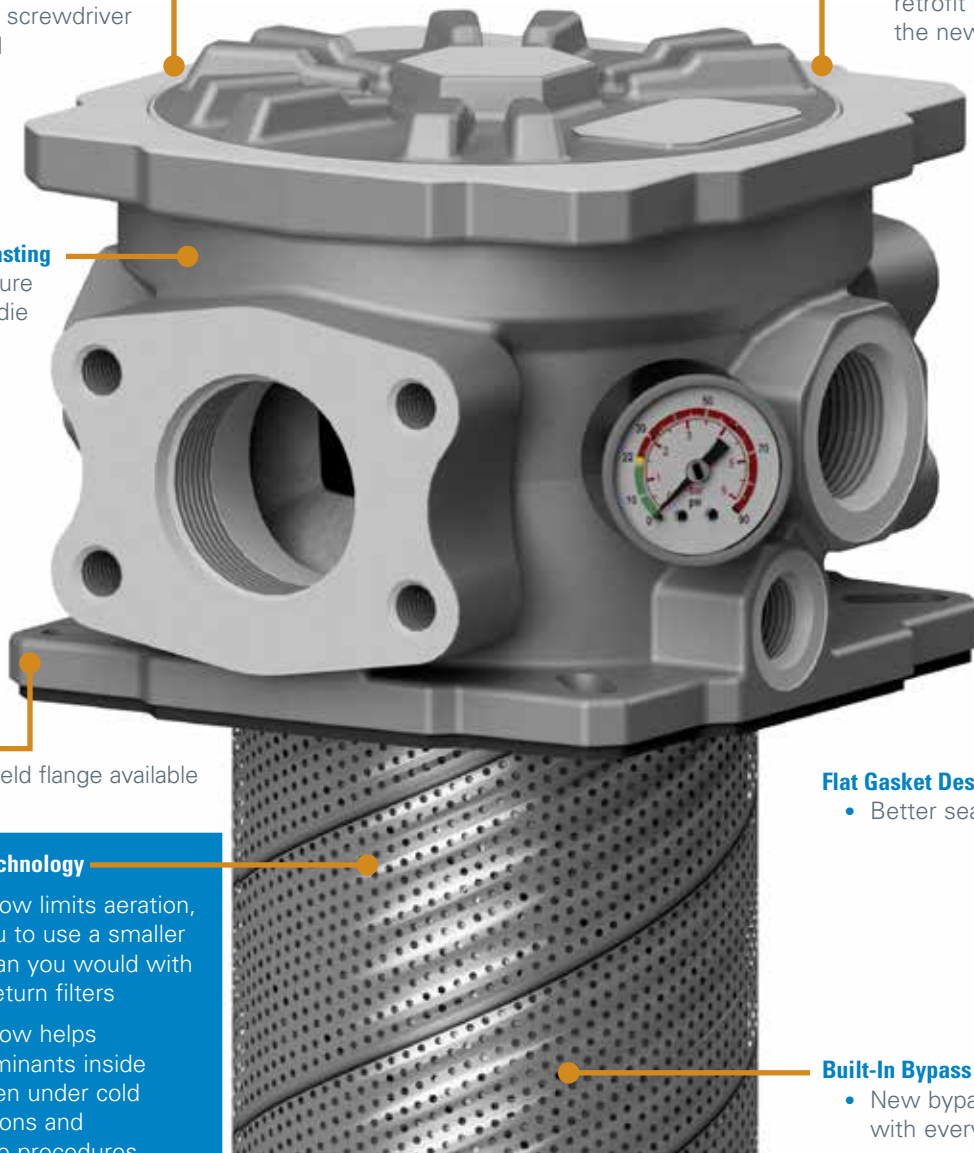



FIS2 Components

Filter Choices

Media Type	$\beta_{x(c)} = 1000$	Length		Bypass	Part No.	
	Rating based on ISO 16889	in	mm			
DT Synthetic	5 μ m	8	200	25 psid (1.7 bar)	P584197	
	8 μ m				P584198	
	12 μ m				P584199	
	25 μ m				P584200	
	5 μ m	11	280		P584201	
	8 μ m				P584202	
	12 μ m				P584203	
	25 μ m				P584204	
	5 μ m	18	460		P584205	
	8 μ m				P584206	
	12 μ m				P584207	
	25 μ m				P584208	
	5 μ m	27	690		P584209	
	8 μ m				P584210	
	14 μ m				P584211	
	25 μ m				P584212	
	5 μ m	8	200		50 psid (3.4 bar)	P584213
	8 μ m					P584214
	12 μ m					P584215
	25 μ m					P584216
	5 μ m	11	280			P584217
	8 μ m					P584218
	12 μ m					P584219
	25 μ m					P584220
	5 μ m	18	460			P584221
	8 μ m					P584222
	12 μ m					P584223
	25 μ m					P584224
5 μ m	27	690	P584225			
8 μ m			P584226			
14 μ m			P584227			
25 μ m			P584228			

Indicator Choices

Indicator Pressure Setting	Connector Style	Part No.
Visual Pressure Gauges, 0-60 psi		
25 psi / 172 kPa	NA	X011059
50 psi / 345 kPa	NA	X011075
Visual Pressure Gauges, 0-200 psi		
50 psi / 345 kPa	NA	X011060
Electrical Service Indicator		
25 psi / 172 kPa	Hirschman (DIN 43650)	X220879
25 psi / 172 kPa	3-Wire	X220880
50 psid / 345 kPa	Hirschman (DIN 43650)	X220882
50 psid / 345 kPa	3-Wire½	X220883
Adapter		
BSPP Indicator Adapter	1/8" NPT to 1/8" BSPP (G Thread)	P584237

Service Part Choices

Description	Part No.
4-Bolt Weld Flange	X220873
FIS2 Cover, Cover Nitrile Seal, Adapter, Adapter Nitrile Seal	X220874
Flat Reservoir Nitrile Gasket	X220875
Nitrile Seal Kit (Cover & Adapter)	X220876
Fluorocarbon Seal Kit (Cover, Adapter, & Element)	X220877
Flat Reservoir Fluorocarbon Gasket	X220878

Head Choices

Port Size	Seal Material	Indicator Style and Location	Part No.
(1) 1½" Code 61 Flange	Nitrile	Port Machined and Plugged	P584231
(2) 1½" Code 61 Flange	Nitrile	Port Machined and Plugged	P584232
(1) 2" Code 61 Flange with 1½" SAE-ORB	Nitrile	Port Machined and Plugged	P584233
(2) 2" Code 61 Flange and 1½" SAE-ORB	Nitrile	Port Machined and Plugged	P584234
(1) 2" Code 61 Flange with 1½" G Thread (BSPP)	Nitrile	Port Machined and Plugged	P584235
(2) 2" Code 61 Flange with 1½" G Thread (BSPP)	Nitrile	Port Machined and Plugged	P584236

FIS2 Components

Dimension Table

Length	8		18		27	
	in	mm	in	mm	in	mm
A	8.18	207.8	19.22	488.2	27.20	690.9
B	8.68	220.5	18.72	500.9	27.70	703.6
C	0.88	22.4	0.88	22.4	0.88	22.4
D	2.39	60.6	2.39	60.6	2.39	60.6
E	5.17	131.3	5.17	131.3	5.17	131.3
F	0.25	6.4	0.25	6.4	0.25	6.4
G	0.61	15.5	0.61	15.5	0.61	15.5
H	15.37	390.4	26.41	670.8	34.36	872.7

FIS2 Specification Illustrations

HEAD - TOP VIEW

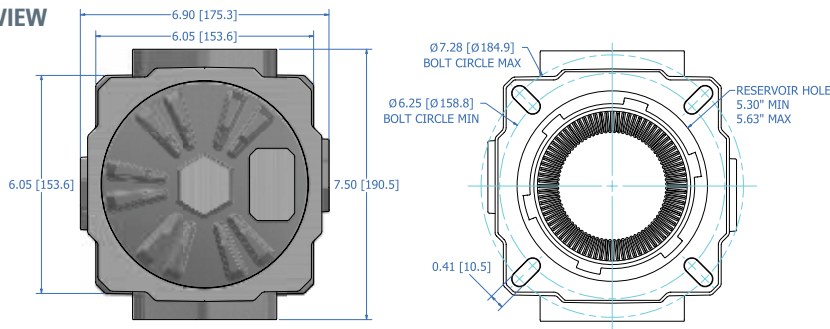

ASSEMBLY - SIDE VIEW

All dimensions are shown in millimeters [inches].

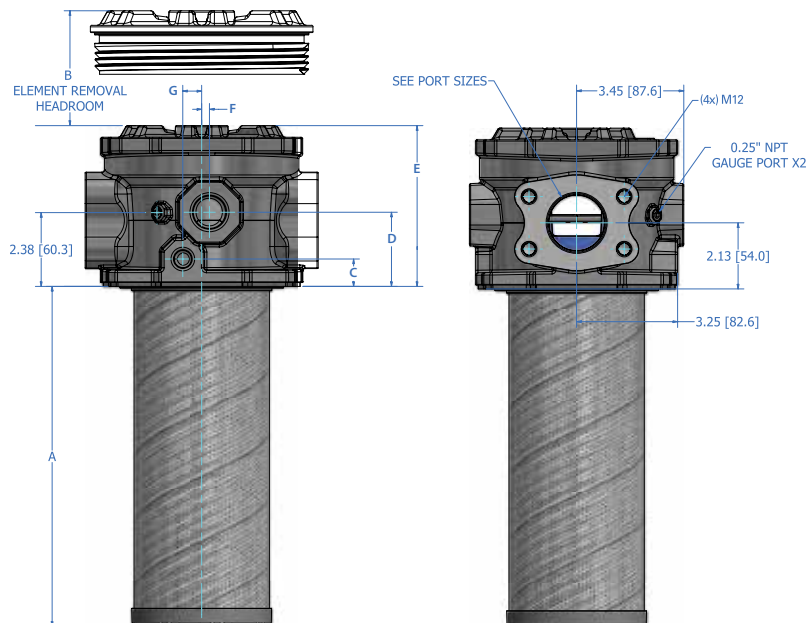



FISB

Max Flow: 70 gpm (265 lpm)



FISB In-Tank Return Line Filter Assemblies

Working Pressures to:

150 psi / 1035 kPa / 10.3 bar

Rated Static Burst to:

100 psi / 2070 kPa / 20.7 bar

Flow Range To:

70 gpm / 265 lpm

Applications

- Cooling Circuits
- Fluid Conditioning Systems
- Lube Oil Systems
- Process Systems
- Return Lines
- Side Loop Systems



Features

Donaldson FISB in-tank filter assemblies are ideal for mobile and industrial power unit hydraulic applications where the breather integrated into the filter head can save space to yield a compact solution.

Operating Temperatures

- -20° to 250°F (-429° to 121°C)

Pressure Switch Trigger

- 18 psi (1.2 bar) or 35 psi (2.4 bar)

Visual Gauge

- 0-100 psi, no color code
- 15 psi, green to red
- 25 psi, green to red

Element Burst Rating

- 100 psid (6.9 bard)

Materials of Construction

- **Head:** Cast aluminum
- **Cover and Breather:** Nylon glass-filled
- **Element Bypass Valve** Plated steel

Integral Bypass Setting

- 25 psid (1.7 bard) or 50 psid (3.2 bard)

Performance Data

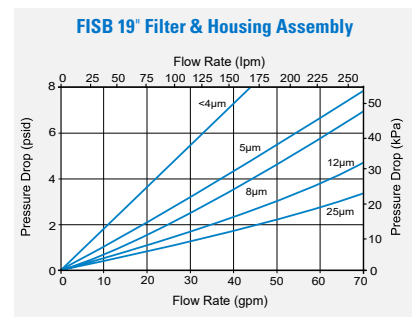
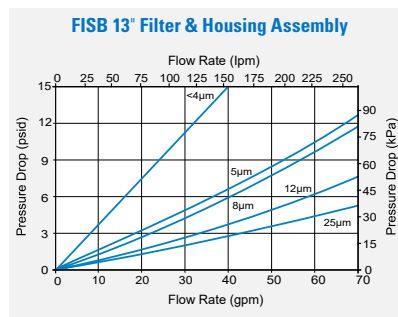
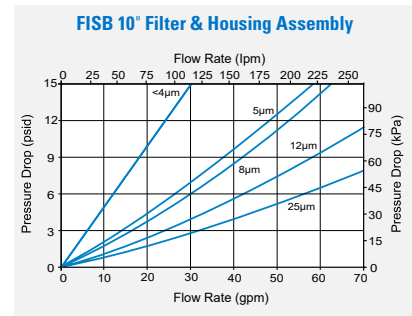
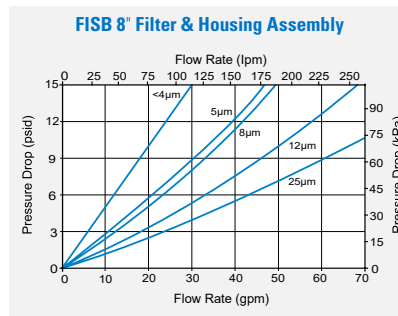

Filter Choices

Media Type	$\beta_{x(c)} = 1000$ Rating based on ISO 16889	Length		Bypass	Part No.	
		in	mm			
DT Synthetic	<4 μ m	8	200	25 psid (1.7 bar)	P583635	
	5 μ m				P583636	
	8 μ m				P583637	
	12 μ m				P583638	
	23 μ m				P583639	
	5 μ m	10	250		P583641	
	8 μ m				P583642	
	12 μ m				P583643	
	23 μ m				P583644	
	5 μ m	13	330		P583646	
	8 μ m				P583647	
	12 μ m				P583648	
	23 μ m				P583649	
	5 μ m	19	480		P583651	
	8 μ m				P583555	
	12 μ m				P583652	
	23 μ m				P583653	
	5 μ m	8	200		50 psid (3.4 bar)	P583655
	8 μ m					P583656
	12 μ m					P583657
	23 μ m					P583658
	5 μ m	10	250			P583660
	8 μ m					P583661
	12 μ m					P583662
	23 μ m					P583663
	5 μ m	13	330			P583665
	8 μ m					P583666
	12 μ m					P583667
23 μ m	P583668					
5 μ m	19	480	P583670			
8 μ m			P583671			
12 μ m			P583672			
23 μ m			P583673			

Head Choices

Connection	Breather	Port	Indicator	Seals	Part No.
SAE-20, O-ring	Plug	1.25" SAE	None	Flouorocarbon	P583554
SAE-16, O-ring	Plug	1.0" SAE	None	Flouorocarbon	P583634





FISB

Max Flow: 70 gpm (265 lpm)



Indicators and Gauges



Description	Part Number	Indicator Pressure	Connection
Electrical Indicator	X011066	35 psi	Brad Harrison
Electrical Indicator	X011065	18 psi	Brad Harrison
Electrical Indicator	X011064	35 psi	Hirschman
Electrical Indicator	X011061	18 psi	Hirschman
Pressure Indicator	X011059	25 psi	Dial Gauge
Pressure Indicator	X011075	50 psi	Dial Gauge
Pressure Gauge	P579716	0-100 psi	Color Dial Gauge 25 psid
Pressure Gauge	P579714	0-100 psi	Dial Gauge

T.R.A.P.™ Breather Choice



For Redesigned Style B Assemblies with 4 Hole Mounting Configurations Only

Note: T.R.A.P. breathers are not compatible on older style assemblies with 2 hole mounting configuration

Part No.	Description	Efficiency	Fits Assembly Models:
STYLE B			
 P766528	Black Standard plug (no air exchange)	N/A	FISB
 P766530	Blue Atmospheric pressure	10 µm @ 98%	FISB

Service Part Choice

Description	Part No.
4-Bolt Weld Flange	X220872

FISB Specification Illustrations

Dimension Table

Length	8		10		13		19	
	in	mm	in	mm			in	mm
A	8.0	200.0	10.0	250.0	13.0	330.0	19.0	480.0
B	8.5	212.7	10.5	266.7	13.5	342.9	19.5	495.3

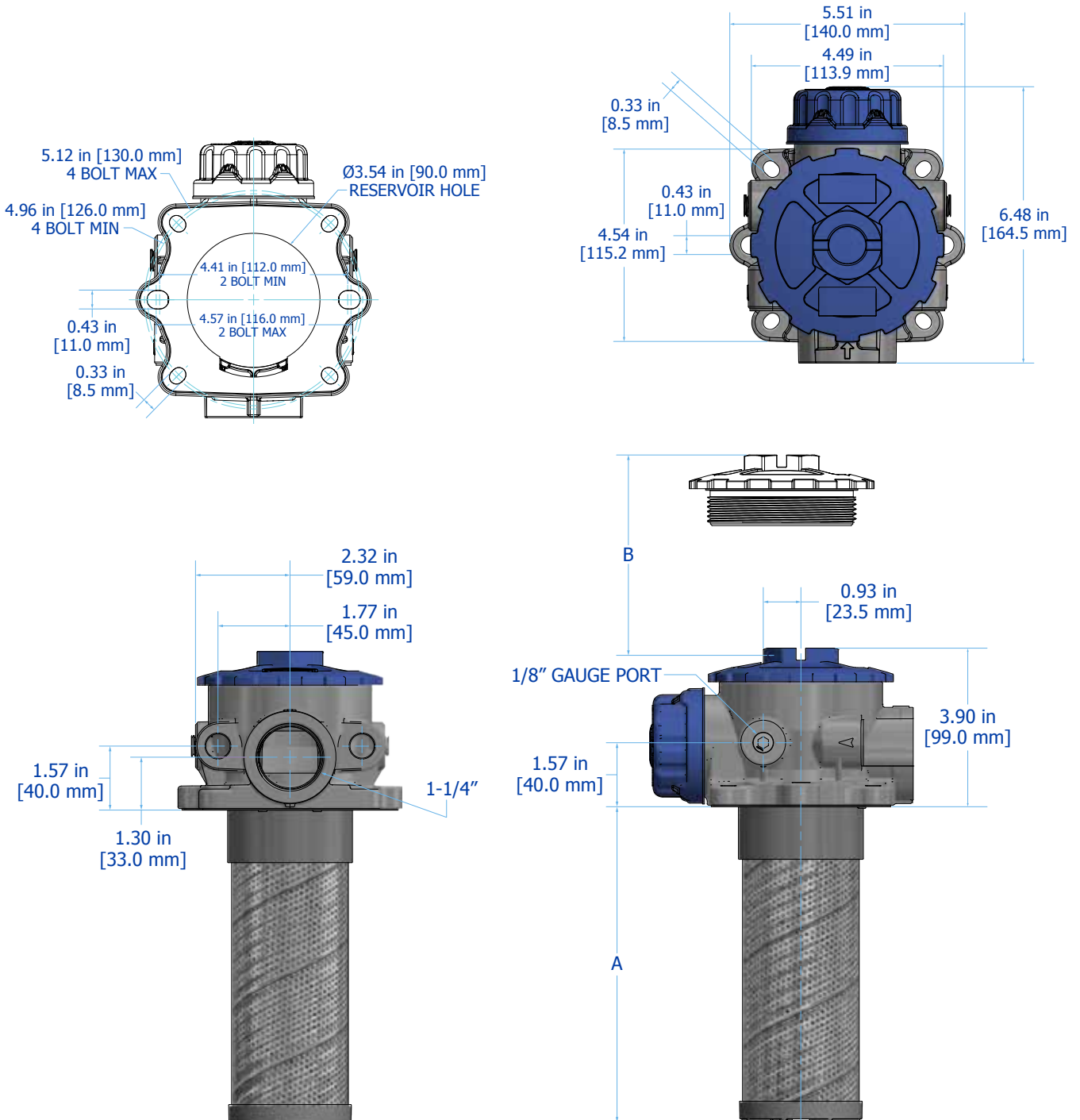



FIK

Max Flow: 170 gpm (644 lpm)



FIK In-Tank Filters

Working Pressures to:

145 psi / 1000 kPa / 10 bar

Rated Static Burst to:

217 psi / 1500 kPa / 15 bar

Flow Range To:

170 gpm / 644 lpm

Applications

- Cooling Circuits
- Fluid Conditioning Systems
- Lube Oil Systems
- Process Systems
- Return Lines
- Side Loop Systems



Features

FIK in-tank filters are economical, space-saving units offering a variety of options including aluminum or plastic access covers, mounting options, and breathers. FIK filters, featuring a die-cast aluminum head and a steel or plastic canister are designed to handle heavy-duty applications. The head (and the inlet) sit above the tank, while the housing remains inside the tank, offering design-in flexibility. Optional air breather featuring T.R.A.P.™ technology are available with style A and B, designed to allow the breather to be mounted directly in the FIK filter head, thus eliminating the cost associated with an additional penetration to the hydraulic tank for breather installation. FIK filters offer three service indicators to choose from: pressure gauge, visual indicator and electrical indicator. FIK filter assemblies are shipped from the factory with cellulose or Synteq™ synthetic filter media, and replacement cartridges are offered in a range of media types and performance ratings.

Beta Rating

- Performance to $\beta_{8(c)}=1000$

Porting Size Options

- ½", ¾", 1" NPT
- SAE-8, SAE-12, SAE-16, SAE-20, SAE-24 O-Ring
- 2" SAE 4-Bolt Flange Code 61

Standard Bypass Ratings

- 22 psi / 150 kPa / 1.5 bar

Operating Temperatures

- -4°F to 194°F / -20°C to 90°C

Filter Collapse Ratings

- 145 psid / 1000 kPa / 10 bar

Redesigned with Features for Application Flexibility, Improved Servicing and Enhanced Filtration Performance

STYLE B SHOWN BELOW

Multifunctional Ports (custom)

Contact your Donaldson sales representative for details

- Can be converted into auxiliary inlet ports
- The two secondary inlet ports can be used in conjunction with the main inlet port for higher flow rates

Flat Gasket Design

- For leak-tight operation

Service Indicator Ports

- Electrical, visual or pressure gauge options

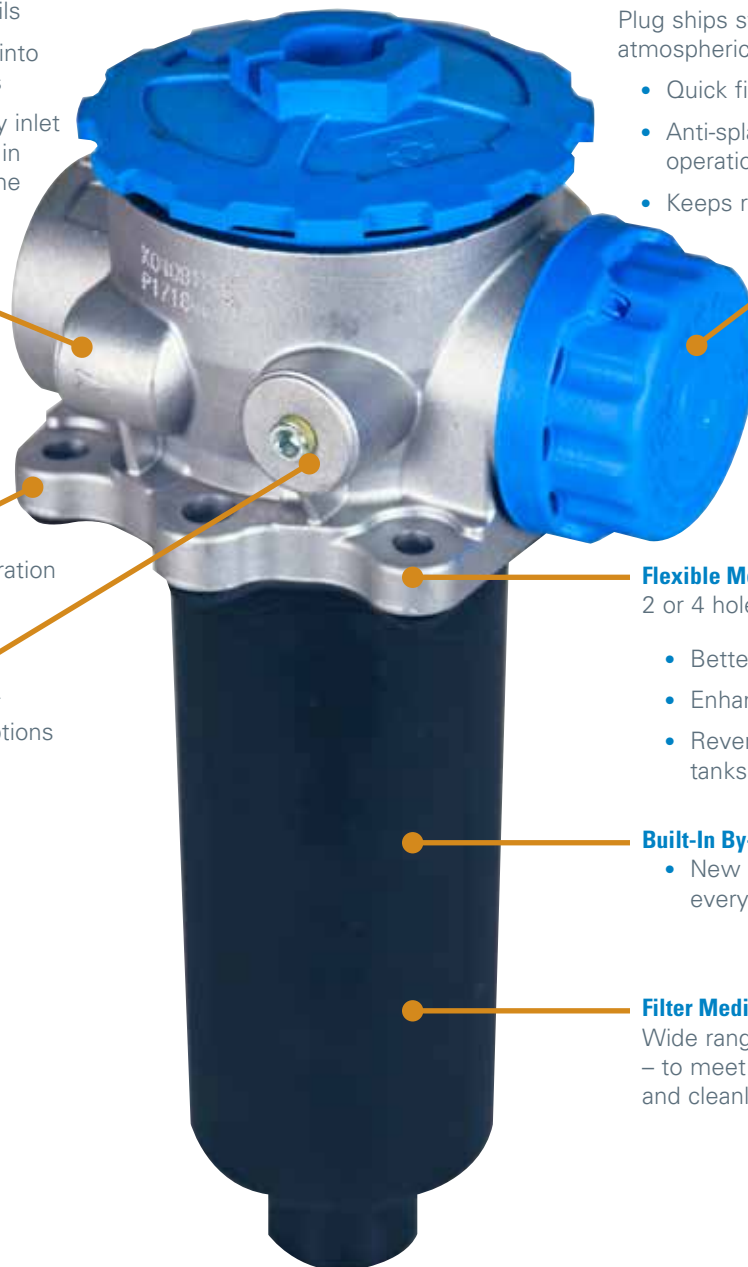

T.R.A.P.™ Breather Technology Breather ordered separately

Plug ships standard. Pressurized & atmospheric breathers available.

- Quick fit connection
- Anti-splash design allows smooth operation under tilt conditions
- Keeps reservoir free from condensation

Flexible Mounting Configurations

2 or 4 hole mounting option

- Better sealing and stability
- Enhanced stability on plastic tanks
- Reverse compatible – retrofit existing tanks with the new hole configuration

Built-In By-Pass Valve

- New by-pass valve installed with every filter replacement

Filter Media Technology

Wide range of Donaldson media offerings – to meet various performance targets and cleanliness standards



FIK

Max Flow: 170 gpm (644 lpm)



FIK Specification Illustrations

LOW FLOW ASSEMBLIES
 < 32 gpm (120 lpm)

HIGH FLOW ASSEMBLIES
 5 - 170 gpm (18 - 643 lpm)

STYLE A
 K030319



STYLE B
 K040811
 K040812
 K040813
 K041782



STYLE C, D, E
 Assembly part numbers on following page

Improved Design Feature

- 2 or 4 hole mounting options
- Built-in by-pass valve in the cartridge
- Improved seal design
- Anti-splash air flow path
- Optional mini T.R.A.P. breather

Improved Design Feature

- 2 or 4 hole mounting options
- Built-in by-pass valve in the cartridge
- Improved seal design
- Anti-splash air flow path
- Optional mini T.R.A.P. breather
- Multifunctional ports for accessories

Improved Design Feature

- Improved seal design
- Built-in by-pass valve in the cartridge

ASSEMBLY - SIDE VIEW

STYLE A

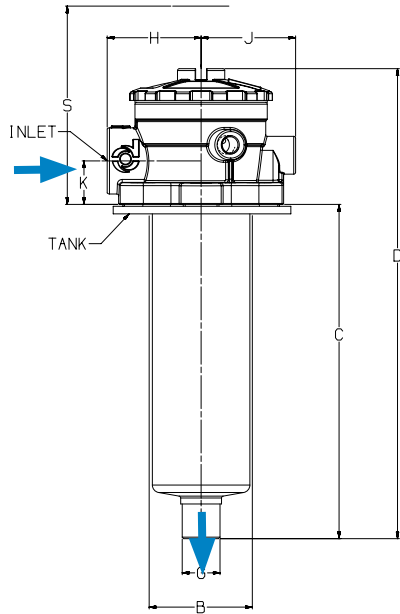

STYLE B

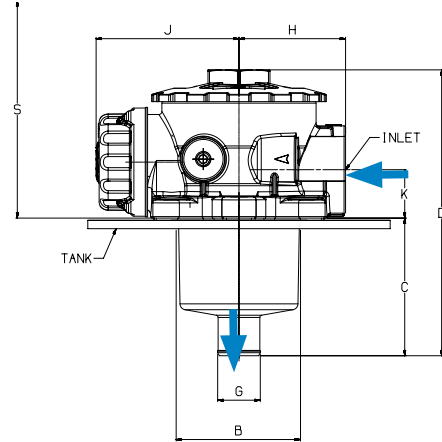

STYLE C, D, E

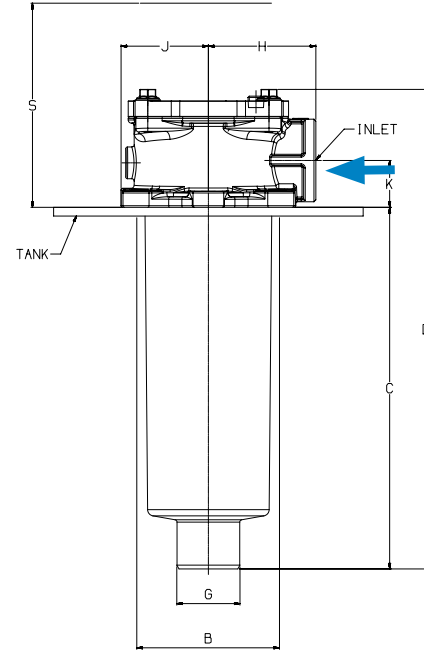

HEAD - TOP VIEW

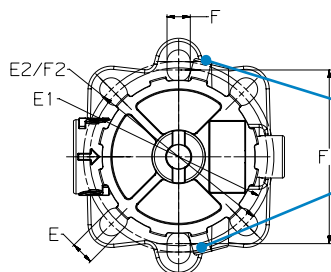

Ports for service indicator

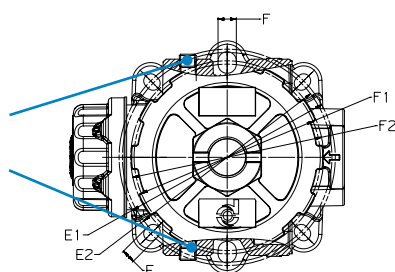

HIGH FLOW ASSEMBLIES

5 - 170 gpm (18 - 643 lpm)

<p>STYLE C K041770 K041774 K041771 K040799 K041772 K040798 K041773 K031027 (2 point mount only)</p> 	<p>STYLE D K070248 K070250 K071001 K071003 K070249 K071002</p> 	<p>STYLE E K051204 K052053</p> 
<p>Improved Design Feature</p> <ul style="list-style-type: none"> • 2 or 4 hole mounting options 	<p>Design Feature</p> <ul style="list-style-type: none"> • 4 hole mounting 	<p>Design Feature</p> <ul style="list-style-type: none"> • 3 hole mounting

HEAD - TOP VIEW

STYLE C

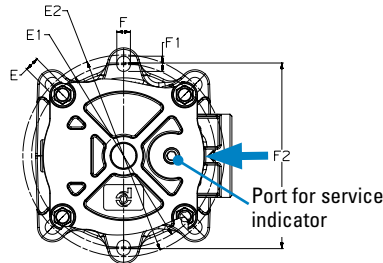

STYLE D

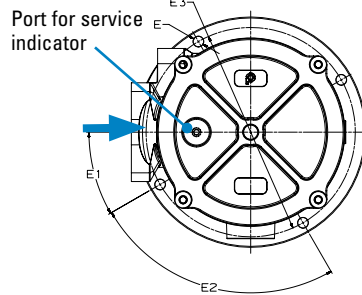

STYLE E

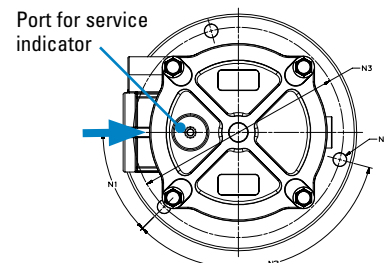

Dimensions

ASSEMBLY DIMENSIONS	ASSEMBLY PART NUMBER																							
	STYLE A		STYLE B				STYLE C						STYLE D				STYLE E							
	K030319	K040811	K040812	K040813 K041782	K031027 2 pt mount only	K041770	K041771 K041772 K041773 K040799	K040798	K070248 K071001	K070249 K071002	K070250 K071003	K051204 K052053												
mm	in	mm	in	mm	in	mm	in	mm	in	mm	in	mm	in	mm	in	mm	in	mm	in	mm	in			
C	176.8	6.96	91.0	3.58	141.0	5.55	218.0	8.58	78.0	3.07	99.0	3.90	149.0	5.87	227.7	8.96	242.0	9.53	290.0	11.42	434.0	17.09	224.0	8.82
D	248.6	9.79	189.0	7.44	239.0	9.41	316.0	12.44	132.0	5.20	173.3	6.82	223.2	8.79	301.9	11.89	348.0	13.70	395.5	15.57	539.5	21.24	313.8	12.35
S SERVICE CLEARANCE	220.0	8.66	180.0	7.09	220.0	8.66	305.0	12.01	149.0	5.87	170.0	6.69	220.0	8.66	299.0	11.77	320.0	12.60	365.0	14.37	515.0	20.28	305.0	12.01
G	20.0	0.79	27.6	1.09	27.6	1.09	39.6	1.56	25.2	0.99	27.6	1.09	27.6	1.09	39.5	1.56	50.0	1.97	63.5	2.50	63.5	2.50	40.0	1.57
B TANK OPENING	57.0	2.24	90.0	3.54	90.0	3.54	90.0	3.54	68.6	2.70	90.0	3.54	90.0	3.54	90.0	3.54	175.0	6.89	175.0	6.89	175.0	6.89	131.0	5.16
H	49.7	1.96	70.5	2.78	70.5	2.78	70.5	2.78	49.0	1.93	68.0	2.68	68.0	2.68	68.0	2.68	120.0	4.72	126.0	4.96	126.0	4.96	95.0	3.74
J	54.2	2.13	94.5	3.72	94.5	3.72	94.5	3.72	44.0	1.73	55.0	2.17	55.0	2.17	55.0	2.17	100.0	3.94	100.0	3.94	100.0	3.94	78.0	3.07
K	23.0	0.91	32.0	1.26	32.0	1.26	32.0	1.26	22.0	0.87	29.5	1.16	29.5	1.16	29.5	1.16	41.0	1.61	48.5	1.91	48.5	1.91	35.0	1.38
F 2 POINT MOUNT	11.0	0.43	11.0	0.43	11.0	0.43	11.0	0.43	Ø6.4	Ø0.25	8.5	0.33	8.5	0.33	8.5	0.33	N/A	N/A	N/A	N/A	N/A	N/A	N/A	N/A
F1	Ø82	Ø3.23	Ø112	Ø4.41	Ø112	Ø4.41	Ø112	Ø4.41	90.0	3.54	9.5	0.37	9.5	0.37	9.5	0.37	N/A	N/A	N/A	N/A	N/A	N/A	N/A	N/A
F2	Ø90	Ø3.54	Ø116	Ø4.57	Ø116	Ø4.57	Ø116	Ø4.57	N/A	N/A	115.0	4.53	115.0	4.53	115.0	4.53	N/A	N/A	N/A	N/A	N/A	N/A	N/A	N/A
N 3 POINT MOUNT	N/A	N/A	N/A	N/A	N/A	N/A	N/A	N/A	N/A	N/A	N/A	N/A	N/A	N/A	N/A	N/A	N/A	N/A	N/A	N/A	N/A	N/A	N/A	N/A
N1	N/A	N/A	N/A	N/A	N/A	N/A	N/A	N/A	N/A	N/A	N/A	N/A	N/A	N/A	N/A	N/A	N/A	N/A	N/A	N/A	N/A	N/A	N/A	45°
N2	N/A	N/A	N/A	N/A	N/A	N/A	N/A	N/A	N/A	N/A	N/A	N/A	N/A	N/A	N/A	N/A	N/A	N/A	N/A	N/A	N/A	N/A	N/A	120°
N3	N/A	N/A	N/A	N/A	N/A	N/A	N/A	N/A	N/A	N/A	N/A	N/A	N/A	N/A	N/A	N/A	N/A	N/A	N/A	N/A	N/A	N/A	N/A	Ø175
E 4 POINT MOUNT	11.0	0.43	8.5	0.33	8.5	0.33	8.5	0.33	N/A	N/A	9.0	0.35	9.0	0.35	9.0	0.35	Ø10.5	Ø0.41	Ø11	Ø0.43	Ø11	Ø0.43	N/A	N/A
E1	Ø84	Ø3.31	Ø126	Ø4.96	Ø126	Ø4.96	Ø126	Ø4.96	N/A	N/A	Ø115	Ø4.53	Ø115	Ø4.53	Ø115	Ø4.53	30°	30°	30°	30°	30°	30°	30°	N/A
E2	Ø90	Ø3.54	Ø130	Ø5.12	Ø130	Ø5.12	Ø130	Ø5.12	N/A	N/A	Ø126	Ø4.96	Ø126	Ø4.96	Ø126	Ø4.96	90°	90°	90°	90°	90°	90°	90°	N/A
E3	N/A	N/A	N/A	N/A	N/A	N/A	N/A	N/A	N/A	N/A	N/A	N/A	N/A	N/A	N/A	N/A	Ø220	Ø8.66	Ø220	Ø8.66	Ø220	Ø8.66	Ø220	N/A
WEIGHT	lbs	kg	lbs	kg	lbs	kg	lbs	kg	lbs	kg	lbs	kg	lbs	kg	lbs	kg	lbs	kg	lbs	kg	lbs	kg	lbs	kg
K	1.8	0.8	2.1	0.95	3.2	1.45	4.1	1.86	1.1	0.5	1.8	0.8	2.1	0.95	2.43	1.1	10.0	4.5	13.1	5.9	18.6	8.4	7.0	3.2



FIK Components

Assembly Choices

Port Size	Bypass Rating*	Assembly Part No.	$\beta_{x(c)} = 1000$	Filter Media ¹	Provided with Filter	Filter Diameter (in/mm)	Filter Length (in/mm)	Flow Range (@~5 psid / 34.5 kPa)
'additional filter choices on following pages to meet various performance requirements								
Low Flow Assemblies								
STYLE A								
SAE-8 O-Ring	22 psi/1.5 bar	K030319	36 μ m	Cellulose	P171839	1.69 / 43	6.38 / 162	10 gpm / 38 lpm
STYLE B								
SAE-12 O-Ring	22 psi/1.5 bar	K040811	36 μ m	Cellulose	P171527	2.76 / 70	3.23 / 82	14 gpm / 53 lpm
SAE-16 O-Ring	22 psi/1.5 bar	K040812	36 μ m	Cellulose	P171533	2.76 / 70	5.04 / 128	23 gpm / 86 lpm
SAE-20 O-Ring	22 psi/1.5 bar	K040813	36 μ m	Cellulose	P171840	2.76 / 70	8.27 / 210	32 gpm / 120 lpm
SAE-20 O-Ring	22 psi/1.5 bar	K041782	11 μ m	Synthetic	P171846	2.76 / 70	8.27 / 210	28 gpm / 106 lpm
High Flow Assemblies								
STYLE C								
1/2" NPT	22 psi/1.5 bar	K031027	36 μ m	Cellulose	P171503	2.05 / 52	2.64 / 67	5 gpm / 18 lpm
1" NPT	22 psi/1.5 bar	K041770	36 μ m	Cellulose	P171527	2.76 / 70	3.23 / 82	15 gpm / 56 lpm
3/4" NPT	22 psi/1.5 bar	K041771	36 μ m	Cellulose	P171533	2.76 / 70	5.04 / 128	18 gpm / 68 lpm
1" NPT	22 psi/1.5 bar	K041772	36 μ m	Cellulose	P171533	2.76 / 70	5.04 / 128	21 gpm / 79 lpm
SAE-12 O-Ring	22 psi/1.5 bar	K041773	36 μ m	Cellulose	P171533	2.76 / 70	5.04 / 128	18 gpm / 68 lpm
SAE-12 O-Ring	22 psi/1.5 bar	K041774	11 μ m	Synteq	P171531	2.76 / 70	5.04 / 128	13 gpm / 49 lpm
SAE-16 O-Ring	22 psi/1.5 bar	K040799	36 μ m	Cellulose	P171533	2.76 / 70	5.04 / 128	21 gpm / 79 lpm
SAE-16 O-Ring	22 psi/1.5 bar	K040798	36 μ m	Cellulose	P171840	2.76 / 70	8.22 / 209	32 gpm / 120 lpm
STYLE D								
SAE-24 O-Ring	22 psi/1.5 bar	K070248	36 μ m	Cellulose	P171557	5.51 / 140	7.49 / 203	66 gpm / 248 lpm
SAE-24 O-Ring	22 psi/1.5 bar	K071001	11 μ m	Synteq	P171555	5.51 / 140	7.49 / 203	44 gpm / 165 lpm
2" SAE 4-Bolt	22 psi/1.5 bar	K070249	36 μ m	Cellulose	P171575	5.51 / 140	9.84 / 250	106 gpm / 399 lpm
2" SAE 4-Bolt	22 psi/1.5 bar	K071002	11 μ m	Synteq	P171573	5.51 / 140	9.84 / 250	74 gpm / 278 lpm
2" SAE 4-Bolt	22 psi/1.5 bar	K070250	36 μ m	Cellulose	P171581	5.51 / 140	15.75 / 400	170 gpm / 644 lpm
2" SAE 4-Bolt	22 psi/1.5 bar	K071003	11 μ m	Synteq	P171579	5.51 / 140	15.75 / 400	120 gpm / 451 lpm
STYLE E								
SAE-20 O-Ring	22 psi/1.5 bar	K051204	36 μ m	Cellulose	P171539	3.74 / 95	7.49 / 203	47 gpm / 177 lpm
SAE-20 O-Ring	22 psi/1.5 bar	K052053	11 μ m	Synteq	P171537	3.74 / 95	7.49 / 203	32 gpm / 120 lpm





Note
 *Bypass valve is an integral part of the replacement filter.
 Service indicator port available for all assemblies.
 Filter Notes
 FIK filters utilize either glass fiber, cellulose, or wire mesh media.
 All FIK filters are potted with polyurethane adhesives.
 Synteq media designs are double wire-backed using epoxy-coated steel mesh for maximum pleat support and dirt capacity.
 Nitrile seals are standard on all FIK filters.



T.R.A.P.™ Breather Choices

For Redesigned Style A and B Assemblies with 4 Hole Mounting Configurations Only

Note: T.R.A.P. breathers are not compatible on older style assemblies with 2 hole mounting configuration

Part No.	Description	Efficiency	Fits Assembly Models:
STYLE A			
 P567392	Mini T.R.A.P.	3 µm @ 97%	K030319
STYLE B			
 P766528	Black Standard plug (no air exchange)	N/A	K040811, K040812, K040813, K041782
 P766530	Blue Atmospheric pressure	10 µm @ 98%	K040811, K040812, K040813, K041782
 P766538	Red 7.3 psi (½ bar) pressurized	10 µm @ 98%	K040811, K040812, K040813, K041782



Standard Breather Choices

Replacement Breathers for Older Style A and B Assemblies with 2 Hole Mounting Configuration Only

Part No.	Efficiency	Fits Assembly Models:
STYLE A		
P173330	10 µm	K030319
STYLE B		
P172434	10 µm	K040811, K040812, K040813



Service Indicators

Pressure Gauges
P171956
G 1/8"
(center back)



P171953
G 1/8"
(bottom mount)

-14.5 to 72 psi
-1 to +5 bar

DC Electrical Indicator
P171966
17 psi / 1.2 bar
(48V AC/DC)



Visual Indicator
P171958
17 psi / 1.2 bar





FIK Components

Filter Choices - Low Flow Assemblies

Media Type	$\beta_{x(c)} = 2$	$\beta_{x(c)} = 1000$	Length		Part No.
	Rating based on ISO 16889		in	mm	
STYLE A					
K030319					
Synteq Synthetic		6 μ m	6.38	162	P569273
		11 μ m	6.38	162	P171845
		23 μ m	6.38	162	P171842
Cellulose	7 μ m		6.38	162	P171839
	27 μ m		6.38	162	P171836
Wire Mesh	60 μ m		6.38	162	P171833
	90 μ m		6.38	162	P171830

Filter Choices - Low Flow Assemblies

Media Type	$\beta_{x(c)} = 2$	$\beta_{x(c)} = 1000$	Length		Part No.
	Rating based on ISO 16889		in	mm	
STYLE B					
K040811					
Synteq Synthetic		11 μ m	3.23	82	P171525
		23 μ m	3.23	82	P171526
Cellulose	7 μ m		3.23	82	P171527
	27 μ m		3.23	82	P171528
Wire Mesh	60 μ m		3.23	82	P171529
	90 μ m		3.23	82	P171524
K040812					
Synteq Synthetic		6 μ m	5.04	128	P569275
		11 μ m	5.04	128	P171531
		23 μ m	5.04	128	P171532
Cellulose	7 μ m		5.04	128	P171533
	27 μ m		5.04	128	P171534
Wire Mesh	60 μ m		5.04	128	P171535
	90 μ m		5.04	128	P171530
K040813					
Synteq Synthetic		6 μ m	8.27	210	P569276
		11 μ m	8.27	210	P171846
		23 μ m	8.27	210	P171843
Cellulose	7 μ m		8.27	210	P171840
	27 μ m		8.27	210	P171837
Wire Mesh	60 μ m		8.27	210	P171834
K041782					
Synteq Synthetic		6 μ m	8.27	210	P569276
		11 μ m	8.27	210	P171846
		23 μ m	8.27	210	P171843
Cellulose	7 μ m		8.27	210	P171840
	27 μ m		8.27	210	P171837
Wire Mesh	60 μ m		8.27	210	P171834

Filter Choices - High Flow Assemblies

Media Type	$\beta_{x(c)} = 2$	$\beta_{x(c)} = 1000$	Length		Part No.
	Rating based on ISO 16889		in	mm	
STYLE C					
K031027					
Synteq Synthetic		6 μ m	2.64	67	P569277
		11 μ m	2.64	67	P171501
		23 μ m	2.64	67	P171502
Cellulose	7 μ m		2.64	67	P171503
	27 μ m		2.64	67	P171504
Wire Mesh	60 μ m		2.64	67	P171505
	90 μ m		2.64	67	P171500
K041770					
Synteq Synthetic		11 μ m	3.23	82	P171525
		23 μ m	3.23	82	P171526
Cellulose	7 μ m		3.23	82	P171527
	27 μ m		3.23	82	P171528
Wire Mesh	60 μ m		3.23	82	P171529
	90 μ m		3.23	82	P171524
K041771, K041772, K041773, K041774, K040799					
Synteq Synthetic		6 μ m	5.04	128	P569275
		11 μ m	5.04	128	P171531
		23 μ m	5.04	128	P171532
Cellulose	7 μ m		5.04	128	P171533
	27 μ m		5.04	128	P171534
Wire Mesh	60 μ m		5.04	128	P171535
	90 μ m		5.04	128	P171530
K040798					
Synteq Synthetic		6 μ m	8.22	209	P569276
		11 μ m	8.22	209	P171846
		23 μ m	8.22	209	P171843
Cellulose	7 μ m		8.22	209	P171840
	27 μ m		8.22	209	P171837
Wire Mesh	60 μ m		8.22	209	P171834

Filter Choices - High Flow Assemblies

Media Type	$\beta_{x(c)} = 2$	$\beta_{x(c)} = 1000$	Length		Part No.
	Rating based on ISO 16889		in	mm	
STYLE D					
K070248, K071001					
Synteq Synthetic		6 μ m	7.49	203	P569279
		11 μ m	7.49	203	P171555
		23 μ m	7.49	203	P171556
Cellulose	7 μ m		7.49	203	P171557
	27 μ m		7.49	203	P171558
Wire Mesh	60 μ m		7.49	203	P171559
K070249, K071002					
Synteq Synthetic		6 μ m	9.84	250	P569280
		11 μ m	9.84	250	P171573
		23 μ m	9.84	250	P171574
Cellulose	7 μ m		9.84	250	P171575
	27 μ m		9.84	250	P171576
Wire Mesh	90 μ m		9.84	250	P171572
K070250, K071003					
Synteq Synthetic		6 μ m	15.75	400	P176749
		11 μ m	15.75	400	P171579
		23 μ m	15.75	400	P171580
Cellulose	7 μ m		15.75	400	P171581
	27 μ m		15.75	400	P171582
Wire Mesh	60 μ m		15.75	400	P171583
	90 μ m		15.75	400	P171578
STYLE E					
K051204, K052053					
Synteq Synthetic		6 μ m	7.49	203	P569278
		11 μ m	7.49	203	P171537
		23 μ m	7.49	203	P171538
Cellulose	7 μ m		7.49	203	P171539
	27 μ m		7.49	203	P171540
Wire Mesh	60 μ m		7.49	203	P171541
	90 μ m		7.49	203	P171536



FIK

Max Flow: 170 gpm (644 lpm)



Performance Data

STYLE A

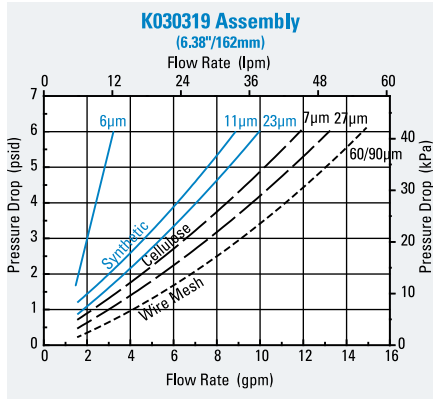

NOTE:
Please note that the line styles used represent different media types

- Synthetic
- - - Cellulose
- · - · Wire Mesh

STYLE B

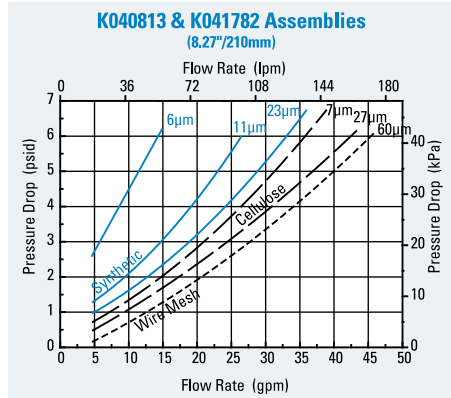
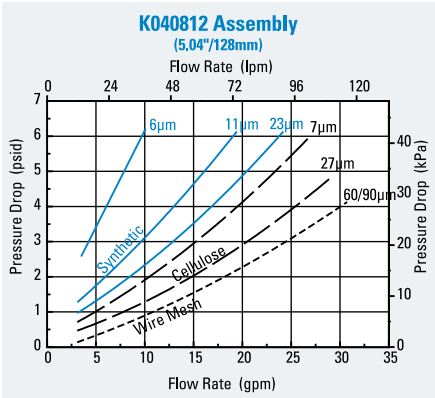
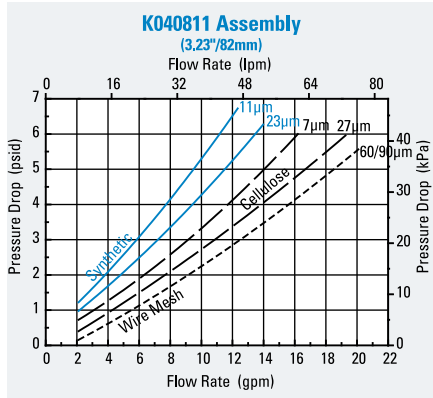

STYLE C

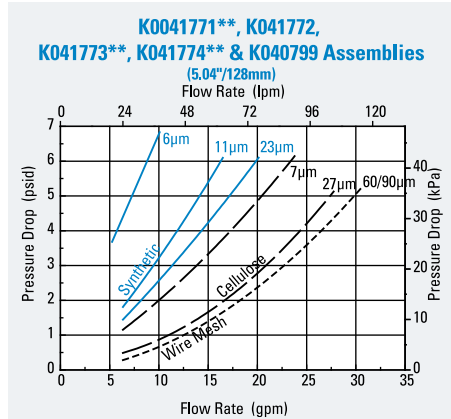
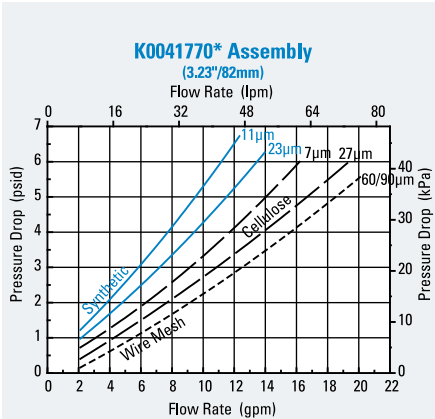
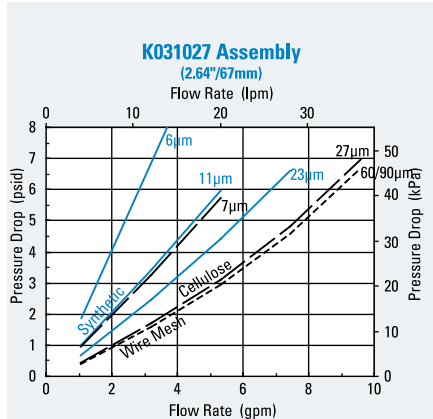

*Subtract ½ psi
**Add ½ psi

Performance Data

STYLE C, continued

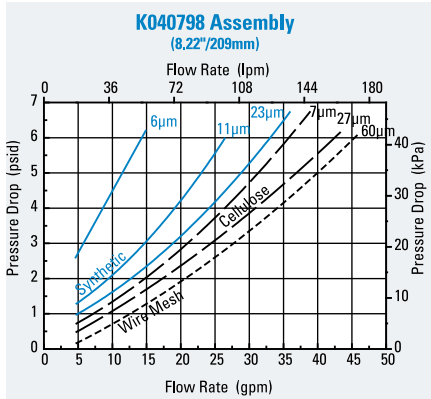

STYLE D

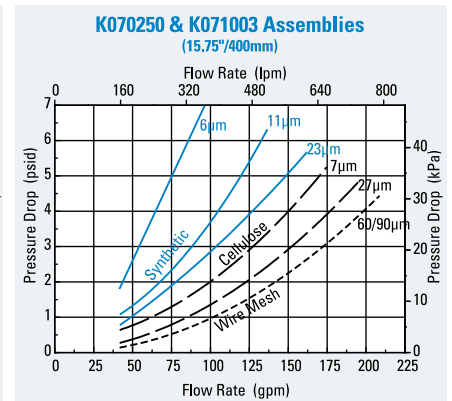
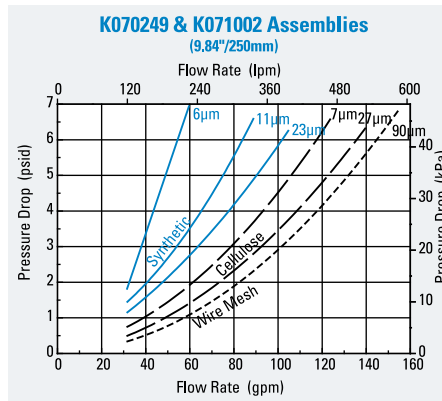
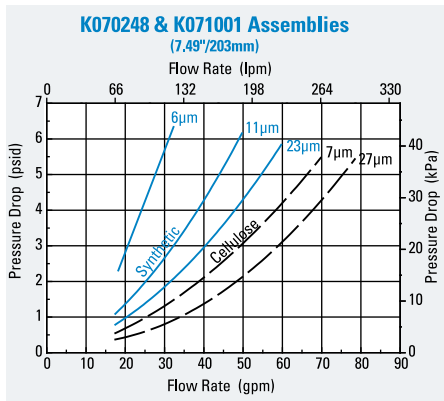

STYLE E

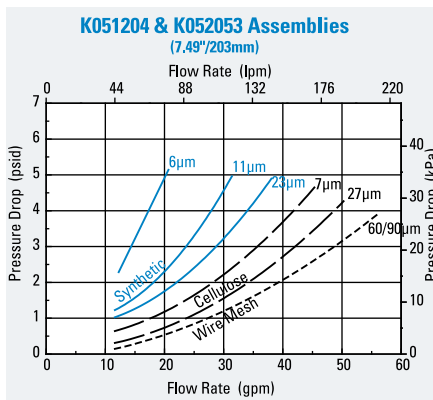



SRK Combo

Max Flow: 79 gpm (300 lpm)



SRK Suction/Return Combination In-Tank Filters

Working Pressures to:

145 psi / 1000 kPa / 10.0 bar

Rated Static Burst to:

217 psi / 1497 kPa / 15.0 bar

Flow Range To:

79 gpm / 300 lpm

Applications

- Hydrostatic Transmissions
- Mobile Equipment

Features

The SRK tank-mounted suction and return filter is a popular choice for hydrostatic transmissions. The filtered flow is maintained at a slight backpressure to provide clean, pressurized oil, mainly for charge pumps in hydrostatic transmission systems. The pressurized flow is designed to reduce cavitation risks. This patented design uses an integrated main flow and bypass flow filter, which is capable of delivering filtered and pressurized oil, even in bypass situations. Emergency suction flow is also filtered. The SRK operates in a standard flow (outside to inside) configuration. SAE O-Ring ports are standard to meet popular application requirements.

- 4-point mounting
- Head material: aluminum
- Housing material: steel
- Cover material: glass-filled nylon
- Nitrile seals standard
- Main filters include integrated bypass filters



Beta Rating (per ISO 16889)

- Performance to $\beta_{13(c)}=1000$

Porting Size Options

- Inlet: SAE-16, SAE-20 O-Ring
- Outlet: SAE-16 O-Ring

Replacement Filter Lengths

- 18.6" / 472mm

Standard Bypass Ratings

- 36 psi / 250 kPa / 2.5 bar

Standard Backpressure Ratings

- 7.3 psi / 50 kPa / 0.5 bar

Assembly Weight

- 10.8 lbs / 4.9 kg

Operating Temperatures

- -22°F to 212°F / -30°C to 100°C

Filter Collapse Ratings

- 145 psid / 1000 kPa / 10 bar

Return Flow Rate

- 79 gpm (300 lpm)

Emergency Suction Flow Rate

- 27 gpm (100 lpm)

SRK Filter Assemblies

Part No.	Inlet Port Connections	Outlet Port Connections	Bypass Valve	Emergency Suction	Comments
K041634	SAE-20 & SAE-16	(2) - SAE-16	36 psi (2.5 bar)	125 µm Wire Mesh	Indicator not included

Filter Choices

Media Type	$\beta_{x(c)} = 1000$	Length		Part No.	Bypass	Comments
	Rating based on ISO 16889	in	mm			
Synteq Synthetic	13 µm	18.6	472	P765457	125 µm Wire	For Combo 300 Assemblies

Standard collapse designs are double wire-backed using epoxy-coated steel mesh for maximum pleat support and dirt capacity. All SRK filters are standard flow (outside to inside). Nitrile seals are standard on all SRK filters.

Suction Filter Choices

Media Type	$\beta_{x(c)} = 2$	Length		Part No.
	Rating based on ISO 16889	in	mm	
Wire Mesh	125 µm	1.98	50.2	P764183

Indicator Options

Part No.	Set Point	Style	Connection
P764612	36 psi (2.5 bar)	Visual	G1/8"

ASSEMBLY - SIDE VIEW

All dimensions are shown in millimeters [inches].

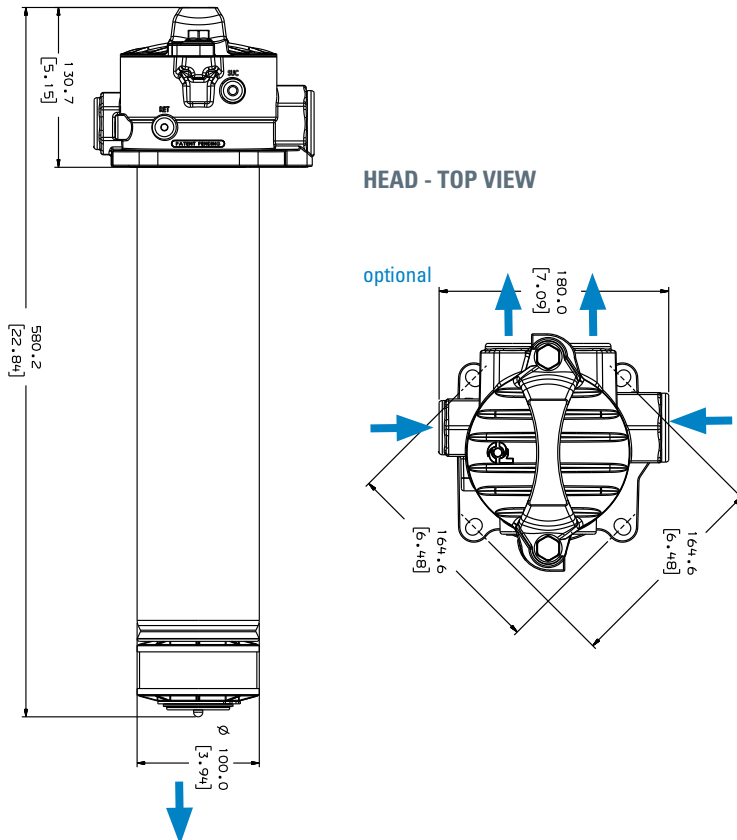

shop.donaldson.com

Performance Data

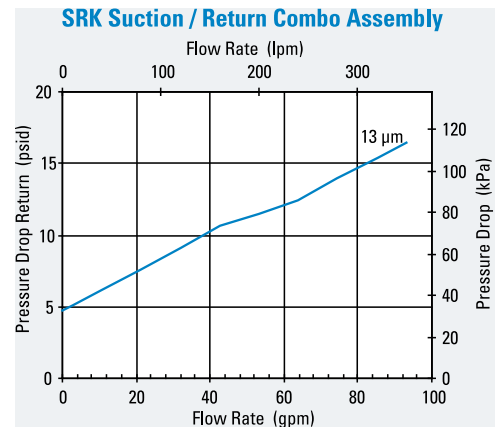

Flow Schematic

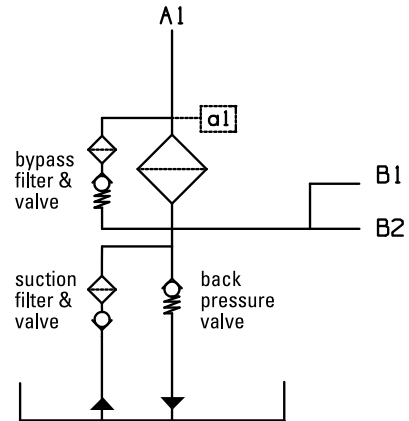



HRK10

Max Flow: 300 gpm (1135 lpm)



HRK10 In-Line Cartridge Filters

Working Pressures to:

150 psi / 1035 kPa / 10.3 bar

Rated Static Burst to:

500 psi / 3450 kPa / 34.5 bar

Flow Range To:

300 gpm / 1135 lpm

Applications

- Fluid Conditioning Systems
- In-Plant Systems
- Lube Oil Systems
- Side Loop Systems

Features

The HRK10 high flow filter combines the best features of its predecessor, the HEK11: ANSI inlet port options, top cover filter servicing for ease of maintenance, and a selection of service indicators. The HRK10 all-steel housing design provides a strong, durable, and dependable unit. It offers standard features like deep pleat filters for higher dirt holding capacity and standard Donaldson DT 4-layer media filter construction. This technology, combined with many other standard features, is ideal for today's applications in pulp and paper, power generation and steel mill applications. A port for an electrical indicator is incorporated into the differential indicator block.

- Robust "Twist & Lift" cover for simplified servicing
- Multiple bypass valve design assures proper operation
- Wide variety of bypass valve ratings
- Reverse flow (inside to outside) filters for positive contamination containment
- Fluorocarbon seals standard
- Housing & cover material: steel
- Drain plug in bottom
- Bleed valve in cover
- Fill plug in cover



Beta Rating (per ISO 16889)

- Performance to $\beta_{<4(c)}=1000$

Porting Size Options

- 4" ANSI Flange, 8-bolt 150#

Replacement Filter Lengths

- 21.99" / 559mm

Standard Bypass Ratings

- 5 psi / 34.5 kPa / 0.34 bar
- 25 psi / 172 kPa / 1.7 bar
- 50 psi / 345 kPa / 3.4 bar
- No Bypass

Assembly Weight

- 140 lbs / 64 kg

Operating Temperatures

- -20°F to 250°F (-29° to 121°C)

Filter Collapse Ratings

- 100 psid / 689 kPa / 6.9 bar



HRK10 Specification Illustrations

ASSEMBLY - SIDE VIEW

All dimensions are shown in inches [millimeters].

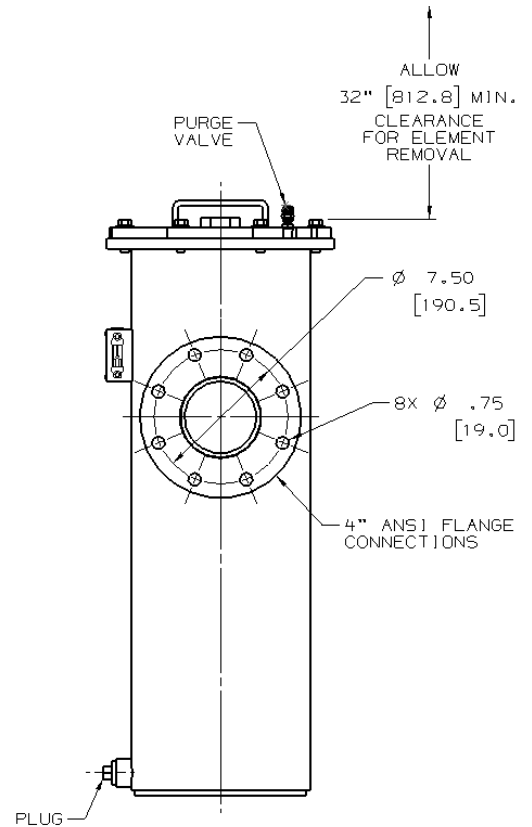
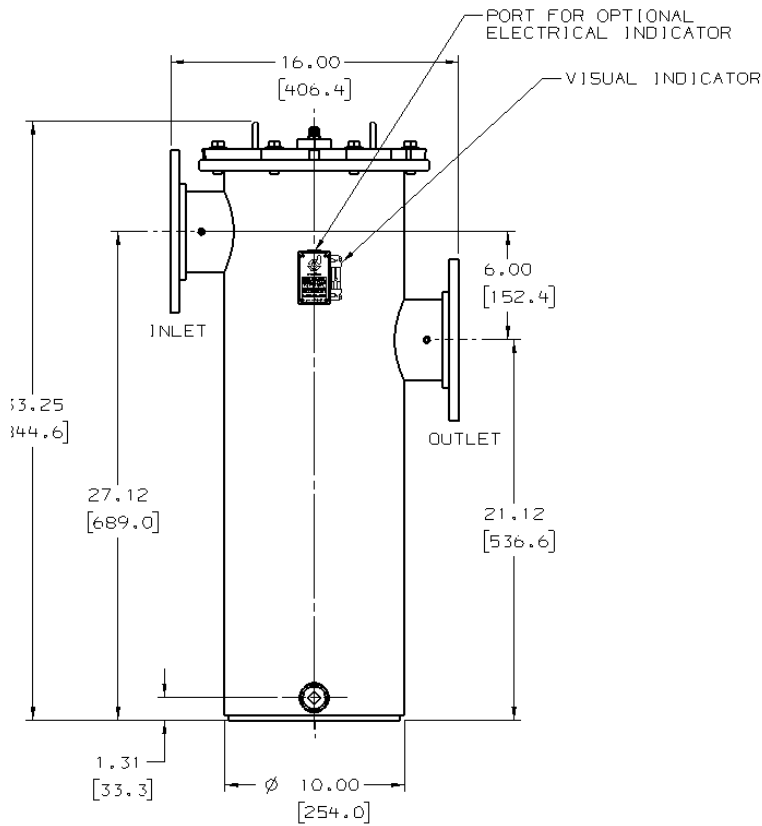

HEAD - TOP VIEW

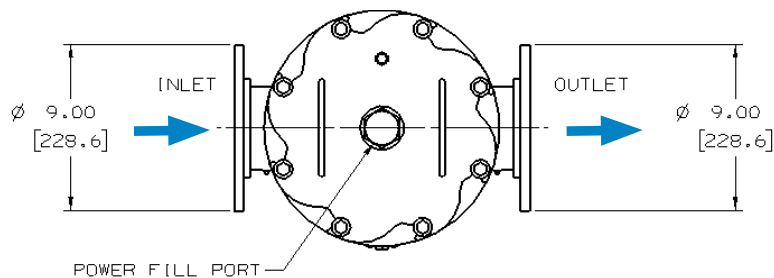



HRK10 Components

Filter Choices

Media Type	$\beta_{x(c)} = 2$	$\beta_{x(c)} = 1000$	Length		Part No.	Comments
	Rating based on ISO 16889		in	mm		
Synteq Synthetic		<4 μm	21.99	559	P566187	
		5 μm	21.99	559	P566188*	
		8 μm	21.99	559	P566189	
		12 μm	21.99	559	P566190	
		23 μm	21.99	559	P566191	
Water Absorbing	10 μm		21.99	559	P569531	Absorbs approximately 60 oz/1800 ml water @ 25 psid/1.72 bar
Wire Mesh	150 μm		21.99	559	P566192	

1000 filters utilize glass fiber media with an epoxy-based resin system for the ultimate in chemical compatibility. All Donaldson HRK10 filters are potted with epoxy-based adhesives. All HRK10 filters are reserve flow (inside to outside), keeping contaminants contained during servicing. Fluorocarbon seals are standard on all HRK10 filters.

Housing Choices

Note: Filters Ordered Separately.

Part No.	Port Connections	Bypass Valve	Indicator Options
K100001	4" ANSI Flange	No bypass	Visual standard, electrical optional
K100002	4" ANSI Flange	5 psi (0.34 bar) bypass	Visual standard, electrical optional
K100003	4" ANSI Flange	25 psi (1.7 bar) bypass	Visual standard, electrical optional
K100004	4" ANSI Flange	50 psi (3.4 bar) bypass	Visual standard, electrical optional

Electrical Indicator Options

Part No.	Set Point	Bypass Valve
P173944	20 psi (1.4 bar)	AC/DC, 3-wire
P174396	40 psi (2.8 bar)	AC/DC, 3-wire



Performance Data

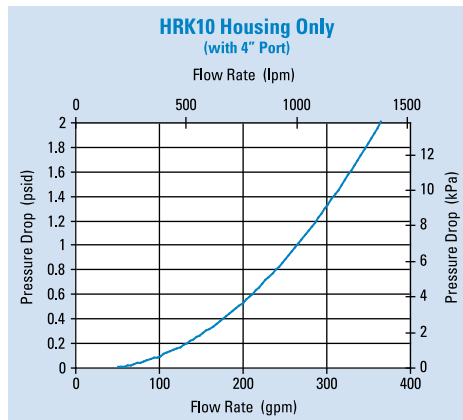
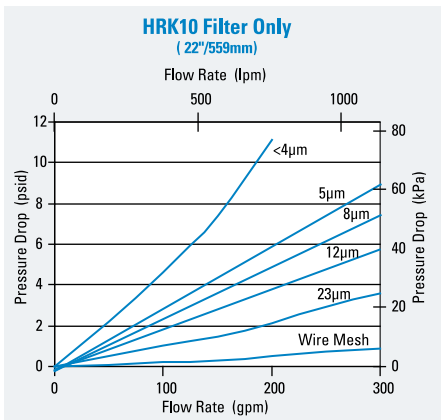

HRK10 Service Parts

SERVICE PARTS NOTE:

Some service parts may not be stocked. Please contact your Donaldson sales representative for lead time details.

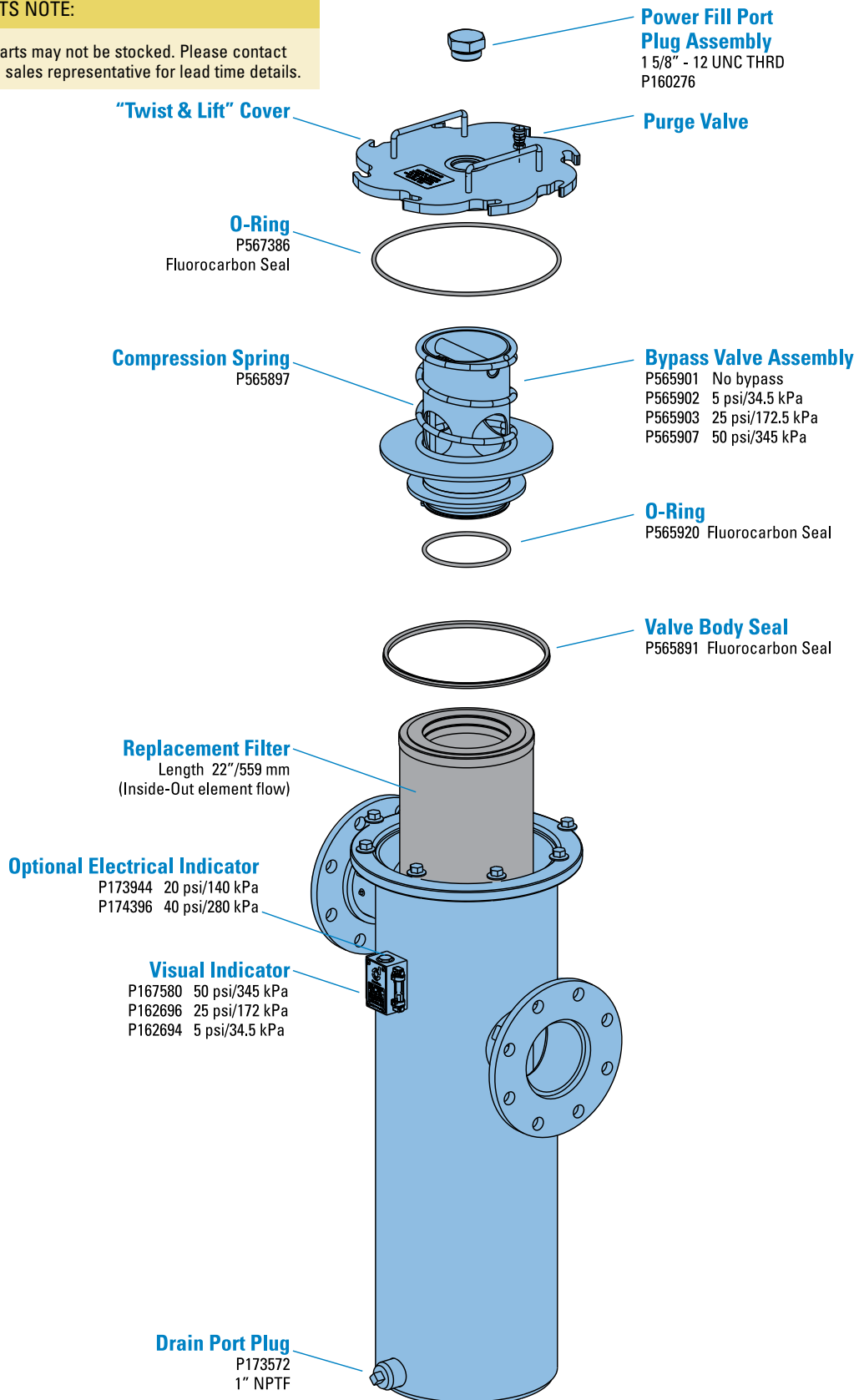

Easy.



Easier.



NOW YOU CAN SHOP FOR DONALDSON REPLACEMENT FILTERS ONLINE.

Visit shop.donaldson.com on your computer, phone or tablet to find all your top-quality aftermarket filters including fuel, lube, coolant and air intake filters for diesel engines, hydraulic and bulk tank filtration—plus exhaust system components. Distributors can now order directly with a secure login that provides access to all your account information—including past orders—so you can simply re-order with a click.

Shop.donaldson.com makes ordering replacement filters easier than easy so you can keep your business moving.

Shop for filters the easier way at
shop.donaldson.com



Medium Pressure Filters

Medium pressure filters can be used in applications up to 2000 psi (13790 kPa). Donaldson offers both spin-on and in-line cartridge-style filters.

Donaldson Duramax® filters are the highest rated medium pressure spin-on filters available. Duramax filters are proven, reliable, long-lived and easy to install.



Section Index

Max Operating Pressure < 2000 psi (138 bar)

Models arranged from low to maximum flow rates

Spin-on Filters

HMK03.....	62
HMK04.....	66
HNK04	74
HMK05.....	70
HNK05	74
HMK24.....	66
HMK25.....	70

In-line Cartridge Filters

FLK90	79
FLK110	82
FLK125	85
DPK350.....	88
HDK06.....	92
W041.....	96
HFK08	100



HMK03

Max Flow: 25 gpm (95 lpm)



HMK03 DURAMAX® Spin-On Filters

Working Pressures to:

1000 psi / 6895 kPa / 69 bar

Rated Static Burst to:

2000 psi / 13,790 kPa / 138 bar

Flow Range To:

25 gpm / 95 lpm

Features

HMK03 Series Duramax® spin-on filters offer twice the capacity of competitive filters, yet they are physically smaller than traditional housing/cartridge filter assemblies. It features a die cast aluminum head and a unique radial seal O-Ring gasket design that eliminates leakage.

Take advantage of Donaldson's mix and match system of in-stock heads, housings and media choices – so you can get exactly what you need. A full range of media options are available, using Donaldson's exclusive Synteq™ synthetic media designed especially for liquid filtration. You can also select the exact indicator types and bypass options to suit your application.

Beta Rating

- Performance to $\beta_{0.1} = 1000$

Porting Size Options

- SAE-12 O-Ring

Replacement Filter Lengths

- 5.5" / 140mm
- 9.5" / 242mm

Standard Bypass Ratings

- 50 psi / 345 kPa / 3.5 bar
- No Bypass

Applications

- Hydrostatic Charge Pumps
- Hydrostatic Transmission
- Pilot Control Circuits
- Refrigeration Compressor Circuits



Assembly Weight

- Short: 3.3 lbs / 1.5 kg
- Long: 4.2 lbs / 1.9 kg

Operating Temperatures

- -20°F to 250°F / -29°C to 121°C

Filter Collapse Ratings

- 290 psid / 20 bar

Housing Fatigue Strength Ratings*

- 100,000 Cycles: 0-1000 psi / 0-6895 kPa / 68 bar
- 300,000 Cycles: 0-800 psi / 0-5516 kPa / 55 bar
- 1,000,000 Cycles: 0-700 psi / 0-4826 kPa / 48 bar

HMK03 Specification Illustrations

ASSEMBLY - SIDE VIEW

All dimensions are shown in inches [millimeters].

Long Assembly

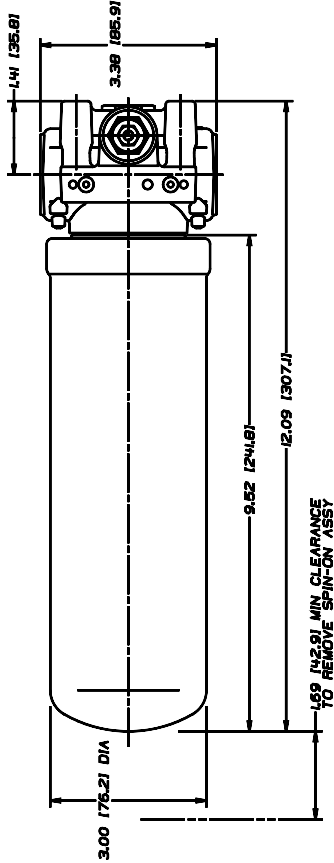

Short Assembly

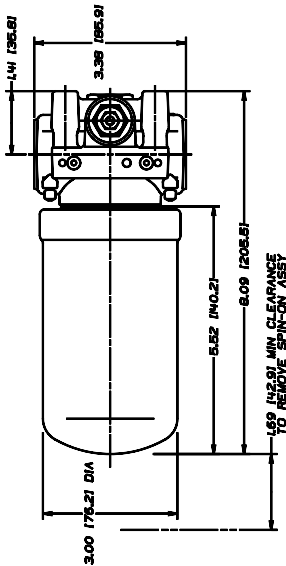

HEAD - TOP VIEW WITH INDICATORS

Head with DC Electrical Indicator

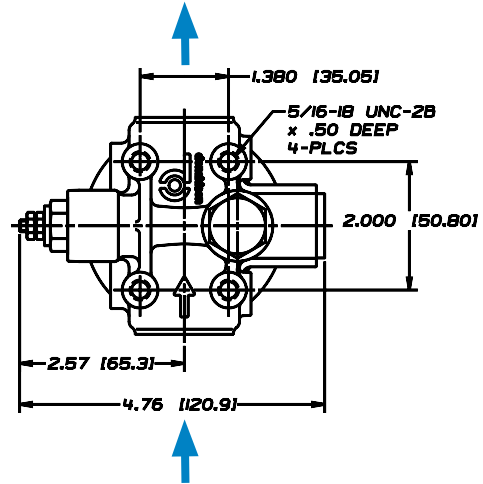

Head with AC/DC Electrical Indicator

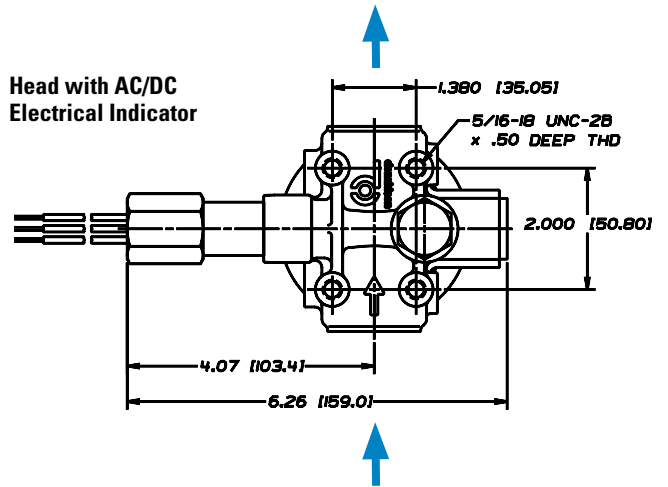

Head with Visual Indicator

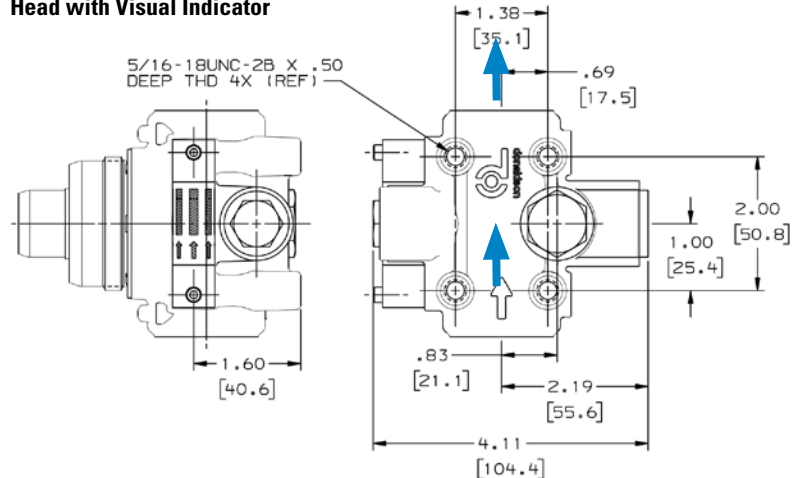



HMK03

Max Flow: 25 gpm (95 lpm)



HMK03 Components

Filter Choices

Media Type	$\beta_{x(c)} = 1000$	Length		Part No.	Comments
	Rating based on ISO 16889	in	mm		
Synteq Synthetic	6 μm	5.5	140	P170308	Nitrile
	6 μm	9.5	242	P170309	Nitrile
	11 μm	5.5	140	P170310	Nitrile
	11 μm	9.5	242	P170311	Nitrile
	23 μm	5.5	140	P170312	Nitrile
	23 μm	9.5	242	P170313	Nitrile

Filter Notes

- Synteq™ filter media is compatible with petroleum based fluids, most phosphate esters, water oil emulsions, and HWCF (high water content fluids)
- All models have 2"-12 threads



HMK03 Head

Port Size	Bypass Rating	Indicator	Head Part No.
3/4" SAE-12 O-Ring	No Bypass	None*	P170327
	50 psi / 345 kPa	None*	P170773
	50 psi / 345 kPa	Visual*	P179460

*Head is machined to accept optional electrical indicators. See Indicator list at right for the available choices.

Oil Service Indicator Choices

Use with Bypass Valve Pressure of:	Part No.	Style ²	Description ¹
25 psi / 172.5 kPa	P171143	B	Electric 2-wire DC
	P173944	C	Electric 3-wire AC/DC
	P165965	D	Visual
	P575334	H	Visual, pop up
50 psi / 345 kPa	P574719	A	Electric Single post DC
	P574968	B	Electric 2-wire DC
	P174396	C	Electric 3-wire AC/DC
	P575335	H	Visual, pop up
	P574967	E	DC 2-wire.

¹ All electric models have a maximum operating temperature of 250°F/121°C.

² See illustration of indicator styles on next page and complete details for all parts in the service indicators portion of the accessories section.

HMK03 Service Parts

Service Indicator Styles
(See table on opposite page)

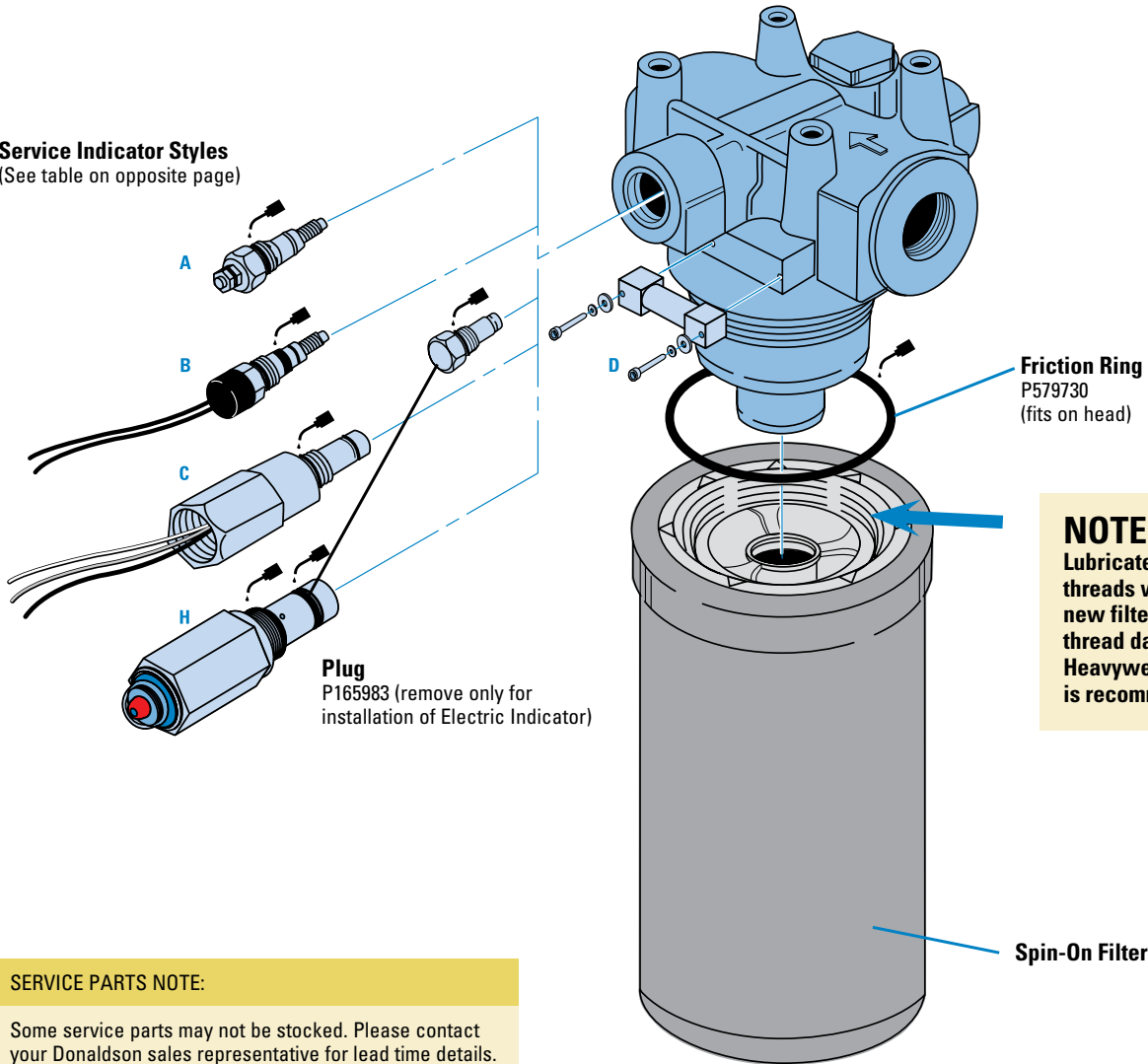

SERVICE PARTS NOTE:

Some service parts may not be stocked. Please contact your Donaldson sales representative for lead time details.

Performance Data

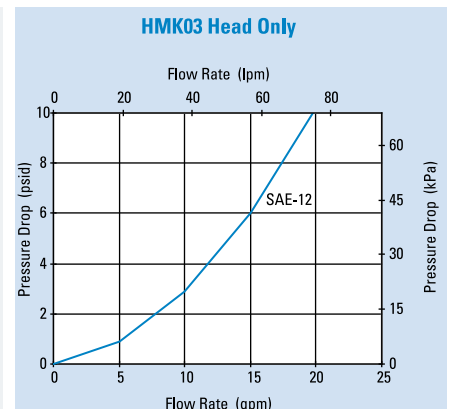
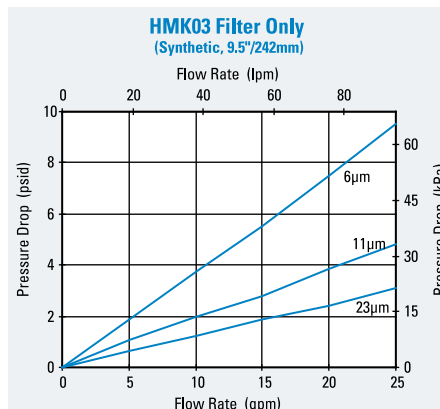
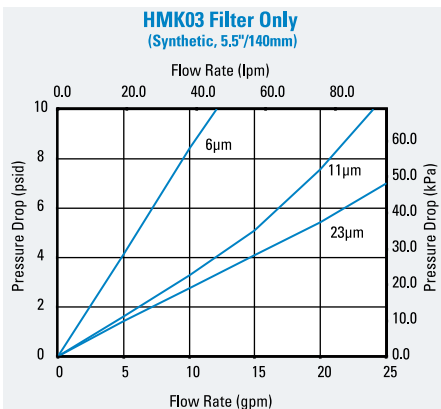



HMK04/24

Max Flow: 35 gpm (133 lpm) / 60 gpm (227 lpm)



HMK04/24 DURAMAX® Spin-On Filters

Working Pressures to:

500 psi / 3450 kPa / 35 bar

Rated Static Burst to:

1000 psi / 6895 kPa / 69 bar

Flow Range To:

HMK04: 35 gpm / 133 lpm

HMK24: 60 gpm / 227 lpm

Applications

- Case Drains
- Cooling Circuits
- Fluid Conditioning Systems
- Fuel Transfer
- Hydrostatic Charge Pumps
- Lube Oil Systems
- Power Transmissions
- Return Lines
- Side Loop Systems

Features

HMK04 (single) and HMK24 (double) Duramax® spin-on filters feature a die-cast aluminum head, heavy-duty steel body, and die-cast aluminum top plate for added strength. A special head-to-canister O-Ring seal prevents leakage. Nitrile seals are standard; fluorocarbon seals are available on some models.

Both models use the same replacement filters and feature identical pressure ratings, but the HMK24 handles greater flow capacity. There's no need to inventory two different replacement filters. A full range of media options are available, using Donaldson's exclusive Synteq™ synthetic media. Choose the indicator types and bypass options to suit your application.



Parallel Flow

Beta Rating

- Performance to $\beta_{<4(c)}=1000$

Porting Size Options

- HMK04 ¾", 1" NPT
- HMK04 SAE-12, SAE-16 O-Ring
- HMK24 SAE-20, O-Ring
- HMK24 1¼" SAE 4-Bolt Flange Code 61

Replacement Filter Lengths

- 5.97" / 152mm
- 9.4" / 240mm

Standard Bypass Ratings

- 25 psi / 173 kPa / 1.73 bar
- 50 psi / 345 kPa / 3.5 bar
- No Bypass

Assembly Weight

- HMK04 with short filter: 3.9 lbs / 1.8 kg
- HMK04 with long filter: 4.8 lbs / 2.2 kg
- HMK24: with short filter: 7.8 lbs / 3.5 kg
- HMK24: with long filter: 9.6 lbs / 4.4 kg

Operating Temperatures

- -20°F to 250°F / -29°C to 121°C (synthetic)
- -20°F to 225°F / -29°C to 107°C (cellulose)

Filter Collapse Ratings

- 150 psid / 10 bar
- 300 psid / 20 bar also available

Housing Fatigue Strength Ratings*

- 100,000 Cycles:
0-500 psi / 0-3450 kPa / 34.5 bar
- 300,000 Cycles:
0-400 psi / 0-2758 kPa / 27.6 bar
- 1,000,000 Cycles:
0-350 psi / 0-2415 kPa / 24 bar

HMK04/24 Specification Illustrations

ASSEMBLY - SIDE VIEW

All dimensions are shown in inches [millimeters].

Long Assembly

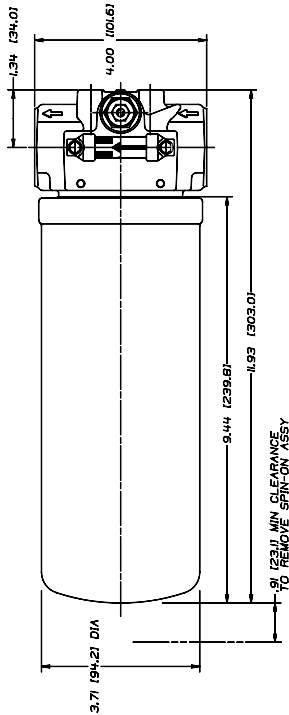

Short Assembly

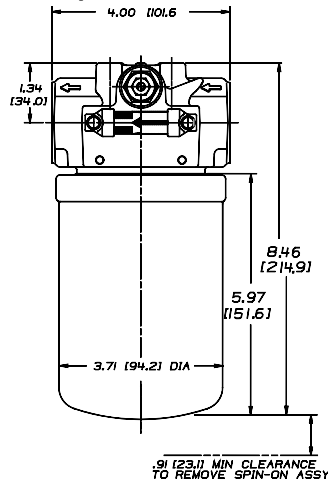

HEAD - TOP & SIDE VIEWS

HMK04 Head Top View with DC Electrical Indicator

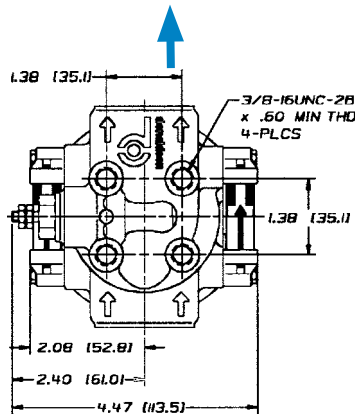

HMK04 Head Top View with AC/DC Electrical Indicator

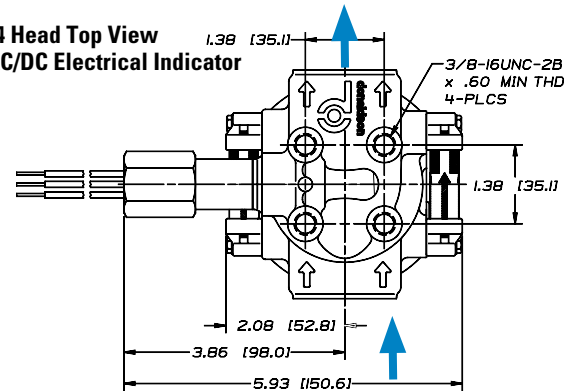

HMK24 Head Side View

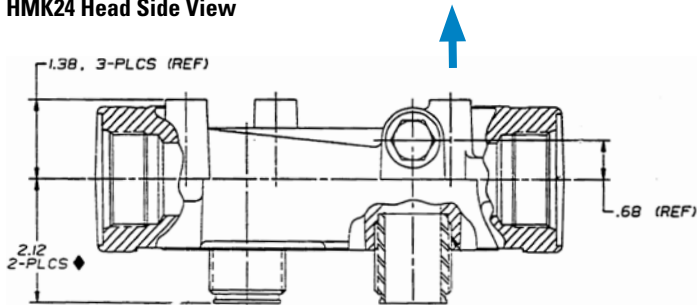

HMK24 Head Top View

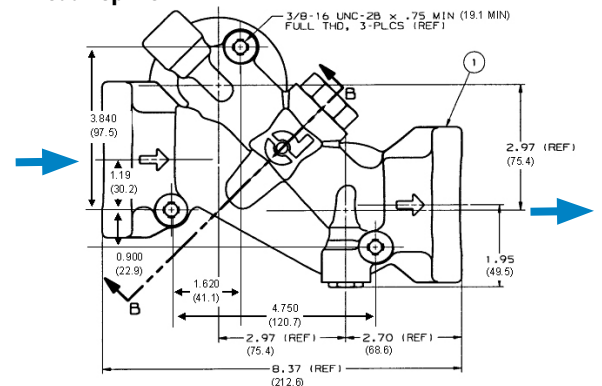



HMK04/24

Max Flow: 35 gpm (133 lpm) / 60 gpm (227 lpm)



HMK04/24 Components

Filter Choices

Media Type	$\alpha_{x(e)} = 1000$	$\beta_{x(e)} = 2$	$\beta_{x(e)} = 1000$	Length		Part No.	Comments
	Rating based on ISO 23369	Rating based on ISO 16889		in	mm		
Synteq Synthetic			<4 μm	9.4	240	P165185	'Fluorocarbon O-Ring. Compatible with water glycol
			6 μm	5.97	152	P165354	
			6 μm	9.4	240	P165332	
Alpha-Web	10 μm			5.97	152	DBH3542	
Synteq Synthetic			11 μm	5.97	152	P163542	500 psi collapse
			11 μm	5.97	152	P164375	
			11 μm	9.4	240	P164378	
			13 μm	9.4	240	P164056	'Fluorocarbon O-Ring. Compatible with water glycol
			14 μm	9.4	240	P177047	
			22 μm	9.4	240	P164059	'Fluorocarbon O-Ring. Compatible with water glycol
			23 μm	9.4	240	P163567	500 psi collapse
			23 μm	5.97	152	P164381	
			23 μm	9.4	240	P164384	
			50 μm	5.97	152	P165335	
		50 μm	9.4	240	P165338		
Water Absorbing		10 μm		9.4	240	P560584	
Wire Mesh		150 μm		9.4	240	P573301	



NOTE:
Lubricate filter-to-head threads when installing new filter to prevent thread damage. Heavyweight gear lube is recommended.

Filter Notes

- Refer to table in the Technical Reference Guide for fluid compatibility with our filter media.
- Standard filter collapse rating is 150 psi, except as noted.
- Thread size is 1 3/8"-12 UNF-2B
- Filters with seals made of nitrile are appropriate for most applications involving petroleum oil. Filters with seals made of fluorocarbon are required when using diester, phosphate ester fluids, water glycol, water/oil emulsions and HWCF (high water content fluids) over 150°F. Donaldson offers both types.

Head Choices for HMK24 (double)

Port Size	Bypass Rating	Indicator Options ¹	Part No.
SAE-20 O-Ring	None	A, B, C, E, F, H	P179609
1 1/4" SAE 4-Bolt Code 61	50 psi	A, B, C, E, F, H	P179582

¹Reference illustration on next page for service indicator styles.



Performance Data

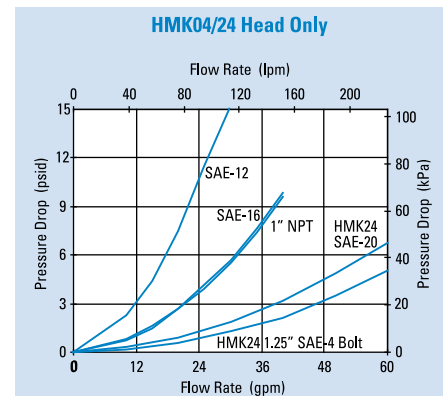
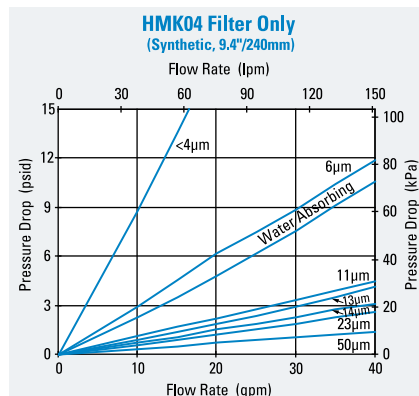
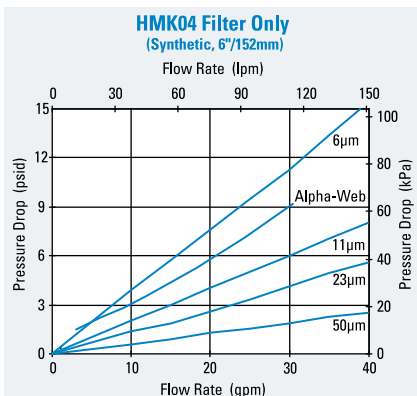

Head Choices for HMK04 (single)

Port Size	Bypass Rating	Standard Indicator Style & Location ^{1,2}	Indicator Options	Head Part No.
¾" NPT	25 psi / 172 kPa	None	None	P169317
		D (Visual), Left Side	None	P169310
SAE-12 O-Ring	25 psi / 172 kPa	None	None	P167473
		D (Visual), Left Side	None	P166387
	No Bypass	D (Visual), Left Side (25 psi)	None	P169320
		None	None	P165434
	No Bypass	D (Visual), Left Side (50 psi)	None	P173750
SAE-12 O-Ring (3 ports)	50 psi / 345 kPa	A (Electrical, P574719)	B, C, E, F, H	P167529
1" NPT	25 psi / 172 kPa	D (Visual), Both Sides	A, B, C, E, F, H	P166086
		None	None	P169309
		D (Visual), Left Side	None	P166416
SAE-16 O-Ring	15 psi / 100 kPa	None	A, B, C, E, F, H	P176569
SAE-16 O-Ring	25 psi / 172 kPa	None	None	P163681
		D (Visual), Left Side	None	P166417
		D (Visual), Both Sides	A, B, C, H	P166088
		E (Electrical, P177361)	None	P176568
		A (Electrical, P162400)	B, C, H	P165537
	No Bypass	D (Visual), Both Sides (25 psi)	A, B, C, F, H	P166664
		A (Electrical, P162400)	B, C, F, H	P166902
	50 psi / 345 kPa	D (Visual, Right Side)	All	P179381
	No Bypass	None	None	P164667
	50 psi / 345 kPa	None	None	P167201
		A (Electrical, P574719)	B, C, E, H	P166862
SAE-16 O-Ring	5 psi	D (Visual), Both Sides	All	P564850
1" NPT	No Bypass	D (Visual), Left Side (25 psiD)	None	P564484
1" NPT	25 psi / 172 kPa	D (Visual), Left Side (25 psiD)	None	P564485

NOTE:
Lubricate filter-to-head threads when installing new filter to prevent thread damage. Heavyweight gear lube is recommended.



Head Notes: Reference illustration below for indicator styles. Donaldson uses the inlet port as the reference point. "Left side," for instance, means that the indicator mounts on the side of the filter head that is on your left when you face the inlet port.

3-Port Head for Charge Pumps



The **P167529** head is designed with a 50 psi / 3.45 bar third port bypass valve that diverts all bypass flow back to the reservoir, instead of going straight through the head and into the system as it does in 2-ported heads. Unfiltered fluid is NOT allowed into the system in the case of plugged filters. Designed primarily for charge pump applications.

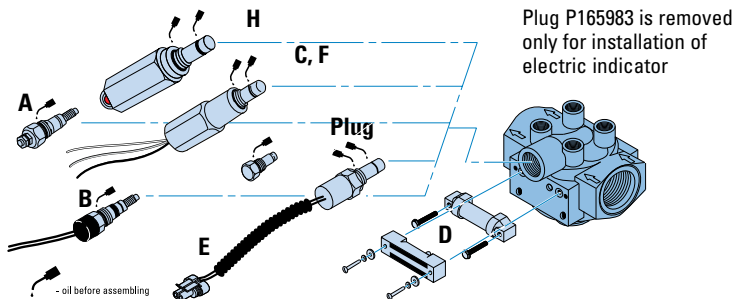

Service Indicator Choices

Use with Bypass Valve Pressure of:	Indicator Part No.	Style ³
Visual Models (non-electric)²		
15 psi / 103 kPa	P162642	D
25 psi / 172.5 kPa	P162696	D
50 psi / 345 kPa	P167580	D
N/A	P165984	(blank plate)
25 psi / 172.5 kPa	P165965	D Heavy-Duty
50 psi / 345 kPa	P574177	D Heavy-Duty
25 psi / 172.5 kPa	P575334	H Pop up
50 psi / 345 kPa	P575335	H Pop up

Indicator Notes
¹All electric models have a maximum operating temperature of 250°F / 121°C.
²All non-electric models have a maximum operating temperature of 180°F / 82°C.
³Complete details on all service indicators can be found in the accessories section.

Service Indicator Choices

Use with Bypass Valve Pressure of:	Indicator Part No.	Style ¹	Description
Electric Models¹			
15 psi / 103 kPa	P163601	A	Single post DC.
25 psi / 172.5 kPa	P163839	A	Single post DC. N.C.
25 psi / 172.5 kPa	P162400	A	Single post DC. N.O.
25 psi / 172.5 kPa	P171143	B	DC 2-wire.
25 psi / 172.5 kPa	P173944	C	AC/DC 3-wire.
50 psi / 345 kPa	P574719	A	Single post DC. N.O.
50 psi / 345 kPa	P574968	B	DC 2-wire.
50 psi / 345 kPa	P574967	E	DC 2-wire.
50 psi / 345 kPa	P575550	E	Deutsch N.O.
50 psi / 345 kPa	P575549	F	DC 3-wire.
50 psi / 345 kPa	P174396	C	AC/DC 3-wire.



HMK05/25

Max Flow: 50 gpm (189 lpm) / 100 gpm (379 lpm)



HMK05/25 DURAMAX® Spin-On Filters

Working Pressures to:

350 psi / 2415 kPa / 24.2 bar

Rated Static Burst to:

800 psi / 5520 kPa / 55.2 bar

Flow Range To:

HMK05: 50 gpm / 189 lpm

HMK25: 100 gpm / 379 lpm

Applications

- Case Drains
- Cooling Circuits
- Fluid Conditioning Systems
- Fuel Transfer
- Hydrostatic Charge Pumps
- Lube Oil Systems
- Power Transmissions
- Return Lines
- Side Loop Systems



Parallel Flow

Features

HMK05 (single) and HMK25 (double) Duramax spin-on filters are perfect for high-flow applications, featuring a heavy-duty steel body and die-cast top plate for added strength. A special head-to-canister O-Ring seal prevents leakage. Nitrile seals are standard. Fluorocarbon seals are available. Both models use the same replacement filters and have identical pressure ratings, so there's no need to inventory two different replacement filters. The HMK25 double filter head means twice the flow capability, with two filters to hold more contaminant. Take advantage of Donaldson's mix and match system of in-stock heads, housings and media choices for exactly what you need. Media options include wire mesh and Donaldson's exclusive Synteq™ synthetic media.

Beta Rating

- Performance to $\beta_{<4(c)}=1000$

Porting Size Options

- HMK05 1¼" NPT
- HMK05 SAE-20 O-Ring
- HMK25 1½" NPT
- HMK25 SAE-24 O-Ring
- HMK25 1½" SAE 4-Bolt Flange Code 61

Replacement Filter Lengths

- 7.6" / 193mm
- 11.63" / 295.4mm
- 14.2" / 361mm

Standard Bypass Ratings

- 25 psi / 173 kPa / 1.73 bar
- 50 psi / 345 kPa / 3.5 bar
- No Bypass

Assembly Weight

- 7.5 lbs / 3.4 kg (single)
- 16 lbs / 7.3 kg (double)

Operating Temperatures

- -20°F to 250°F / -29°C to 121°C (synthetic)
- -20°F to 225°F / -29°C to 107°C (cellulose)
- -20°F to 250°F / -29°C to 121°C (wire mesh)

Filter Collapse Ratings

- 200 psi / 13.8 bar

Housing Fatigue Strength Ratings*

- 100,000 Cycles:
0-350 psi / 0-2413 kPa / 24.1 bar
- 300,000 Cycles:
0-300 psi / 0-2068 kPa / 20.7 bar
- 1,000,000 Cycles:
0-250 psi / 0-1734 kPa / 17.3 bar

Filter Head Construction

- Standard Head Cast Aluminum
- Ductile Iron Available in HMK25

HMK05/25 Specification Illustrations

ASSEMBLY - SIDE VIEW

All dimensions are shown in inches [millimeters].

HMK25

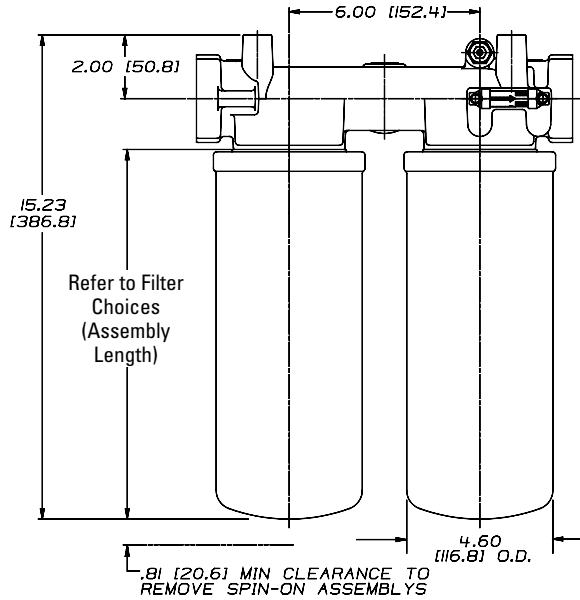

HMK05

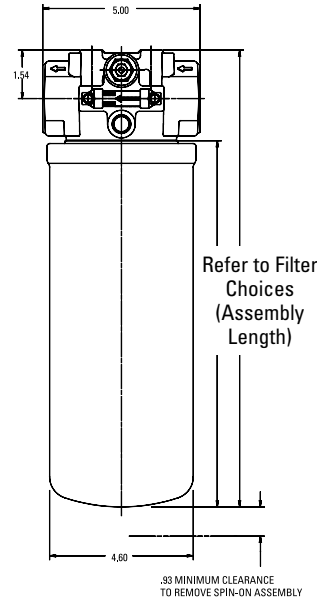

HEAD - TOP VIEW

HMK05

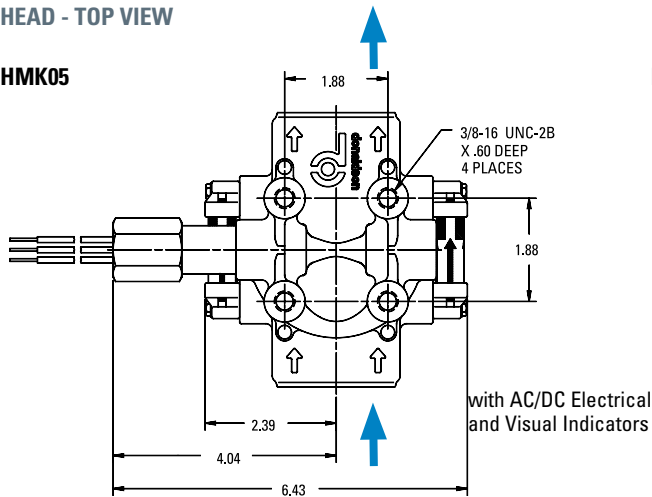

HMK25

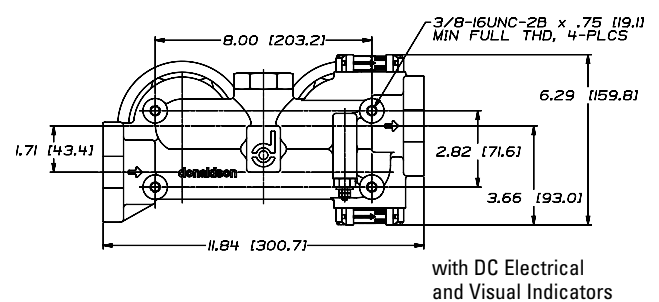
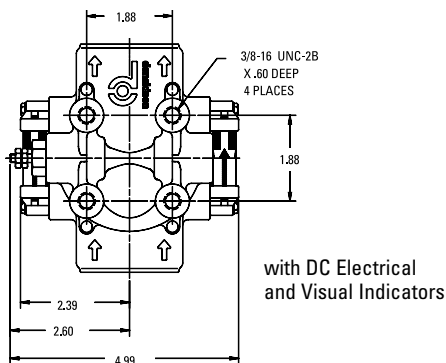
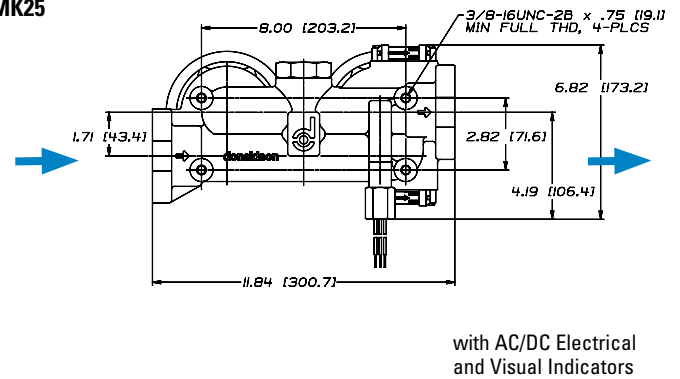



HMK05/25

Max Flow: 50 gpm (189 lpm) / 100 gpm (379 lpm)



HMK05/25 Components

Filter Choices

Media Type	$\alpha_{x(e)} = 1000$	$\beta_{x(e)} = 2$	$\beta_{x(e)} = 1000$	Length		Part No.	Comments
	Rating based on ISO 23369	Rating based on ISO 16889		in	mm		
Synteq Synthetic			<4 μm	14.2	361	P564468	'Fluorocarbon, epoxy. Compatible with water glycol.
			6 μm	11.6	294	P165675	
			5 μm	11.6	294	P171274	'Fluorocarbon, epoxy. Compatible with water glycol.
			6 μm	14.2	361	P179763	
Alpha-Web	10 μm			14.2	361	DBH0949	
Synteq Synthetic			11 μm	7.6	193	P176207	
			11 μm	11.6	294	P165659	
			13 μm	11.6	294	P573996	'Fluorocarbon, epoxy. Compatible with water glycol.
			11 μm	14.2	361	P170949	
			23 μm	7.6	193	P176208	
			23 μm	11.6	294	P165569	
			22 μm	11.6	294	P171276	'Fluorocarbon, epoxy. Compatible with water glycol.
			23 μm	14.2	361	P173789	
Water Absorbing		10 μm		11.6	294	P179075	Absorbs 300 ml water
			150 μm	11.6	294	P173943	

Service Parts

HMK05

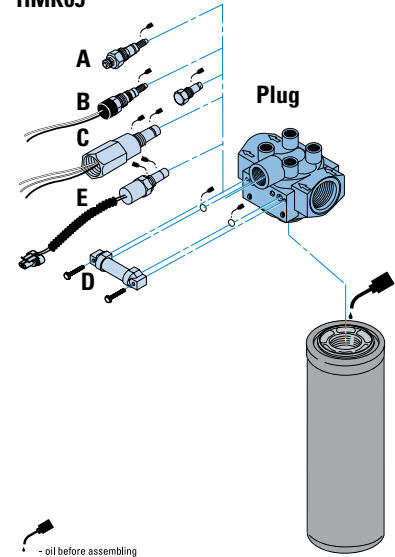

Filter Notes: Refer to table in the Technical Reference Guide for fluid compatibility with our filter media. Thread size is 1 3/4"-12 UNF-2B.

Filters with seals made of nitrile are appropriate for most applications involving petroleum oil. Filters with seals made of fluorocarbon are required when using diester, phosphate ester fluids, water glycol, water/oil emulsions and HWCF (high water content fluids) over 150°F. Donaldson offers both types.

Oil Service Indicator Options

Use with Bypass Valve Pressure of:	Indicator Part No.	Style ³	Description
Electric Models¹			
15 psi / 103 kPa	P163601	A	Single post DC.
25 psi / 172.5 kPa	P163839	A	Single post DC. N.C.
25 psi / 172.5 kPa	P162400	A	Single post DC. N.O.
25 psi / 172.5 kPa	P171143	B	DC 2-wire
25 psi / 172.5 kPa	P173944	C	AC/DC 3-wire
50 psi / 345 kPa	P574719	A	Single post DC. N.O.
50 psi / 345 kPa	P574968	B	DC 2-wire
50 psi / 345 kPa	P574967	E	DC 2-wire
50 psi / 345 kPa	P575550	E	Deutsch N.O.
50 psi / 345 kPa	P575549	F	DC 3-wire
50 psi / 345 kPa	P174396	C	AC/DC 3-wire
Visual Models (Non-Electric)²			
15 psi / 103 kPa	P162642	D	
25 psi / 172.5 kPa	P162696	D	
50 psi / 345 kPa	P167580	D	
N/A	P165984	(blank plate)	
25 psi / 172.5 kPa	P165965	D Heavy-duty	
50 psi / 345 kPa	P574177	D Heavy-duty	
25 psi / 172.5 kPa	P575334	H (Pop up)	
50 psi / 345 kPa	P575335	H (Pop up)	

HMK25

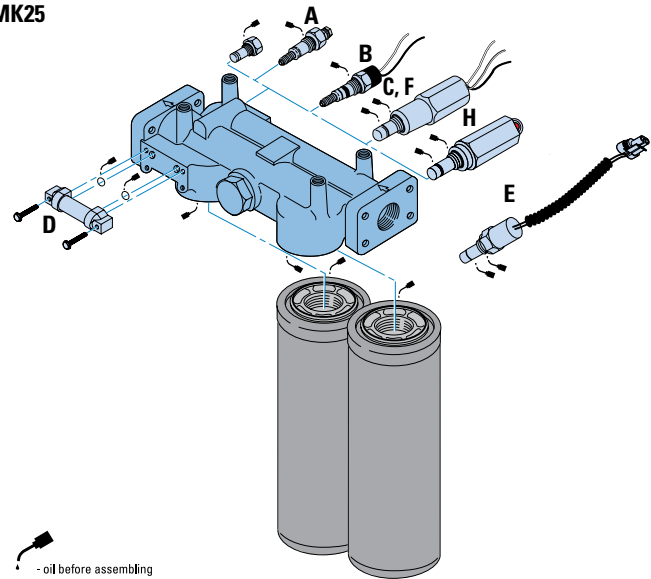

NOTE:

Lubricate filter-to-head threads when installing new filter to prevent thread damage. Heavyweight gear lube is recommended.

Indicator Notes ¹All electric models have a maximum operating temperature of 250°F/ 114°C. ²All non-electric models have a maximum operating temperature of 180°F/ 82°C. ³Complete details on all service indicators can be found in the accessories section.

Head Choices for HMK05 (single)

Port Size	Bypass Rating	Standard Indicator Style & Location ¹	Indicator Options ²	Part No.
1¼" NPT	25 psi / 172 KPa	D (Visual), Both Sides (25 psi)	A, B, C, E, F	P167294
1¼" NPT	25 psi / 172 kPa	A (Electrical) (25 psi)	A, B, C, E, F	P167621
	25 psi / 172 KPa	D (Visual), Left Side (25 psi)	D	P167622
SAE-20 O-Ring	25 psi / 172 KPa	D (Visual), Both Sides (25 psi)	A, B, C, E, F	P165973
	25 psi / 172 KPa	None	None	P167619
	50 psi / 345 KPa	D (Visual), Left Side, Blank Plate Right Side	A, B, C, E, F	P561885
	No Bypass	D (Visual), Both Sides (25 psi)	A, B, C, E, F	P166663
	No Bypass	D (Visual), Right Side (25 psi)	D	P564486
	No Bypass	D (Visual), Both Sides (50 psi)	A, B, C, E, F	P564858

Head Choices for HMK25 (dual)

Port Size	Bypass Rating	Indicator Style & Location ¹	Indicator Options ²	Part No.
1½" NPT	25 psi / 172 KPa	D (Visual), Left side only	A,B,C,E,F	P169985
1½" SAE 4-Bolt Flange	25 psi / 172 kPa	D (Visual), Both sides	A,B,C,E,F	P167296
	No Bypass	D (Visual), Both Sides	A,B,C,E,F	P169984
1½" SAE 4-Bolt Flange	50 psi / 345 kPa	Visual RH	A,B,C,E,F	P173812
SAE-24 O-Ring	25 psi / 172 kPa	D (Visual), Both sides	A,B,C,E,F	P167297
1½" SAE 4-Bolt Flange	50 psi / 345 kPa	Visual RH	A,B,C,E,F	P560855*

* Ductile Iron Construction

Head Choice for HMK05 (3rd port return)

Port Size	Bypass Rating	Indicator Style & Location ¹	Indicator Options ²	Part No.
1¼" SAE 4-Bolt Flange (3rd port: 1" SAE 4-Bolt)	50 psi / 345 kPa	None	A,B,C,E,F	P561924

Head Notes

¹Donaldson uses the inlet port as the reference point. "Left side," for instance, means the indicator mounts on the Left side when you face the inlet port.

²May be purchased separately.

*Complete details on all service indicators can be found in the accessories section.

NOTE:

Lubricate filter-to-head threads when installing new filter to prevent thread damage. Heavyweight gear lube is recommended.



Single Head



Dual Head

shop.donaldson.com



3-Port Head

The P561924 head is designed with a 50 psi / 3.45 bar third port bypass valve that diverts all bypass flow back to the reservoir, instead of going straight through the head and into the system as it does in 2-ported heads. Unfiltered fluid is NOT allowed into the system in the case of plugged filters. Designed primarily for charge pump applications.

Performance Data

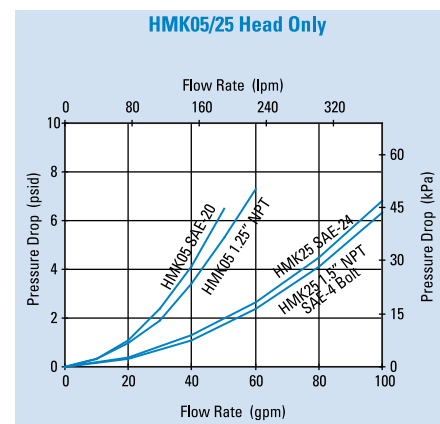
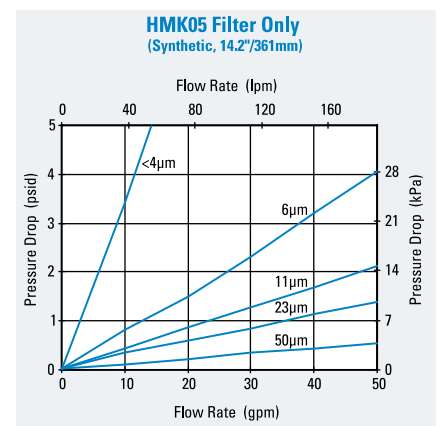
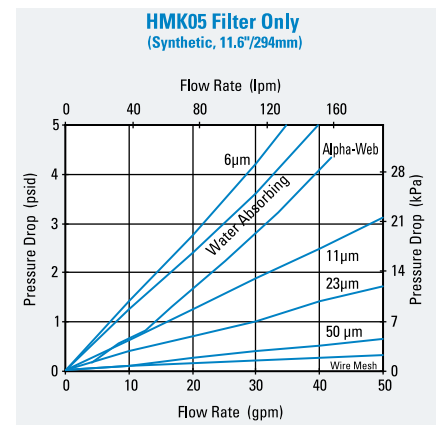
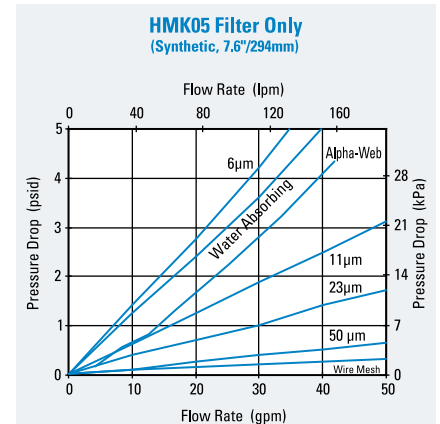



HNK04/05

Max Flow: 35 gpm (133 lpm) / 50 gpm (189 lpm)



HNK04/05 DURAMAX® Spin-On Filters

Working Pressures to:

HNK04: 500 psi / 3450 kPa / 34.5 bar

HNK05: 350 psi / 2415 kPa / 24.1 bar

Rated Static Burst to:

HNK04: 1000 psi / 6895 kPa / 69 bar

HNK05: 800 psi / 5515 kPa / 55 bar

Flow Range To:

HNK04: 35 gpm / 133 lpm

HNK05: 50 gpm / 189 lpm

Applications

- Case Drains
- Cooling Circuits
- Fluid Conditioning Systems
- Fuel Transfer
- Hydrostatic Charge Pumps
- Lube Oil Systems
- Power Transmissions
- Return Lines
- Side Loop Systems



Features

HNK Duramax® filters utilize a RadialSeal™ design – making servicing easier and providing a more reliable seal without having to torque to specification.

- Applications include hydrostatic charge side filtration, pilot circuits, power shift transmissions and kidney loop circuits.
- Utilizes Synteq™ filter media for high filtration efficiency and higher dust-holding capacity.
- Improved performance including higher burst, greater fatigue strength and longer filter life.

Beta Rating

- Performance to $\beta_{90} = 1000$

Porting Size Options

- HNK04: SAE-12, SAE-16 O-Ring
- HNK05: SAE-20 O-Ring

Replacement Filter Lengths

- 04 short: 5.97" / 151.7mm
- 04 long: 9.44" / 239.8mm
- 05 short: 11.63" / 295.4mm
- 05 long: 14.24" / 361.7mm

Standard Bypass Ratings

- 50 psi / 345 kPa / 3.5 bar
- No Bypass

Assembly Weight

- 04 short: 5.97" length - 3.95 lbs / 1.8 kg
- 04 long: 9.44" length - 4.7 lbs / 2.1 kg
- 05 short: 11.63" length - 7.35 lbs / 3.3 kg
- 05 long: 14.24" length - 8.0 lbs / 3.6 kg

Operating Temperatures

- -20° to 250°F (-29° to 121°C)

Filter Collapse Ratings

- 235 psi / 1621 kPa / 16.2 bar

HNK04/05 Specification Illustrations

HNK04 SPIN-ON ASSEMBLY - SIDE VIEW

All dimensions are shown in inches [millimeters].

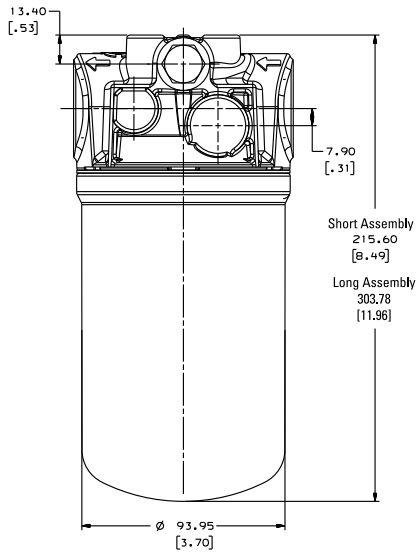

HNK05 SPIN-ON ASSEMBLY - SIDE VIEW

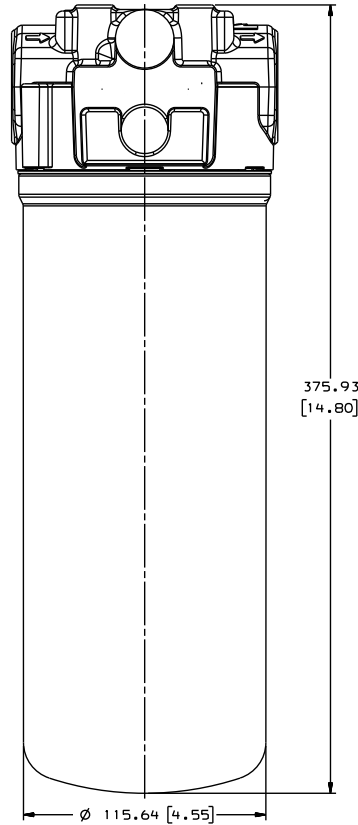

HNK04 HEAD - TOP VIEW

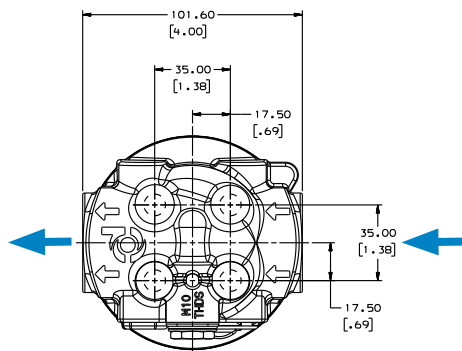

HNK05 HEAD - TOP VIEW

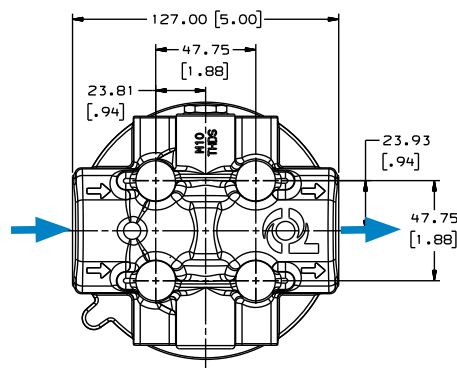



HNK04/05

Max Flow: 35 gpm (133 lpm) / 50 gpm (189 lpm)



HNK04/05 Components

Filter Choices for HNK04

Media Type	$\beta_{x(c)} = 1000$	Length		Part No.
	Rating based on ISO 16889	in	mm	
Synteq Synthetic	6 μm	5.97	151.7	P569203
	6 μm	9.44	239.8	P569204
	11 μm	5.97	151.7	P569205
	11 μm	9.44	239.8	P569206
	23 μm	9.44	239.8	P576047

Filter Choices for HNK05

Media Type	$\beta_{x(c)} = 1000$	Length		Part No.
	Rating based on ISO 16889	in	mm	
Synteq Synthetic	6 μm	11.63	295.4	P569209
	6 μm	14.24	361.7	P569210
	11 μm	11.63	295.4	P569211
	11 μm	14.24	361.7	P569212

Filter Notes: • Refer to table in the Technical Reference Guide for fluid compatibility with our filter media.

Head Choices for HNK04

Port Size	Bypass Rating	Part No.	Indicators	Style	Mounting Threads
SAE-12	50 psi / 3.5 bar	P568856	none	optional elect.	M10x1.5-6H
SAE-12	No bypass	P568857	none	optional elect.	M10x1.5-6H
SAE-16	50 psi / 3.5 bar	P568858	none	optional elect.	M10x1.5-6H
SAE-16	No bypass	P568859	none	optional elect.	M10x1.5-6H

Head Choices for HNK05

Port Size	Bypass Rating	Part No.	Indicators	Style	Mounting Threads
SAE-20	50 psi / 3.5 bar	P568860	none	optional elect.	M10x1.5-6H

Indicator Choices

Set Point/Type	Part No.	Description
50 psi / 345 kPa	P574719	Electric Single post DC
25 psi / 172 kPa	P575334	Visual Indicator, Pop up
50 psi / 345 kPa	P575335	Visual Indicator, Pop up



Performance Data

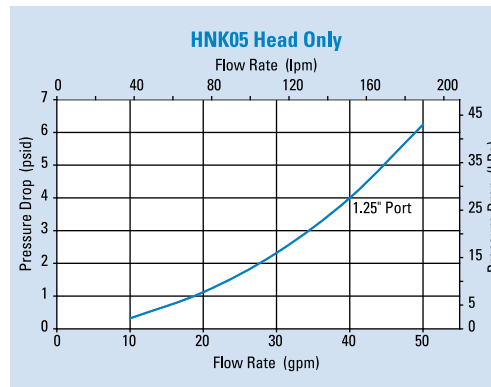
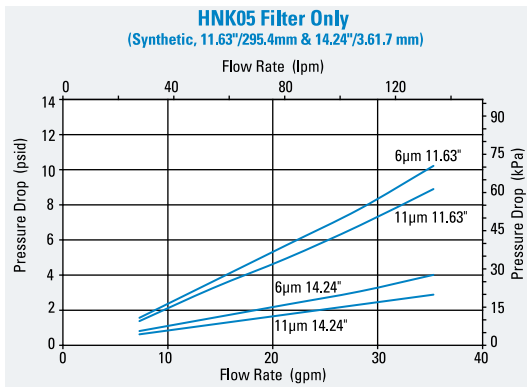
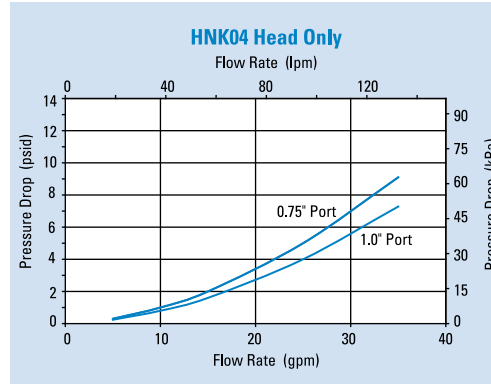
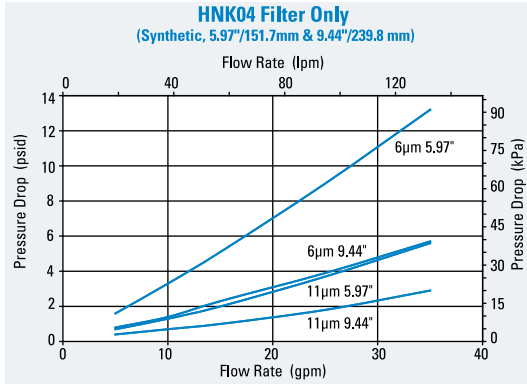

Service Parts

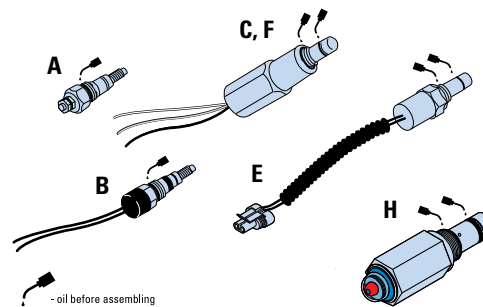
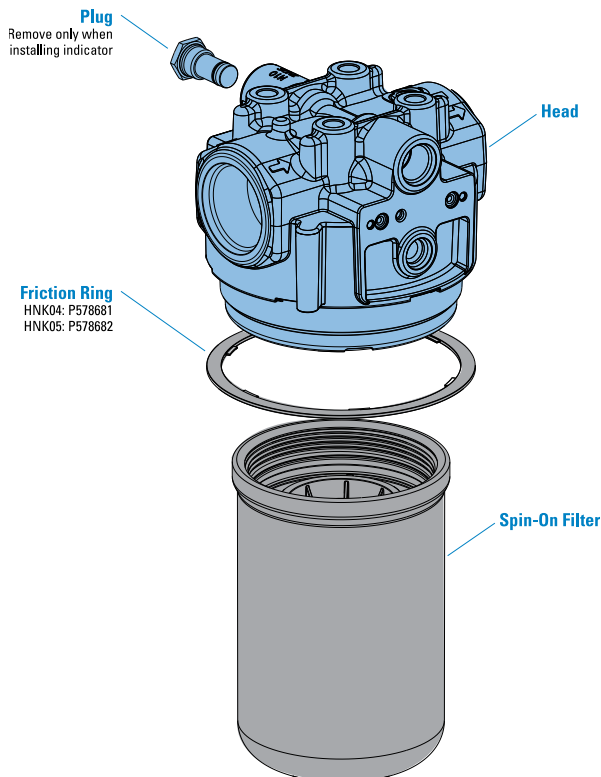

SERVICE PARTS NOTE:

Some service parts may not be stocked. Please contact your Donaldson sales representative for lead time details.



Our FLK hydraulic filtration systems are packed with innovative features that will deliver cleaner, mistake-proof filter servicing.

Features

The FLK assembly is a robust, reusable housing with a disposable cartridge design. The versatile filter head accommodates multiple housing lengths. Raised hand grips make it easy to remove the housing from the head without special servicing tools. The oil drain port on the bottom of the housing allows cleaner, easier servicing. The filter tabs lock into place – simplifying positioning during reassembly.

A unique sealing technology protects systems from harmful ingressed contaminants and cross contamination. The RadialSeal™ interface increases surface area to provide a robust connection with superior vibration resistance. Extended surface area gives advanced filtration performance. Donaldson's proprietary Synteq™ media technology delivers better pressure drop and contaminant holding capacity than standard filter media.

- Robust 4-point mount
- Optional 2-point mount
- Oil drain port
- Heads have one side machined/plugged for indicator

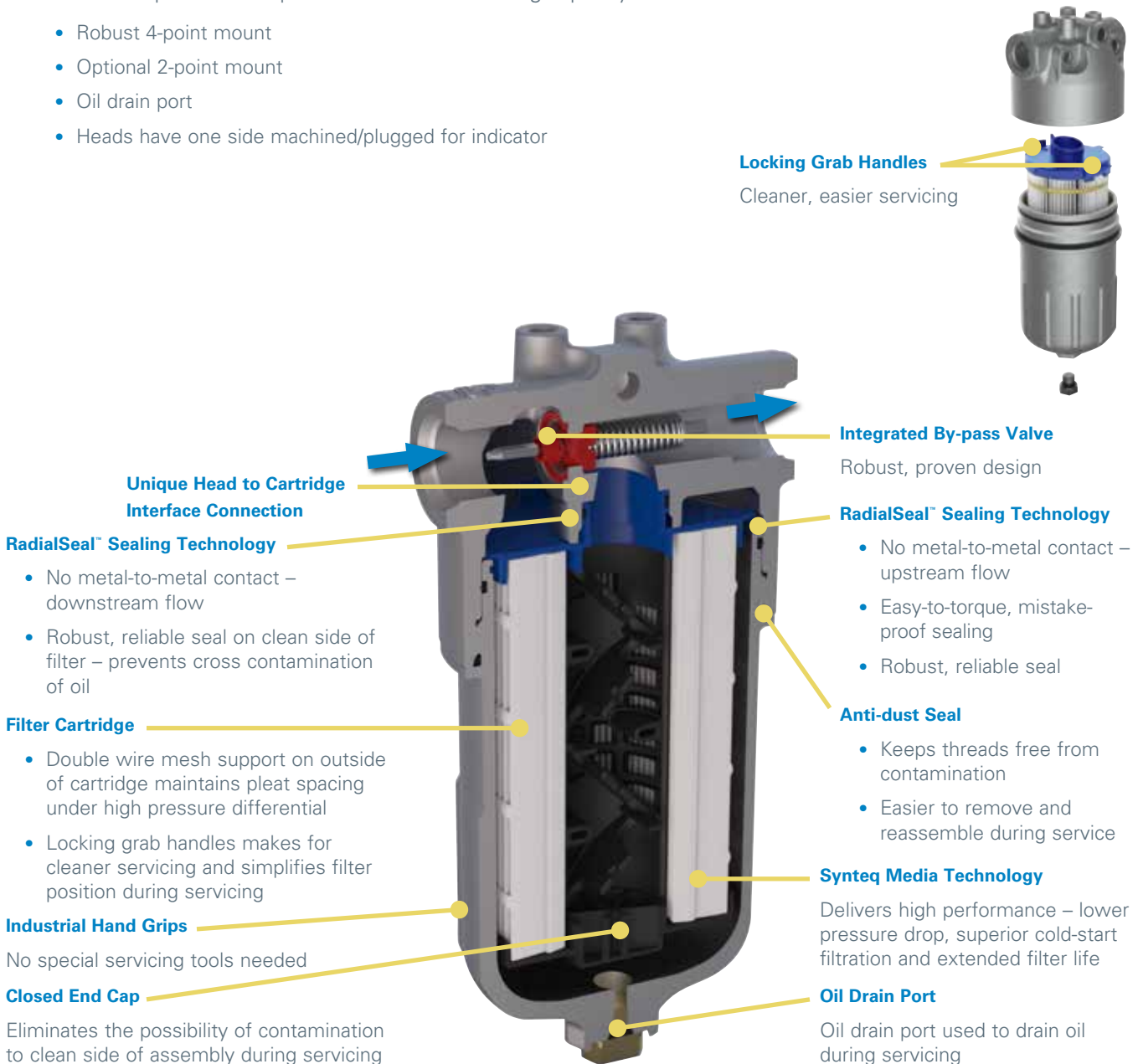

Locking Grab Handles
Cleaner, easier servicing

Integrated By-pass Valve
Robust, proven design

RadialSeal™ Sealing Technology

- No metal-to-metal contact – upstream flow
- Easy-to-torque, mistake-proof sealing
- Robust, reliable seal

Anti-dust Seal

- Keeps threads free from contamination
- Easier to remove and reassemble during service

Synteq Media Technology

Delivers high performance – lower pressure drop, superior cold-start filtration and extended filter life

Oil Drain Port

Oil drain port used to drain oil during servicing

Unique Head to Cartridge Interface Connection

RadialSeal™ Sealing Technology

- No metal-to-metal contact – downstream flow
- Robust, reliable seal on clean side of filter – prevents cross contamination of oil

Filter Cartridge

- Double wire mesh support on outside of cartridge maintains pleat spacing under high pressure differential
- Locking grab handles makes for cleaner servicing and simplifies filter position during servicing

Industrial Hand Grips

No special servicing tools needed

Closed End Cap

Eliminates the possibility of contamination to clean side of assembly during servicing

FLK90 In-Line Cartridge Filters

Working Pressures to:

580 psi / 4002 kPa / 40 bar

Rated Static Burst to:

2000 psi / 13,790 kPa / 138 bar

Flow Range To:

40 gpm / 151 lpm

Applications

- Hydrostatic Charge Pumps
- Hydrostatic Transmission
- Pilot Control Circuits



IMPORTANT SERVICE INSTRUCTIONS:

To prevent thread damage when installing new filter, fully lubricate the entire thread and O-Ring surface with a Molybdenum-containing gear oil or anti-seize paste such as Schaeffer #214S Supreme One 80W-140 gear oil or Dow Corning Molykote P-37 anti-seize paste.

Beta Rating

- Performance to $\beta_{<60>} = 1000$

Porting Size Options

- SAE-12 O-Ring
- SAE-16 O-Ring

Replacement Filter Lengths

- 4.21" / 107mm
- 8.23" / 209mm

Standard Bypass Ratings

- 50 psi / 345 kPa / 3.5 bar
- No bypass

Assembly Weight

- Long Housing: 2.33 kg / 5.14 lbs
- Short Housing: 1.82 kg / 4.01 lbs

Operating Temperatures

- -40° to 250°F (-40° to 121°C)

Filter Collapse Ratings

- 145 psid / 1000 kPa / 10 bar (standard)



FLK90

Max Flow: 40 gpm (151 lpm)



FLK Specification Illustrations

LONG ASSEMBLY - SIDE VIEW

All dimensions are shown in millimeters [inches].

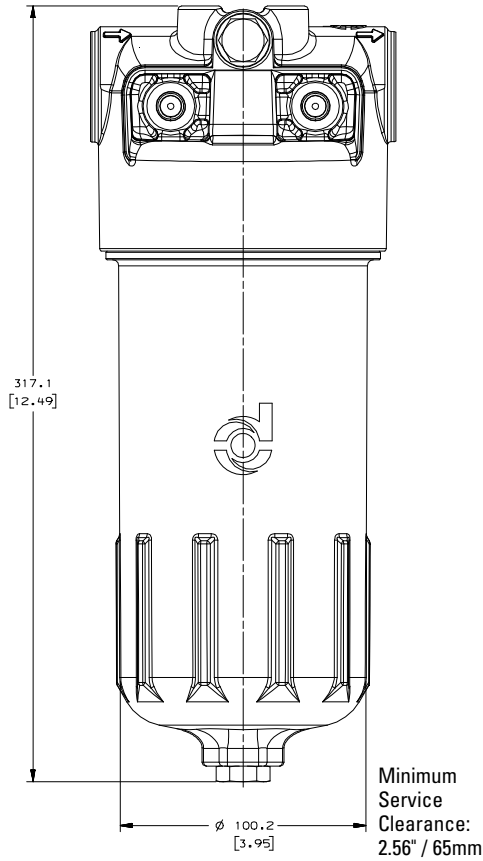

SHORT ASSEMBLY - SIDE VIEW

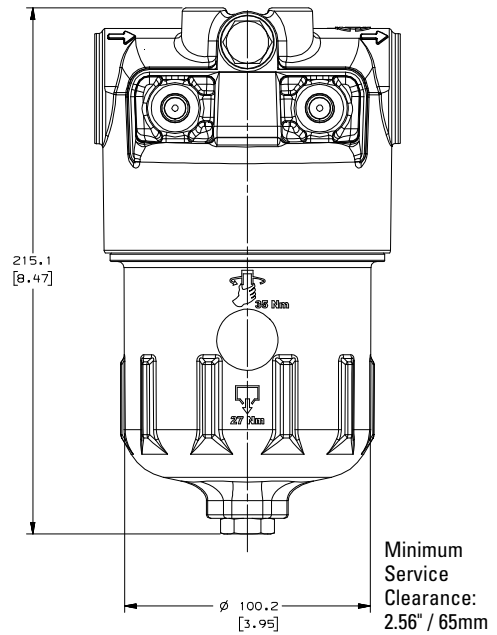

HEAD - TOP VIEW

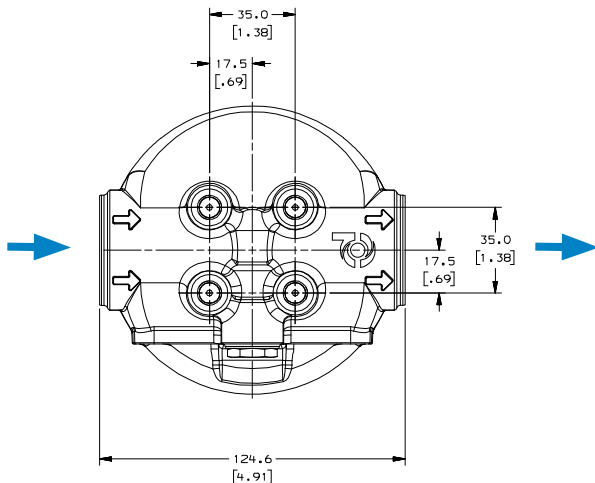

FLK90 Components

Filter Choices

Media Type	$\beta_{x(e)} = 1000$	Length		Part No.
	Rating based on ISO 16889	in	mm	
Short Length Assembly				
Synteq Synthetic	6 μm	4.21	107	P767128
	11 μm	4.21	107	P766987
	15 μm	4.21	107	P767129
Long Length Assembly				
Synteq Synthetic	6 μm	8.23	209	P767130
	11 μm	8.23	209	P766959
	15 μm	8.23	209	P767131
	25 μm	8.23	209	P585121

Head Choices

Part No.	Port Connections	Bypass Valve
P574994	SAE-12	50 psi (3.4 bar) bypass
P584982	SAE-12	25 psi (1.7 bar) bypass
P584981	SAE-12	No bypass
P574996	SAE-16	50 psi (3.4 bar) bypass
P584984	SAE-16	25 psi (1.7 bar) bypass
P584983	SAE-16	No bypass

Housing Choices

Part No.	Comments
P766990	Short length assembly
P766961	Long length assembly

Service Indicator Choices

Use with Bypass Valve Pressure of:	Indicator Part No.	Style ²	Description
Electric Models¹			
50 psi / 345 kPa	P574719	A	Single post DC. N.O.
50 psi / 345 kPa	P574968	B	DC 2-wire.
50 psi / 345 kPa	P574967	E	DC 2-wire.
50 psi / 345 kPa	P575550	E	Deutsch N.O.
50 psi / 345 kPa	P575549	F	DC 3-wire.
50 psi / 345 kPa	P174396	C	AC/DC 3-wire.
25 psi / 172.5 kPa	P575334	H	Visual pop up
25 psi / 172.5 kPa	P163839	A	Single post DC. N.C.
25 psi / 172.5 kPa	P162400	A	Single post DC. N.O.
25 psi / 172.5 kPa	P171143	B	DC 2-wire.
25 psi / 172.5 kPa	P173944	C	AC/DC 3-wire.
50 psi / 345 kPa	P575335	H	Visual pop up

Indicator Notes

¹All electric models have a maximum operating temperature of 250°F / 121°C.

²Complete details on all service indicators can be found in the accessories section.

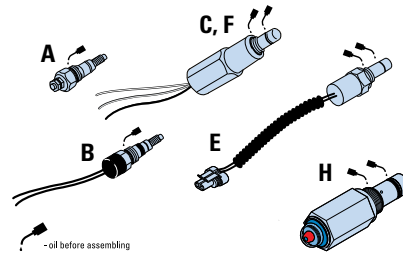

Performance Data

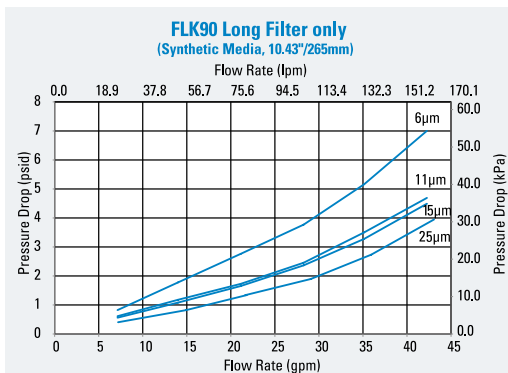
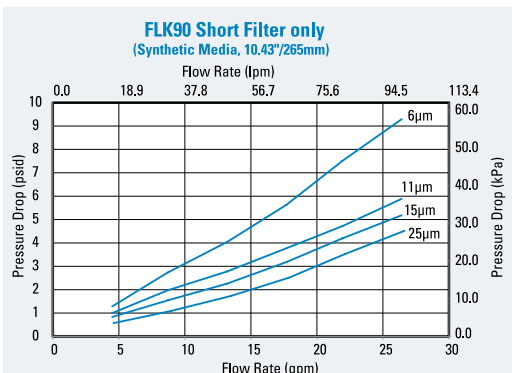
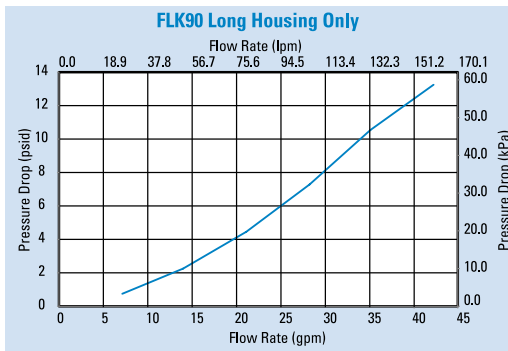
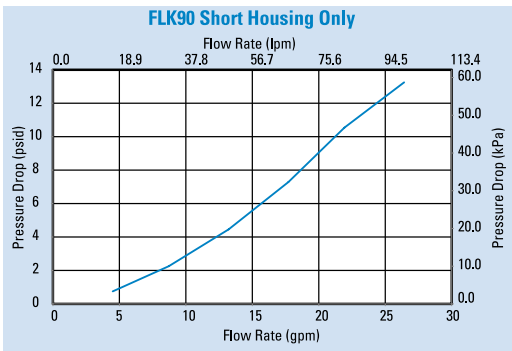



FLK110

Max Flow: 42 gpm (159 lpm)



FLK110 In-Line Cartridge Filters

Working Pressures to:

435 psi / 3001 kPa / 30 bar

Rated Static Burst to:

1300 psi / 8970 kPa / 90 bar

Flow Range To:

42 gpm / 159 lpm

Applications

- Hydrostatic Charge Pumps
- Hydrostatic Transmission
- Pilot Control Circuits



IMPORTANT SERVICE INSTRUCTIONS:

To prevent thread damage when installing new filter, fully lubricate the entire thread and O-Ring surface with a Molybdenum-containing gear oil or anti-seize paste such as Schaeffer #214S Supreme One 80W-140 gear oil or Dow Corning Molykote P-37 anti-seize paste.

Beta Rating

- Performance to $\beta_{-60} = 1000$

Porting Size Options

- SAE-20 O-Ring

Replacement Filter Lengths

- 7.4" / 187.9mm
- 10.43" / 264.9mm

Standard Bypass Ratings

- 50 psi / 345 kPa / 3.5 bar
- No bypass

Assembly Weight

- Long Housing: 1.34 kg / 2.95 lb
- Short Housing: 1.01 kg / 2.22 lb

Operating Temperatures

- -40° to 250°F (-40° to 121°C)

Filter Collapse Ratings

- 145 psid / 1000 kPa / 10 bar (standard)

FLK Specification Illustrations

LONG ASSEMBLY - SIDE VIEW

All dimensions are shown in millimeters [inches].

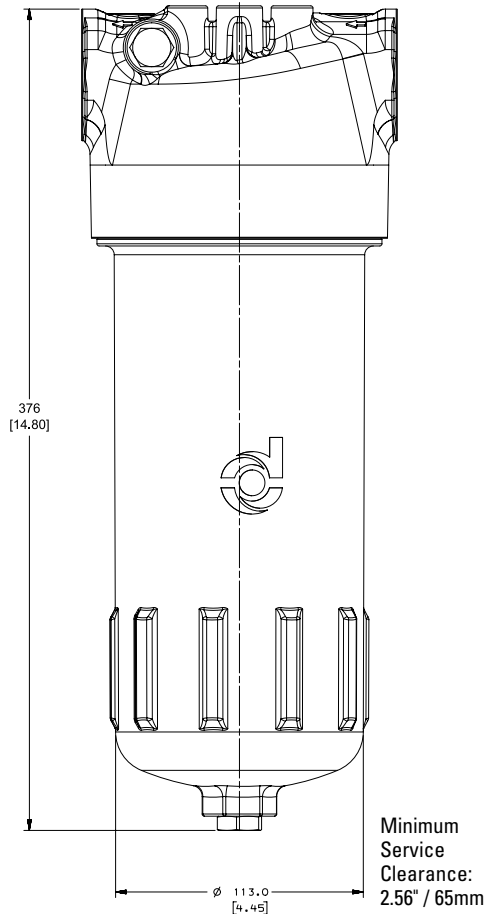

SHORT ASSEMBLY - SIDE VIEW

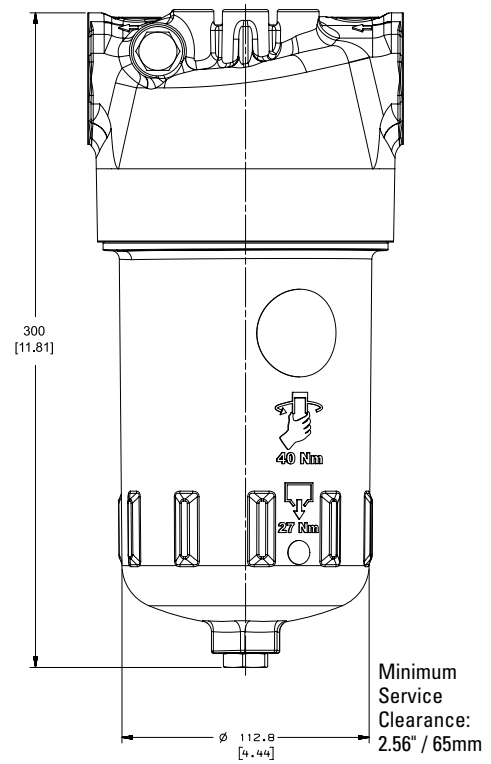

HEAD - TOP VIEW

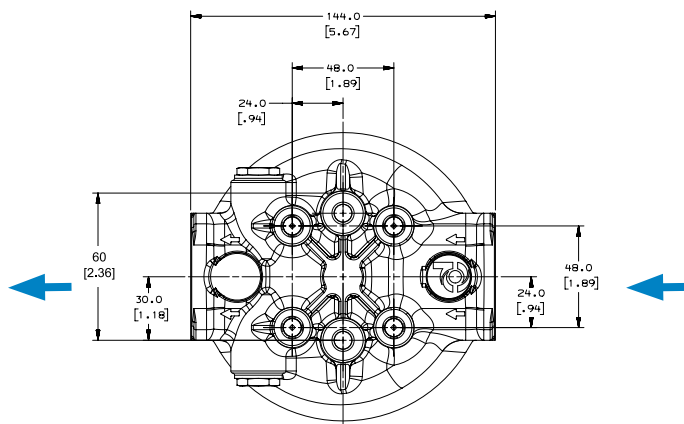



FLK110

Max Flow: 42 gpm (159 lpm)



FLK110 Components

Filter Choices

Media Type	$\beta_{2(c)} = 1000$	Length		Part No.
	Rating based on ISO 16889	in	mm	
Short Length Assembly				
Synteq Synthetic	6 μm	7.4	187	P766847
	11 μm	7.4	187	P766813
	25 μm	7.4	187	P585122
Long Length Assembly				
Synteq Synthetic	6 μm	10.43	265	P767010
	11 μm	10.43	265	P766811
	15 μm	10.43	265	P767011
	25 μm	10.43	265	P585123

Head Choices

Part No.	Port Connections	Bypass Valve
P766831	SAE-20	50 psi (3.4 bar) bypass
P584986	SAE-20	25 psi (1.7 bar) bypass
P584985	SAE-20	No bypass

Housing Choices

Part No.	Comments
P766812	Short length assembly
P766810	Long length assembly

Service Indicator Choices

Use with Bypass Valve Pressure of:	Indicator Part No.	Style ²	Description
Electric Models¹			
50 psi / 345 kPa	P574719	A	Single post DC. N.O.
50 psi / 345 kPa	P574968	B	DC 2-wire.
50 psi / 345 kPa	P574967	E	DC 2-wire.
50 psi / 345 kPa	P575550	E	Deutsch N.O.
50 psi / 345 kPa	P575549	F	DC 3-wire.
50 psi / 345 kPa	P174396	C	AC/DC 3-wire.
25 psi / 172.5 kPa	P575334	H	Visual pop up
25 psi / 172.5 kPa	P163839	A	Single post DC. N.C.
25 psi / 172.5 kPa	P162400	A	Single post DC. N.O.
25 psi / 172.5 kPa	P171143	B	DC 2-wire.
25 psi / 172.5 kPa	P173944	C	AC/DC 3-wire.
50 psi / 345 kPa	P575335	H	Visual pop up

Indicator Notes

¹All electric models have a maximum operating temperature of 250°F / 121°C.

²Complete details on all service indicators can be found in the accessories section.

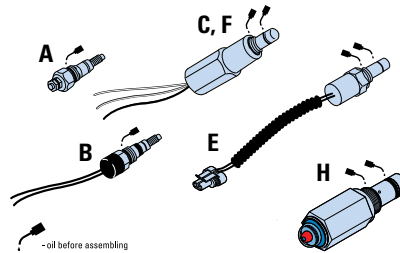

Performance Data

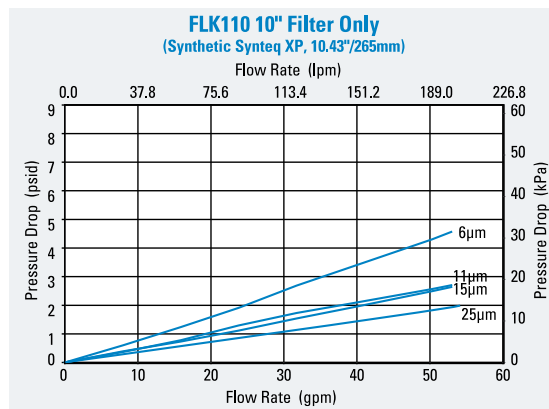
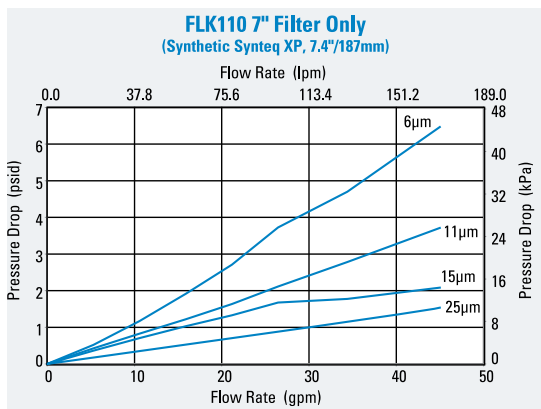
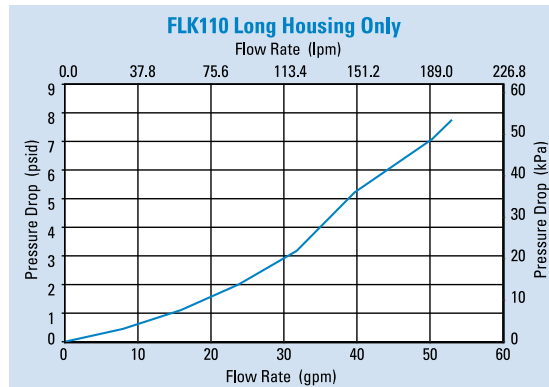
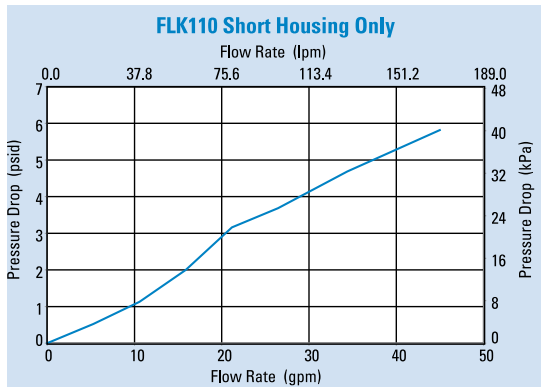

FLK125 In-Line Cartridge Filters

Working Pressures to:

508 psi / 3505 kPa / 35.1 bar

Rated Static Burst to:

2000 psi / 13,790 kPa / 138 bar

Flow Range To:

85 gpm / 322 lpm

Applications

- Hydrostatic Charge Pumps
- Hydrostatic Transmission
- Pilot Control Circuits



IMPORTANT SERVICE INSTRUCTIONS:

To prevent thread damage when installing new filter, fully lubricate the entire thread and O-Ring surface with a Molybdenum-containing gear oil or anti-seize paste such as Schaeffer #214S Supreme One 80W-140 gear oil or Dow Corning Molykote P-37 anti-seize paste.

Beta Rating

- Performance to $\beta_{<610>}=1000$

Porting Size Options

- 2" SAE 4 Bolt Flange Code 61

Replacement Filter Lengths

- 10.85" / 275.7mm

Standard Bypass Ratings

- 50 psi / 345 kPa / 3.5 bar

Assembly Weight

- Long Housing: 4.76 kg / 10.50 lbs

Operating Temperatures

- -40° to 250°F (-40° to 121°C)

Filter Collapse Ratings

- 145 psid / 1000 kPa / 10 bar (standard)



FLK125

Max Flow: 85 gpm (322 lpm)

FLK Specification Illustrations

LONG ASSEMBLY - SIDE VIEW

All dimensions are shown in millimeters [inches].

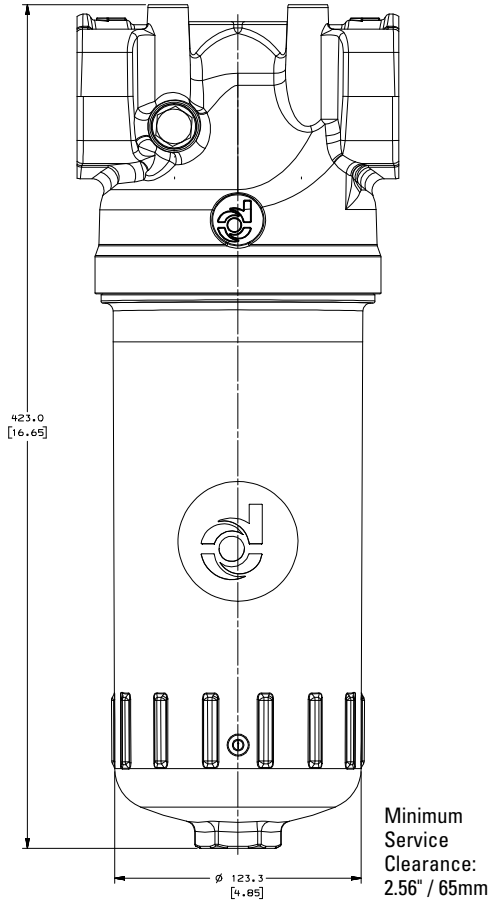

HEAD - TOP VIEW

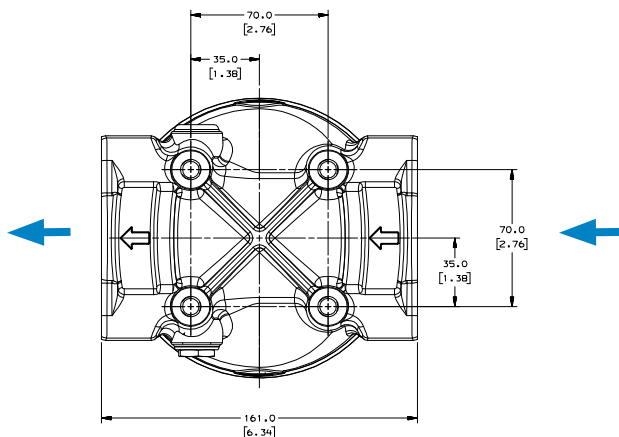

FLK125 Components

Filter Choices

Media Type	$\beta_{x(c)} = 1000$	Length		Part No.
	Rating based on ISO 16889	in	mm	
Synteq Synthetic	6 μm	10.74	272.7	P767084
	11 μm	10.74	272.7	P767104
	15 μm	10.74	272.7	P767106
	25 μm	10.74	272.7	P585124

Head Choices

Part No.	Port Connections	Bypass Valve
P767095	2" SAE 4 bolt	50 psi (3.4 bar) bypass
P584988	2" SAE 4 bolt	25 psi (1.7bar) bypass
P584987	2" SAE 4 bolt	No bypass

Housing Choices

Part No.	Comments
P767089	Long length assembly

Service Indicator Choices

Use with Bypass Valve Pressure of:	Indicator Part No.	Style ²	Description
Electric Models¹			
50 psi / 345 kPa	P574719	A	Single post DC. N.O.
50 psi / 345 kPa	P574968	B	DC 2-wire.
50 psi / 345 kPa	P574967	E	DC 2-wire.
50 psi / 345 kPa	P575550	E	Deutsch N.O.
50 psi / 345 kPa	P575549	F	DC 3-wire.
50 psi / 345 kPa	P174396	C	AC/DC 3-wire.
25 psi / 172.5 kPa	P575334	H	Visual pop up
25 psi / 172.5 kPa	P163839	A	Single post DC. N.C.
25 psi / 172.5 kPa	P162400	A	Single post DC. N.O.
25 psi / 172.5 kPa	P171143	B	DC 2-wire.
25 psi / 172.5 kPa	P173944	C	AC/DC 3-wire.
50 psi / 345 kPa	P575335	H	Visual pop up

Indicator Notes

¹All electric models have a maximum operating temperature of 250°F / 121°C.

²Complete details on all service indicators can be found in the accessories section.

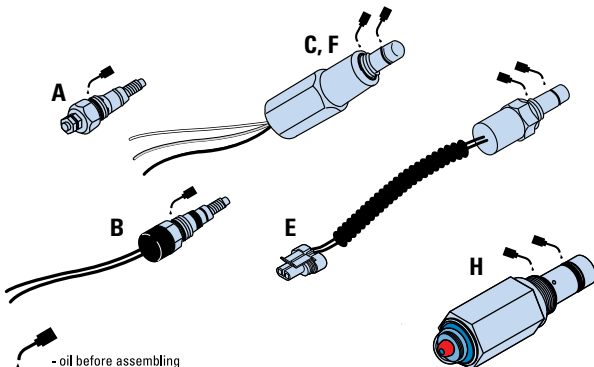

Performance Data

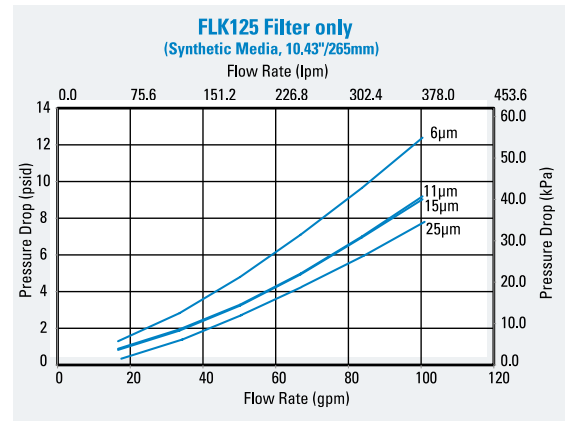
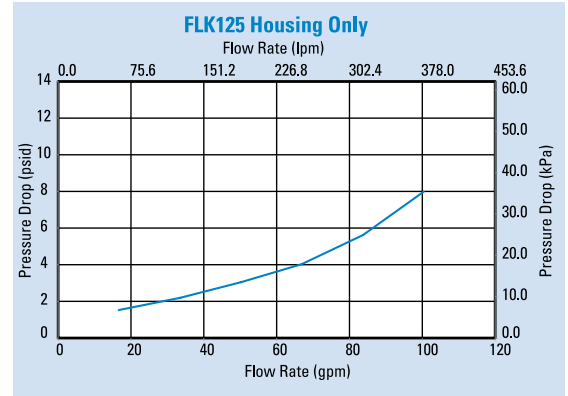



DPK350

Max Flow: 100 gpm (379 lpm)

DPK350 In-Line Cartridge Filters

Working Pressures to:

350 psi / 2400 kPa / 24 bar

Rated Static Burst to:

700 psi / 4800 kPa / 48 bar

Flow Range To:

100 gpm / 379 lpm

Applications

- In-plant Systems
- Process Fluids
- Lube Oil Systems

Features

DPK350 duplex filter assemblies allow continuous filtration during filter servicing to avoid machine shutdown. The DPK350 duplex design combines lighter weight aluminum heads with durable steel housings for a high-performance assembly. Choose between optional features such as no by-pass, by-pass valve, visual indicators or combination electrical/visual indicators for a customized assembly that best fits the needs of your specific application. Filter performance ranges from 5μ to 25μ at beta 1000 and high collapse elements are available at 5μ and 27μ , offering additional flexibility to achieve the filtration level your system requires.

- Head Material: Anodized Aluminum Alloy
- Housing Material: Steel
- Optional visual and visual / electric indicators
- Self locking transfer valve
- Automatic bleed-over valve



Beta Rating

- Performance to $\beta_{slc1} = 1000$

Porting Size Options

- 1-1/2" SAE 4-Bolt Flange Code 61

Replacement Filter Lengths

- 14.62" / 371mm

Standard Bypass Ratings

- 50 psi / 345 kPa / 3.5 bar
- No bypass

Assembly Weight

- 44 lbs / 20 kg

Operating Temperatures

- -40° to 250°F (-40° to 121°C)

Filter Collapse Ratings

- 300 psid / 207 kPa / 21 bar (standard)
- 3045 psid / 2100 kPa / 210 bar (high collapse)

DPK350 Specification Illustrations

ASSEMBLY - SIDE VIEW

All dimensions are shown in millimeters [inches].

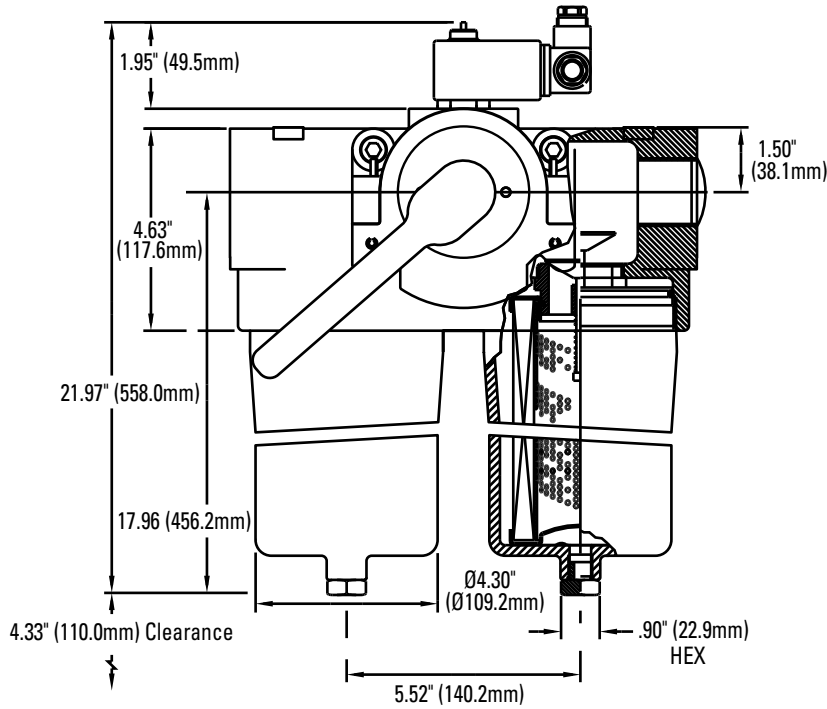

The handle shifts fluid flow from one filter to the other.

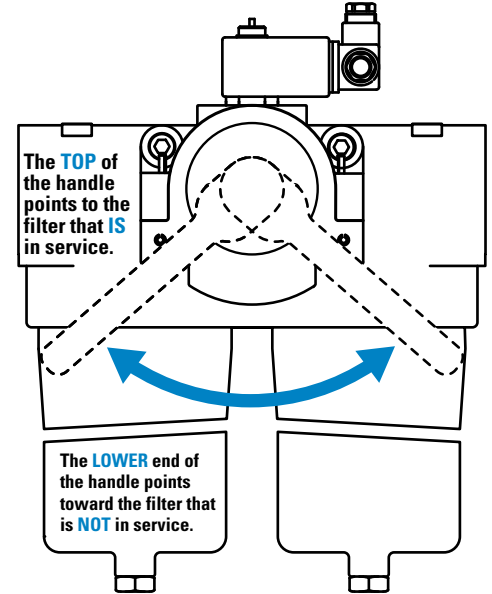

HEAD - TOP VIEW

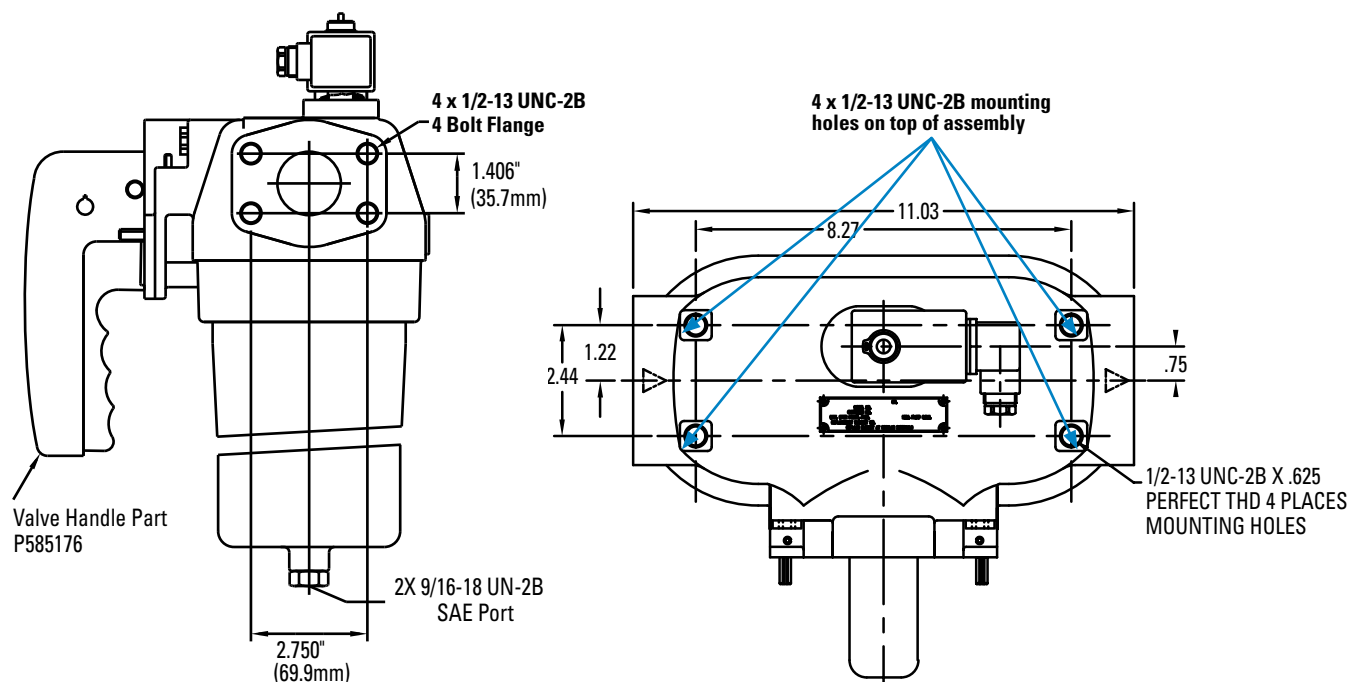



DPK350

Max Flow: 100 gpm (379 lpm)



DPK350 Components

Filter Choices

Media Type	$\beta_{x(c)} = 1000$	Length		Part No.	Comments
	Rating based on ISO 16889	in	mm		
DT Synthetic	5 μ m	14.62	371	P567101	
	5 μ m	14.69	373	P560716	High collapse
	8 μ m	14.62	371	P567102	
	12 μ m	14.62	371	P567103	
	23 μ m	14.62	371	P567104	
	27 μ m	14.69	373	P560718	High collapse

Assembly Choices

Part No.	Port Connections	Bypass Valve	Comments
P577024	1-1/2" SAE 4-bolt flange code 61	No bypass	Filter elements not included with assembly.
P577025	1-1/2" SAE 4-bolt flange code 61	50 psi (3.4 bar) bypass	Filter elements not included with assembly.

Service Indicator Choices

Use with Bypass Valve Pressure of:	Indicator Part No.	Seal Material	Connector Style
Visual / Electric Models			
50 psi / 345 kPa	P577029	Fluorocarbon seal	Hirschman
Visual Models			
50 psi / 345 kPa	P577028	Fluorocarbon seal	Manual reset

Service Part Choices

Part No.	Description
P585176	Valve Handle



Performance Data

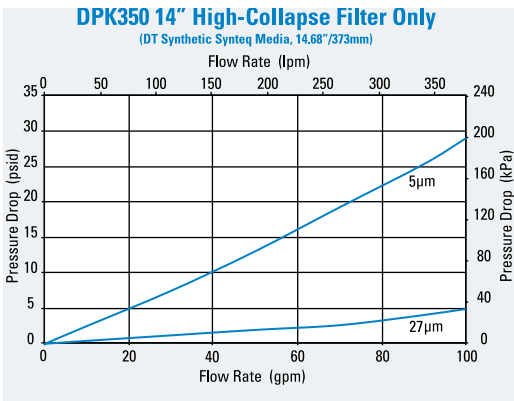
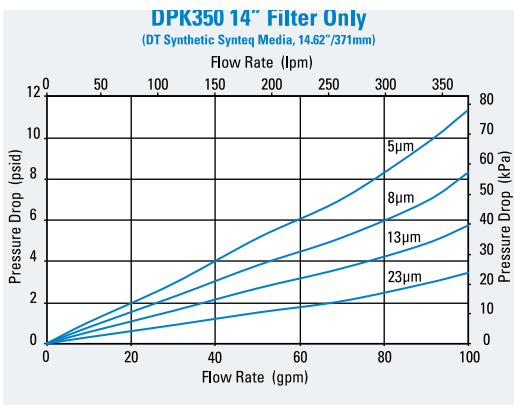
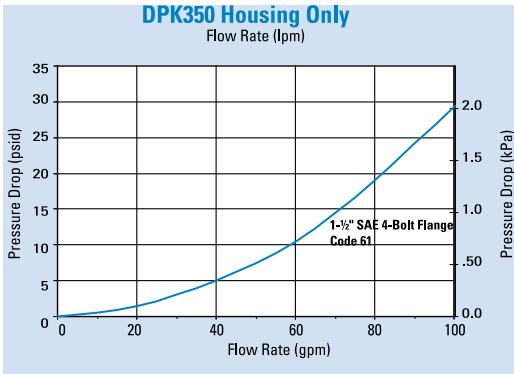



HDK06

Max Flow: 150 gpm (568 lpm)



HDK06 In-Line/Tank Mount Filters

Working Pressures to:

350 psi / 2415 kPa / 24.1 bar

Rated Static Burst to:

500 psi / 3450 kPa / 34.5 bar

Flow Range To:

150 gpm / 568 lpm

Applications

- Cooling Circuits
- Fluid Conditioning Systems
- Lube Oil Systems
- Return Lines
- Suction Lines

Features

HDK06 filters come in two styles: In-line and tank mount. Both styles feature a die cast aluminum head and steel body for strength and durability; service is made easier with a single, center retention bolt on top of the head. Filter flow is inside to outside. Nitrile seals are standard.

HDK06 assemblies come complete with our $\beta_{9(c)}=1000$ rated Synteq™ filter cartridge. Other ratings are available, depending on your cleanliness requirements. HDK06 comes with an easy-to-read visual service indicator.



In-line model shown

Beta Rating

- Performance to $\beta_{24(c)}=1000$

Porting Size Options

- 2½" NPT

Replacement Filter Lengths

- 16.00" / 406mm

Standard Bypass Ratings

- 25 psi / 172.5 kPa / 1.7 bar

Assembly Weight

- 39.25 lbs / 18 kg

Operating Temperatures

- -20°F to 250°F
- -29°C to 121°C

Filter Collapse Ratings

- 100 psid / 690 kPa / 6.9 bar

HDK06 Specification Illustrations

ASSEMBLY - SIDE VIEW

All dimensions are shown in inches [millimeters].

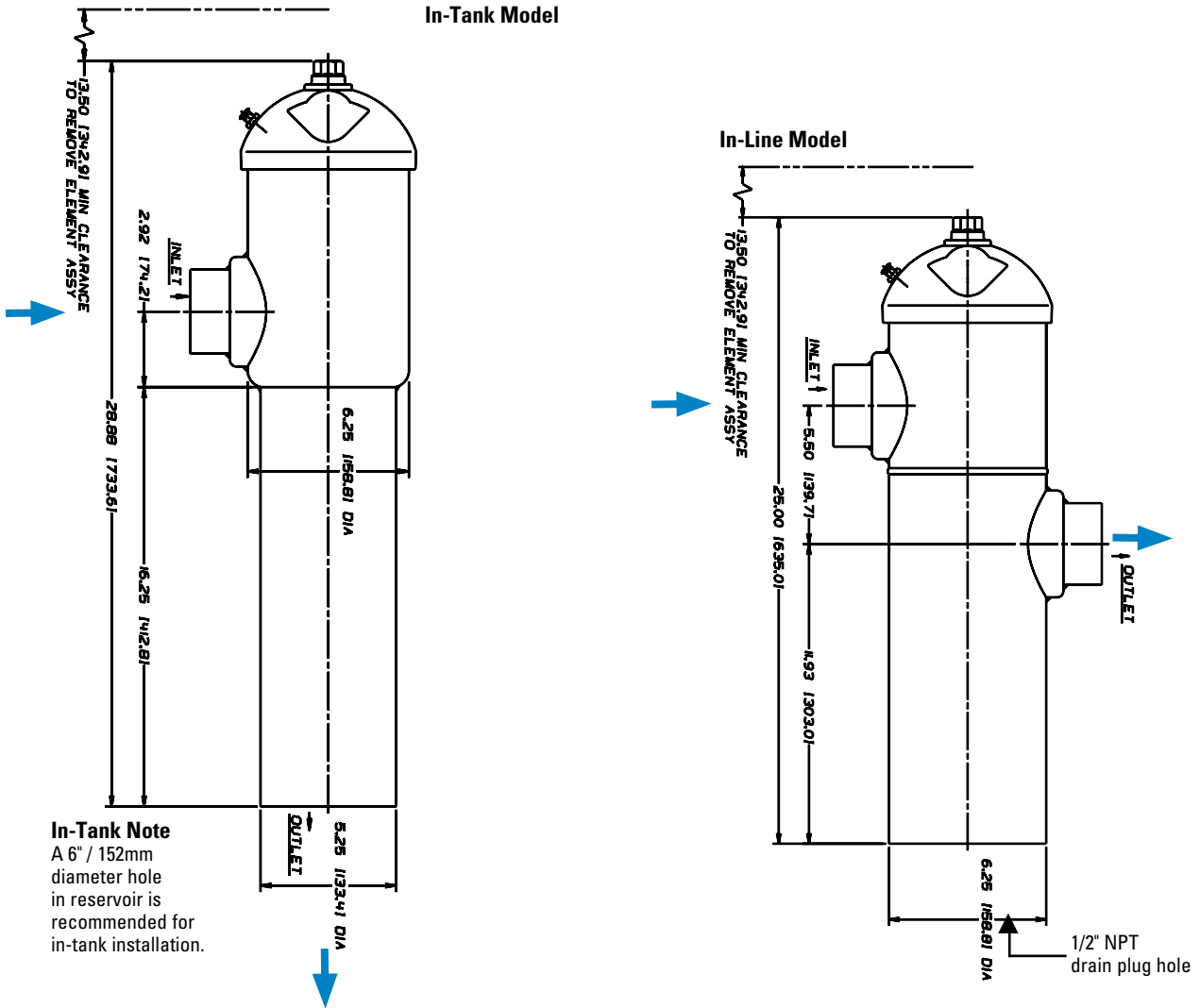

HEAD - TOP VIEW

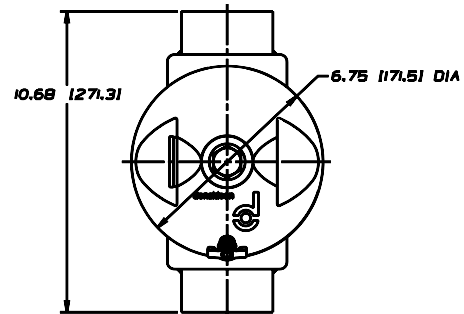
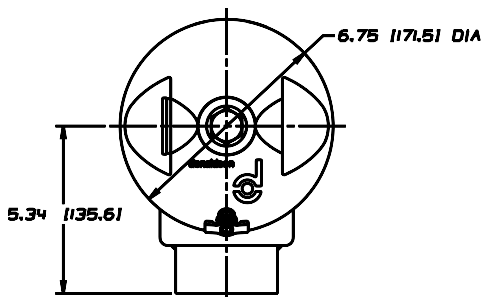



HDK06

Max Flow: 150 gpm (568 lpm)



HDK06 Components

Filter Choices

Media Type	$\beta_{x(c)} = 2$	$\beta_{x(c)} = 1000$	Length		Part No.
	Rating based on ISO 16889		in	mm	
Synteq Synthetic		<4 μm	16.00	406	P161016
		6 μm	16.00	406	P165628
		11 μm	16.00	406	P176221
		22 μm	16.00	406	P161571
		23 μm	16.00	406	P164699
		50 μm	16.00	406	P166597
Wire Mesh	150 μm		11.6	294	P160700

Filter Notes

Standard HDK06 replacement filters have nitrile seals, which are appropriate for most applications involving petroleum oil. Filters with seals made of fluorocarbon are required when using diester, phosphate ester fluids, water glycol, water/oil emulsions, and HWCF (high water content fluids) over 150°F. HDK06 filters are inside to outside reverse flow 4.39" (112mm) OD. Refer to the table in the Technical Reference Guide for fluid compatibility with our filter media.

Assembly Choices

Style	Part No.	Port Size	Bypass Rating	Indicator	Includes Filter Cartridge
In-Tank	K060173	2½" NPT	25 psi / 172.5 kPa	Visual	P176221
In-Line	K060160	2½" NPT	25 psi / 172.5 kPa	Visual	P176221

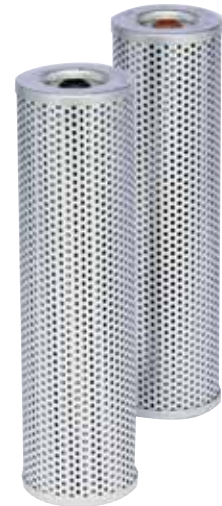

Performance Data

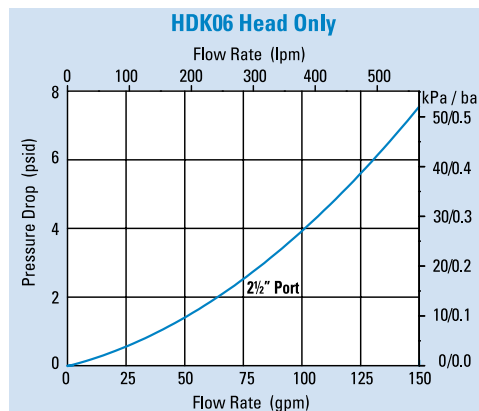
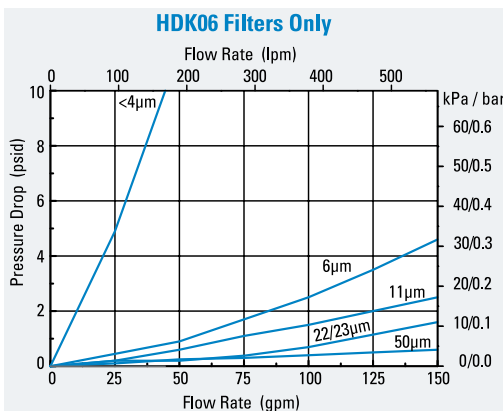

HDK06 Service Parts

SERVICE PARTS NOTE:

Some service parts may not be stocked. Please contact your Donaldson sales representative for lead time details.

Optional Tee Handle
for Easier Servicing

The first step in changing the HDK06 cartridge is loosening the top nut with a wrench. Our optional tee handle makes this job easier. The P160135 kit, comprised of the handle, an O-Ring, and a clip ring, replaces the entire top nut assembly.

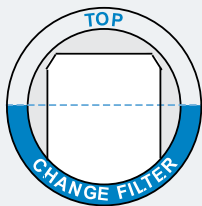
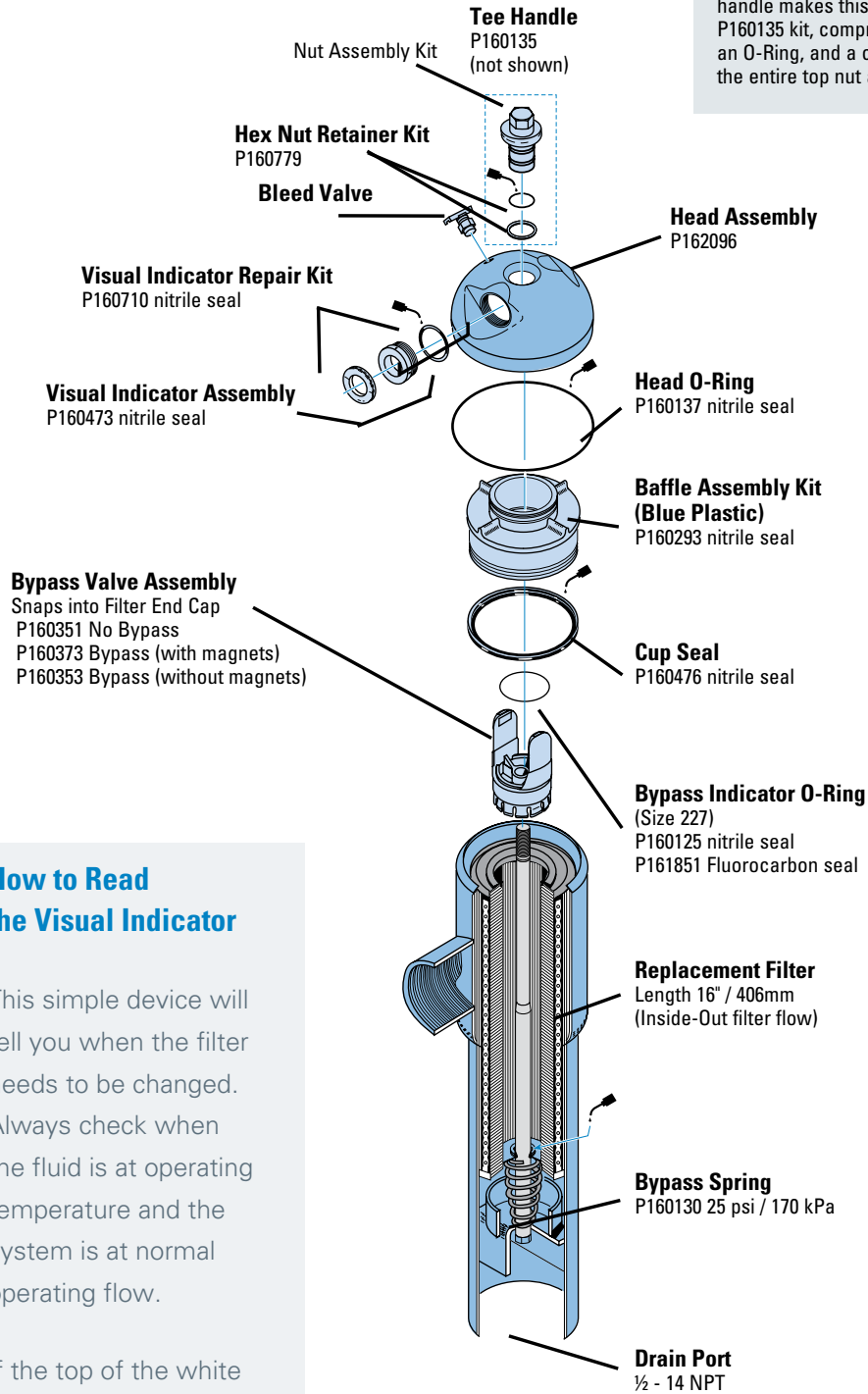

Filter OK

How to Read the Visual Indicator

This simple device will tell you when the filter needs to be changed. Always check when the fluid is at operating temperature and the system is at normal operating flow.

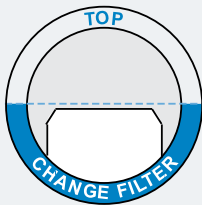

Filter Needs Service

If the top of the white panel is below the lower half of the window, the filter needs servicing.



W041

Max Flow: 300 gpm (1135 lpm)

W041 In-Line Cartridge Filters

Working Pressures to:

500 psi / 3450 kPa / 34.5 bar

Rated Static Burst to:

1500 psi / 10,342 kPa / 103.5 bar

Flow Range To:

300 gpm / 1135 lpm

Applications

- Fluid Conditioning Systems
- In-Plant Systems
- Lube Oil Systems

Features

The W041 high flow filter combines the best features of a base-mounted assembly; several inlet port options, top cover filter servicing for ease of maintenance and a wide selection of service indicators. The W041 all-aluminum head design and plated steel cylinder provides a strong, durable, and dependable unit. We offer standard features like deep pleat filters for higher dirt holding capacity and our standard Donaldson DT 4-layer media filter construction. This technology, combined with many other standard features, is ideal for today's applications in pulp and paper, power generation and steel mill applications. Thermal lockout and surge control are two key features incorporated in many of the differential pressure indicators.

- Large T-handle for fast servicing without tools
- Wide range of indicator options
- Two filter length options for design flexibility
- Base material: aluminum
- Cylinder material: steel
- Cover material: cast iron
- Two drain plugs in base
- Bleed/fill plug in cover



Beta Rating

- Performance to $\beta_{<4(\mu)}=1000$

Porting Size Options

- 2" or 2½"SAE 4-Bolt Flange Code 61

Replacement Filter Lengths

- 16.74" / 425.3mm
- 38.62" / 980.9mm

Standard Bypass Ratings

- 50 psi / 345 kPa / 3.5 bar

Housing Weight

- 16.74": 48.5 lbs / 22.0 kg
- 38.62": 86.2 lbs / 39.2 kg

Operating Temperatures

- -20°F to 250°F / -29° to 121°C

Filter Collapse Ratings

- 150 psid / 1034 kPa / 10.3 bar (standard)

W041 Specification Illustrations

ASSEMBLY - SIDE VIEW

All dimensions are shown in millimeters [inches].

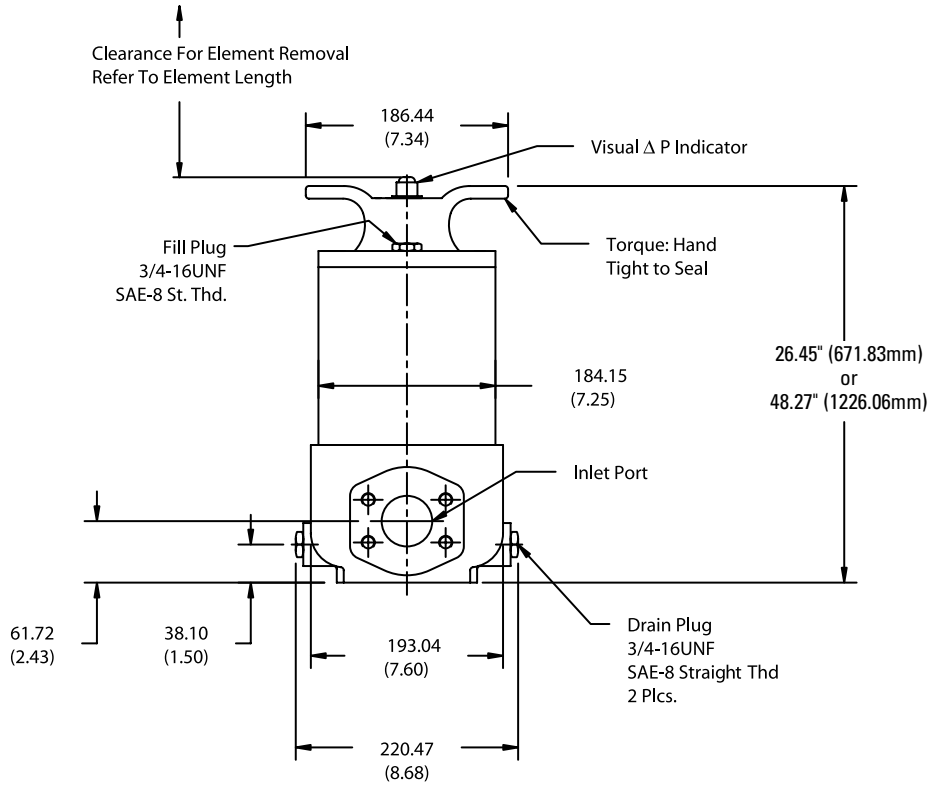

HEAD - BOTTOM VIEW

1/2-13UNC-2B Thd x 19.05 (.75)
Full Thd 4 Mounting Holes
(For All Port Options)

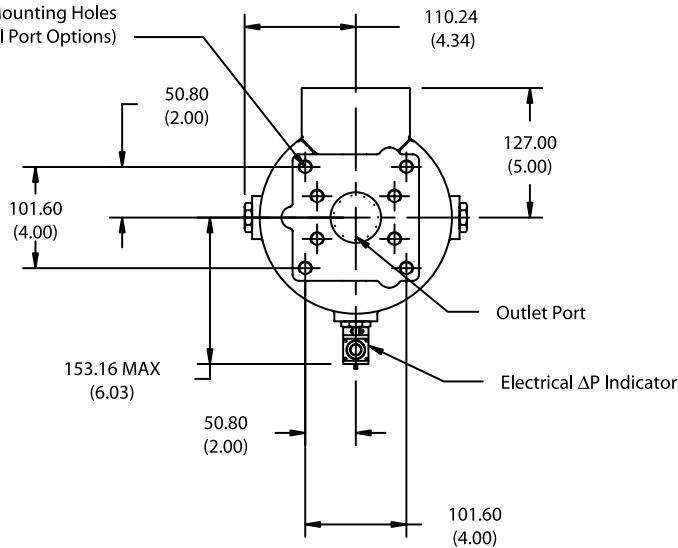



W041

Max Flow: 300 gpm (1135 lpm)



W041 Components

Filter Choices

Media Type	$\beta_{x(c)} = 1000$	Length		Part No.	Comments
	Rating based on ISO 16889	in	mm		
DT Synthetic	<4 μm	16.74	425	P566239	DT-8300-16-2UM
	5 μm	16.74	425	P566240	DT-8300-16-5UM
	8 μm	16.74	425	P566241	DT-8300-16-8UM
	12 μm	16.74	425	P566242	DT-8300-16-14UM
	23 μm	16.74	425	P566243	DT-8300-16-25UM
	<4 μm	38.62	981	P566244	DT-8300-39-2UM
	5 μm	38.62	981	P566245	DT-8300-39-5UM
	8 μm	38.62	981	P566246	DT-8300-39-8UM
	12 μm	38.62	981	P566247	DT-8300-39-14UM
	23 μm	38.62	981	P566248	DT-8300-39-25UM
	<4 μm	16.10	409	P566249	DT-8310-16-2UM
	5 μm	16.10	409	P566250	DT-8310-16-5UM
	8 μm	16.10	409	P566251	DT-8310-16-8UM
	12 μm	16.10	409	P566252	DT-8310-16-14UM
	23 μm	16.10	409	P566253	DT-8310-16-25UM
	<4 μm	37.94	964	P566254	DT-8310-39-2UM
	5 μm	37.94	964	P566255	DT-8310-39-5UM
	8 μm	37.94	964	P566256	DT-8310-39-8UM
	12 μm	37.94	964	P566257	DT-8310-39-14UM
	23 μm	37.94	964	P566258	DT-8310-39-25UM
Water Absorbing	10 μm	37.94	964	P578277	Absorbs 2,000 ml water @ 25 psid

Filter Notes: All Donaldson DT filters utilize glass fiber media with an acrylic-based resin system for the ultimate in chemical compatibility. All Donaldson DT filters are potted and seam-sealed with acrylic-based adhesives. Standard collapse designs are double wire-backed using acrylic-coated steel mesh for maximum pleat support and dirt capacity. Extended life designs are double wire-backed using acrylic-coated steel mesh. Fluorocarbon seals are standard on all Donaldson DT filters.

Filter Assembly Choices

Size	Rating	Material	Indicator Port	Housing Length	Assembly Length	Part No.
2" SAE 4 Bolt Flange Code 61	50 psi / 3.45 bar	Fluorocarbon	Port Machined & Plugged	16" (406.4mm)	26.45" (671.8mm)	P574218
2-1/2" SAE 4 Bolt Flange Code 61	50 psi / 3.45 bar	Fluorocarbon	Port Machined & Plugged	39" (990.6mm)	48.27" (1226.1mm)	P574219
2" SAE 4 Bolt Flange Code 61	50 psi / 3.45 bar	Fluorocarbon	Port Machined & Plugged	39" (990.6mm)	48.27" (1226.1mm)	P575920
2-1/2" SAE 4 Bolt Flange Code 61	50 psi / 3.45 bar	Fluorocarbon	Port Machined & Plugged	16" (406.4mm)	26.45" (671.8mm)	P575921

Indicator Choices

Indicator Pressure Setting	Connector Style	Seal Material	Part No.	Thermal Lockout	Surge Control	Reset
Visual Pop-up Models						
35 psi / 241 kPa	NA	Nitrile	P572347	No	No	Auto
35 psi / 241 kPa	NA	Nitrile	P572348	Yes	Yes	Manual
35 psi / 241 kPa	NA	Fluorocarbon	P567456	Yes	Yes	Manual
Electrical / Visual Models						
35 psi / 241 kPa	Hirschman	Nitrile	P572327	No	No	Auto
35 psi / 241 kPa	Hirschman	Nitrile	P572384	Yes	Yes	Manual
35 psi / 241 kPa	Hirschman	Fluorocarbon	P567458	Yes	Yes	Manual
35 psi / 241 kPa	Brad Harrison	Nitrile	P572385	Yes	Yes	Manual
35 psi / 241 kPa	3 wire flying leads	Nitrile	P572349	No	No	Auto
Electrical Models						
35 psi / 241 kPa	Hirschman	Nitrile	P572359	No	No	Auto

Service Part Choices

Part No.	Description
X011156	Head/Bowl/Housing Seal Kit - nitrile
X011157	Head/Bowl/Housing Seal Kit - fluorocarbon

Performance Data

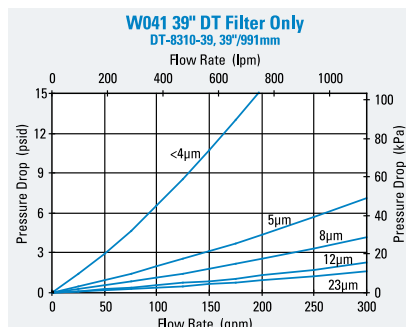
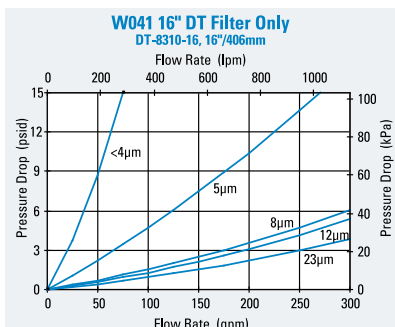
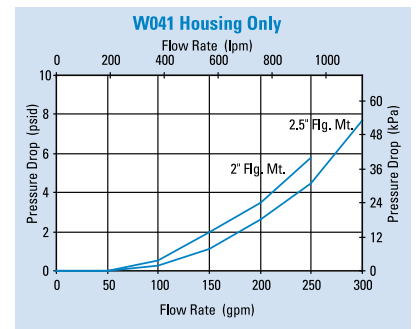
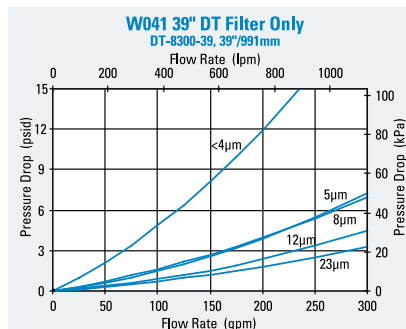
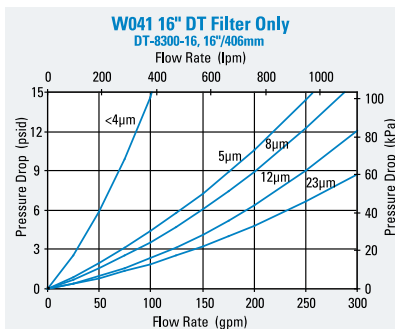



HFK08

Max Flow: 300 gpm (1135 lpm)



HFK08 In-Line/Tank Mount Filters

Working Pressures to:

350 psi / 2415 kPa / 24.1 bar

Rated Static Burst to:

500 psi / 3450 kPa / 34.5 bar

Flow Range To:

300 gpm / 1135 lpm

Applications

- Fluid Conditioning Systems
- Lube Oil Systems
- Return Lines
- Side Loop Systems
- Suction Lines

Features

HFK08 is available in two styles: in-line and in-tank. Both styles feature a cast aluminum head and steel body for maximum strength and durability. Its single, center retention bolt simplifies servicing. Flow is from inside to outside of the filter cartridge. Three in-stock HFK08 models offer our proprietary Synteq™ synthetic media designed especially for liquid filtration. A wider range of filter media is available to purchase separately, as are fluoroelastomer seals. A visual service indicator is built into the HFK08 head.



**In-line
model shown**

Beta Rating

- Performance to $\beta_{<40}₁₀₀₀$

Porting Size Options

- 3" NPT
- SAE-20 O-Ring

Replacement Filter Lengths

- 18.00" / 457mm

Standard Bypass Ratings

- 25 psi / 172.5 kPa / 1.7 bar

Assembly Weight

- 55.4 lbs / 25.12 kg

Operating Temperatures

- -20°F to 250°F
- -29°C to 121°C

Filter Collapse Ratings

- 75 psi / 517 kPa / 5.2 bar (synthetic)
- 100 psi / 689 kPa / 6.9 bar (wire mesh)

HFK08 Specification Illustrations

ASSEMBLY - SIDE VIEW

All dimensions are shown in inches [millimeters].

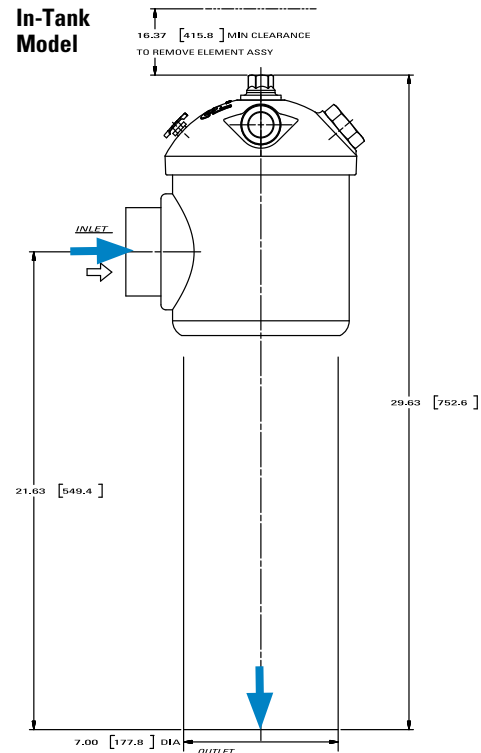
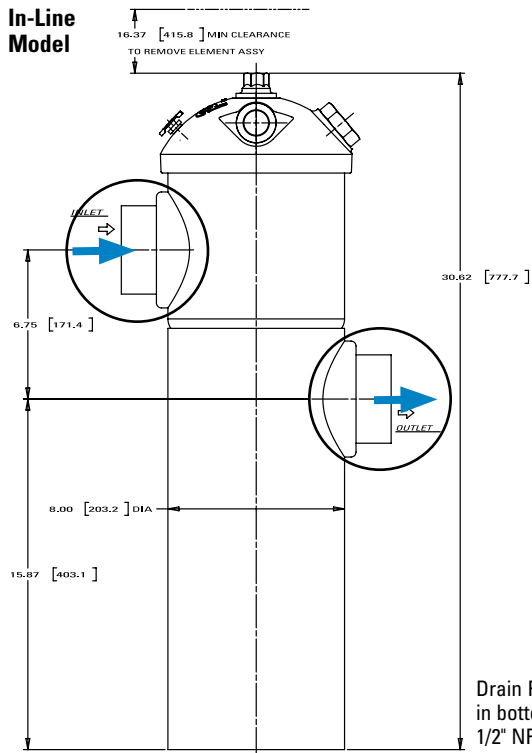

K080087 In-Line Model

Smaller port size (SAE-20) works well for kidney loop filtration.

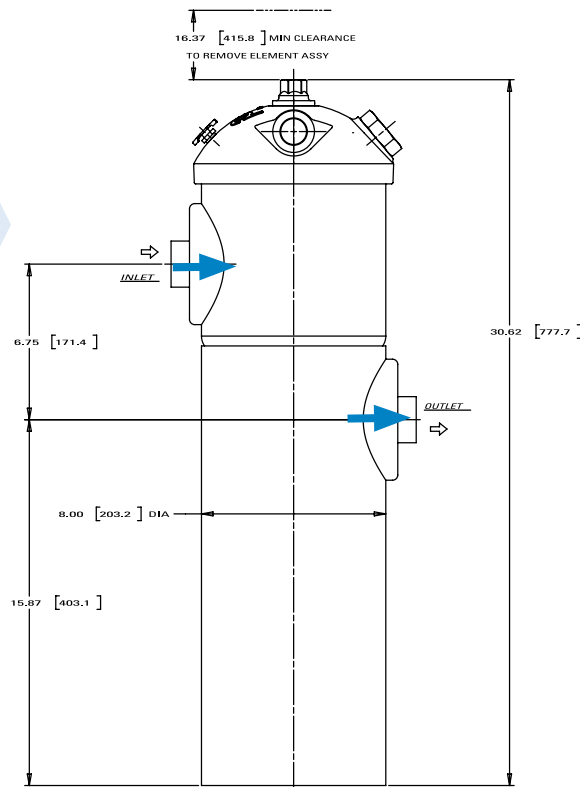

HEAD - TOP VIEWS

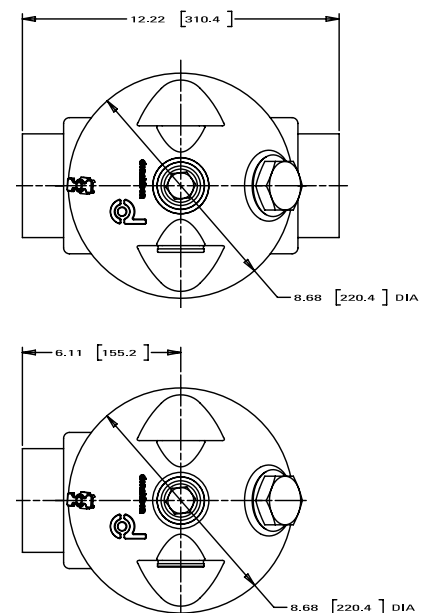



HFK08

Max Flow: 300 gpm (1135 lpm)



HFK08 Components

Filter Choices

Media Type	$\beta_{x(c)} = 2$	$\beta_{x(c)} = 1000$	Length		Part No.
	Rating based on ISO 16889		in	mm	
		<4 μm	18.00	457	P164405
		6 μm	18.00	457	P166462
		11 μm	18.00	457	P176222
		23 μm	18.00	457	P164703
Wire Mesh	45 μm		18.00	457	P173573
	150 μm		18.00	457	P163945

Filter Notes

Standard HFK08 replacement filters have nitrile seals, which are appropriate for most applications involving petroleum oil. Filters with seals made of fluorocarbon are required when using diester, phosphate ester fluids, water glycol, water/oil emulsions, and HWCF (high water content fluids) over 150°F.

HFK08 filters are inside to outside reverse flow 4.39" (112mm) OD.

Refer to the table in the Technical Reference Guide for fluid compatibility with our filter media.

Filter Assemblies

Port Size	Bypass Rating	Indicator Style' & Location	Assembly Part No.	Length (in/mm)	Filter Part No.
3" NPT	25 psi / 172.5 kPa	Visual, Left side	K080051, In-Tank	18"/457mm	P164703
		Visual, Right side	K080033, In-Line	18"/457mm	P164703
SAE-20	25 psi / 172.5 kPa	Visual, Right side	K080087, In-Line	18"/457mm	P164405

Assembly Notes

'Donaldson uses the inlet port as the reference point. "Left side," for instance, means that the indicator mounts on the side of the filter head that is on your left when you face the inlet port.



The K080087 model has features that are perfect for kidney loop filtration.

Performance Data

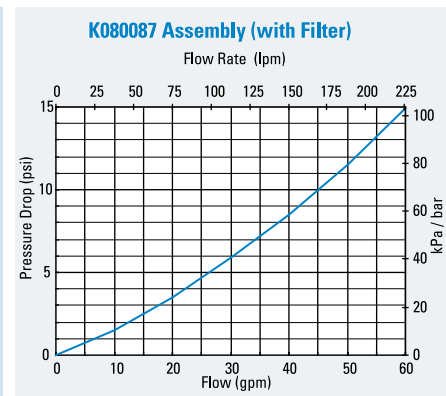
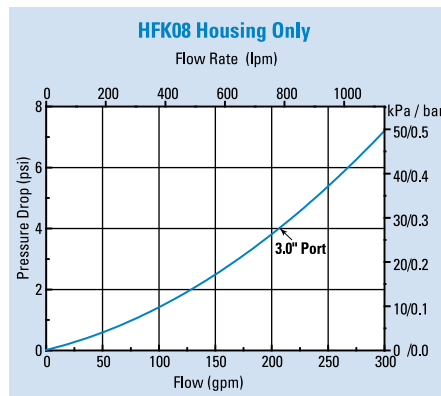
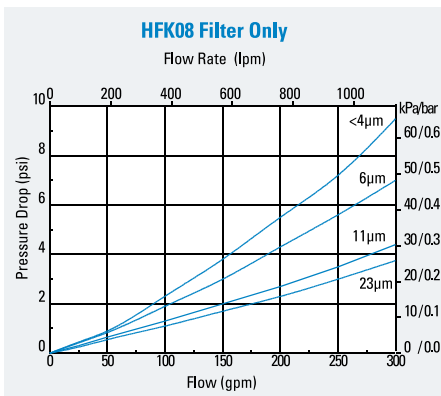

HFK08 Service Parts

SERVICE PARTS NOTE:

Some service parts may not be stocked. Please contact your Donaldson sales representative for lead time details.

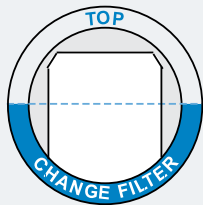
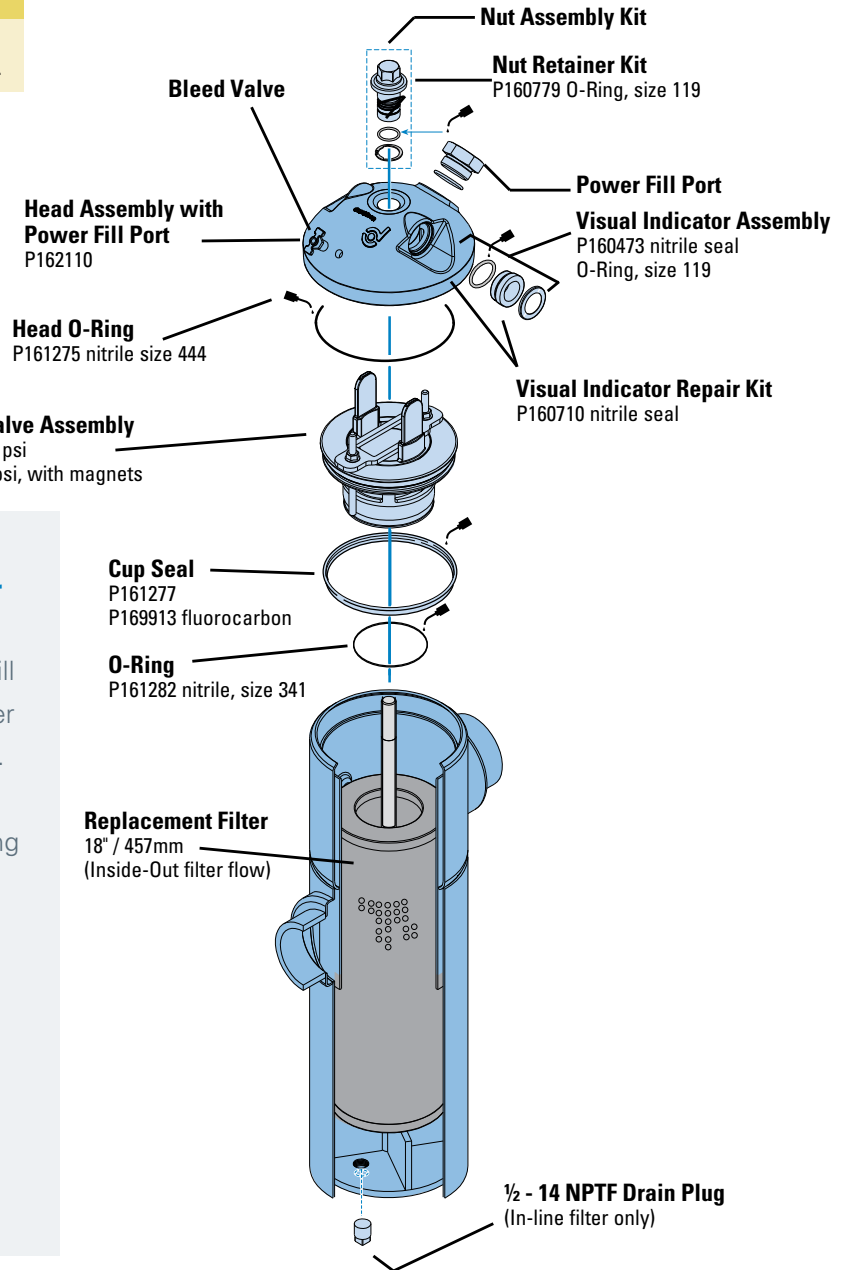

Filter OK

How to Read the Visual Indicator

This simple device will tell you when the filter needs to be changed. Always check when the fluid is at operating temperature and the system is at normal operating flow.

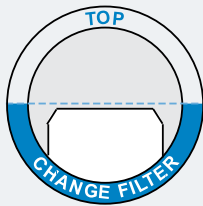

Filter Needs Service

If the top of the white panel is below the lower half of the window, the filter needs servicing.

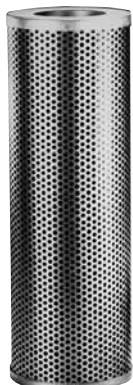

HFK08 replacement filters are available with synthetic or wire mesh media.

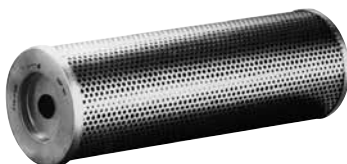

Easy.



Easier.



NOW YOU CAN SHOP FOR DONALDSON REPLACEMENT FILTERS ONLINE.

Visit shop.donaldson.com on your computer, phone or tablet to find all your top-quality aftermarket filters including fuel, lube, coolant and air intake filters for diesel engines, hydraulic and bulk tank filtration—plus exhaust system components. Distributors can now order directly with a secure login that provides access to all your account information—including past orders—so you can simply re-order with a click.

Shop.donaldson.com makes ordering replacement filters easier than easy so you can keep your business moving.

Shop for filters the easier way at
shop.donaldson.com



High Pressure Filters

High pressure filters are positioned between pumps and critical components such as cylinders, motors and valves. They help protect these critical components from catastrophic failure.

Donaldson heavy-duty high pressure filters are rated for working pressures up to 6500 psi (44818 kPa). Various porting sizes and types, including manifold style, are available for a wide range of applications.



Section Index

Max Operating Pressure < 6500 psi (450 bar)

Models arranged from low to maximum flow rates

In-line Cartridge Filters

HPK02.....	106
DPK2400.....	111
W440.....	114
FPK02.....	118
W350.....	123
HPK03.....	127
FPK04.....	132
HPK04.....	137
W451.....	143
W620.....	147
HPK05.....	152



HPK02

Max Flow: 20 gpm (76 lpm)



HPK02 In-Line Cartridge Filters

Working Pressures to:

2000 psi / 13,790 kPa / 137.9 bar

Rated Static Burst to:

4500 psi / 31,030 kPa / 310.3 bar

Flow Range To:

20 gpm / 76 lpm

Applications

- High Pressure Circuits
- In-Plant Systems
- Meets HF2 Specification
- Mobile Equipment
- Power Steering Circuits
- Servo Valve Circuits

Features

The HPK02 is a heavy-duty filter built for high pressure applications, with cast aluminum head and impact-extruded aluminum housing for strength and durability at relatively lightweight.

Take advantage of our mix and match system of in-stock heads, housings and cartridges – so you can get exactly what you need. HPK02 is available with your choice of visual or AC/DC electrical indicators. Likewise, choose the bypass option that's right for your application – 50 psi (3.5 bar) bypass, or no bypass. Seals made of fluorocarbon or nitrile are available with HPK02.

All HF2-sized HPK02 filters contain Synteq™, our synthetic filter media designed especially for hydraulic filtration.

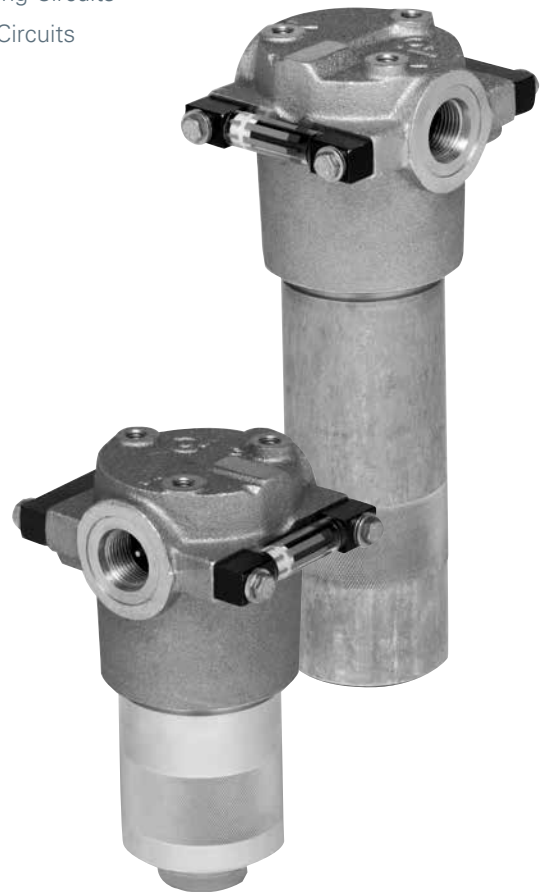

Beta Rating

- Performance to $\beta_{<40} = 1000$

Porting Size Options

- SAE-12 O-Ring

Replacement Filter Lengths

- 4.37" / 111mm
- 8.12" / 206mm

Standard Bypass Ratings

- 50 psi / 345 kPa / 3.5 bar
- No Bypass

Assembly Weight

- 4.3 lbs / 1.95 kg (short)
- 5.5 lbs / 2.49 kg (long)

Operating Temperatures

- -45° to 250°F (-43° to 121°C)

Filter Collapse Ratings

- 290 psi / 1999 kPa / 20.0 bar (standard)
- 3000 psi / 20,700 kPa / 206.9 bar (high collapse)

HPK02 Specification Illustrations

ASSEMBLY - SIDE VIEW

All dimensions are shown in inches [millimeters].

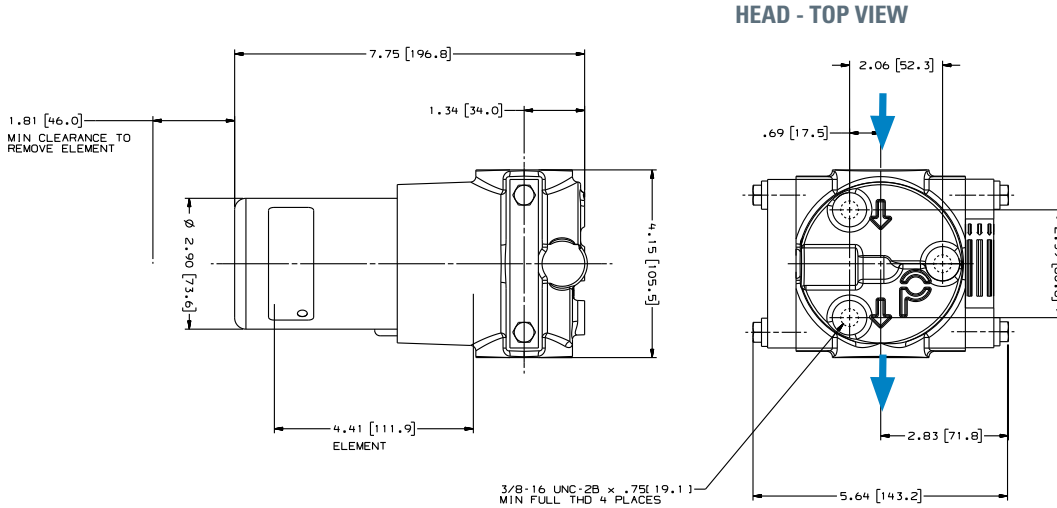

HPK02 with Visual Service Indicator

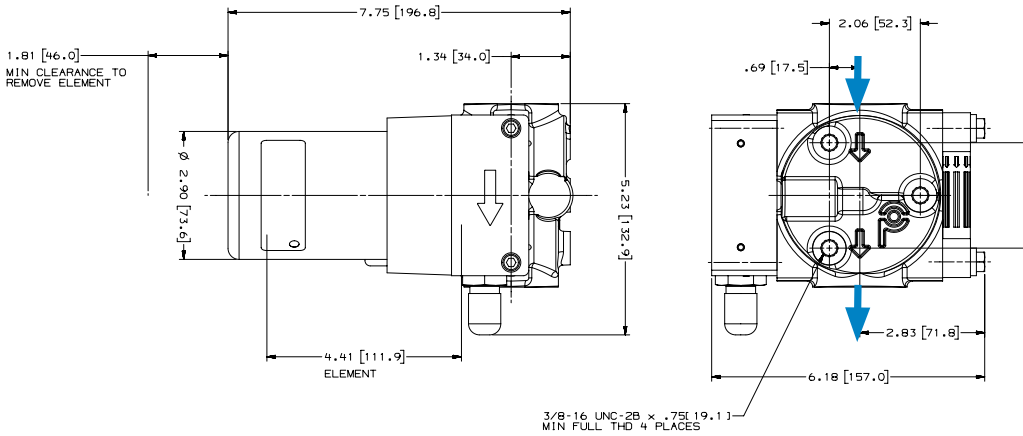

HPK02 with AC/DC Electrical Service Indicator

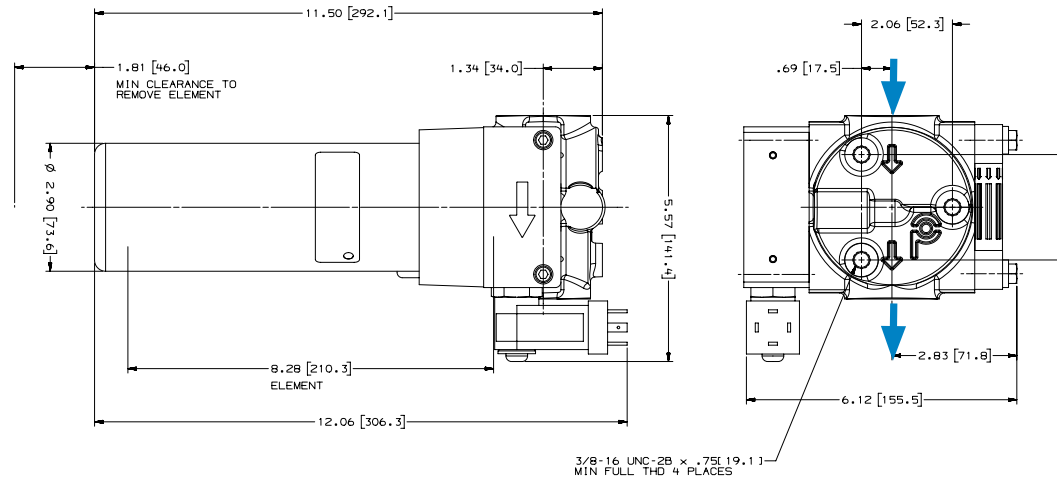



HPK02

Max Flow: 20 gpm (76 lpm)



HPK02 Components

Filter Choices

Media Type	$\beta_{x(e)} = 1000$	Length		Part No.	Comments
	Rating based on ISO 16889	in	mm		
DT Synthetic	<4 μm	4.39	112	P566194	DT-9020-4-2UM
	5 μm	4.39	112	P566195	DT-9020-4-5UM
	5 μm	4.46	113	P167180	DT-9021-4-5UM, High Collapse
	8 μm	4.39	112	P566196	DT-9020-4-8UM
	12 μm	4.39	112	P566197	DT-9020-4-14UM
	12 μm	4.46	113	P167181	DT-9021-4-14UM, High Collapse
	23 μm	4.39	112	P566198	DT-9020-4-25UM
	<4 μm	8.18	208	P566199	DT-9020-8-2UM
	5 μm	8.18	208	P566200	DT-9020-8-5UM
	5 μm	8.18	208	P167182	DT-9021-8-5UM, High Collapse
	8 μm	8.18	208	P566201	DT-9020-8-8UM
	12 μm	8.18	208	P566202	DT-9020-8-14UM
	12 μm	8.18	208	P167183	DT-9021-8-14UM, High Collapse
	23 μm	8.18	208	P566203	DT-9020-8-25UM

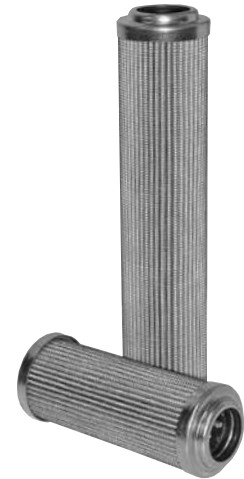

Filter Notes: All Donaldson DT filters utilize glass fiber media with an acrylic-based resin system for the ultimate in chemical compatibility. All Donaldson DT filters are potted with acrylic-based adhesives. Standard collapse DT designs are double wire-backed using acrylic-coated steel mesh for maximum pleat support and dirt capacity. Refer to the table in the Technical Reference Guide for fluid compatibility with our filter media. If filtering diester, phosphate ester fluids, water glycol, water/oil emulsions, or HWCF over 150°F/83°C, use filters with seals made of fluorocarbon. Donaldson "high collapse" filters, with their steel end caps and wire-backed media, are rated to withstand up to 3000 psi/ 20,700 kPa before collapsing. High collapse designs are also potted into machined aluminum endcaps for greater filter integrity in critical applications. The fluorocarbon seal/high collapse filters also use acrylic potting and media seam seals for added chemical compatibility. High collapse designs are double wire-backed using stainless steel mesh.

Housing Choices

Length	Part No.
Short	P167443
Long	P167452

Head Choices

Port Size	Bypass Rating	Indicators'	Part No.
SAE-12 O-Ring	50 psi/3.5 bar	Visual indicator, left side	P167728
SAE-12 O-Ring	No bypass	Visual indicator, left side	P167730

Notes on Indicators: Donaldson uses the inlet port as the reference point. "Left side," for instance, means that the indicator mounts on the side of the filter head that is on your left when you face the inlet port.

Service Indicator Kits (All kits include indicator with mounting block)

Part No.	Bypass Valve Pressure of:	Description
Visual Service Indicators		
P569632	60 psi / 4.1 bar	35 psi/2.4 bar indicator kit auto reset pop-out button
P569633	90 psi / 6.2 bar	70 psi/4.8 bar indicator kit auto reset pop-out button
P567988	60 psi / 4.1 bar	35 psi/2.4 bar indicator kit auto reset pop-out button with thermal lockout and surge control
P567989	90 psi / 6.2 bar	70 psi/4.8 bar indicator kit* auto reset pop-out button with thermal lockout and surge control
AC/DC Visual/Electrical Service Indicators		
P569634	60 psi / 4.1 bar	35 psi/2.4 bar indicator kit Hirschmann receptacle 115 VAC/28 VDC, 2 amps
P569635	90 psi / 6.2 bar	70 psi/4.8 bar indicator kit Hirschmann receptacle 115 VAC/28 VDC, 2 amps
P567986	60 psi / 4.1 bar	35 psi/2.4 bar indicator kit with thermal lockout and surge control, Hirschmann receptacle, 115 VAC/28 VDC, 2 amps, 4 pin DIN 43650
P567987	90 psi / 6.2 bar	70 psi/4.8 bar indicator kit with thermal lockout and surge control, Hirschmann receptacle, 115 VAC/28 VDC, 2 amps, 4 pin DIN 43650



Indicator Choices (Replacement Indicator Only)

Part No.	Description	Part No.	Description
P567458	Visual/Electrical indicator with thermal lockout and surge, 35 psid/2.4 bar	P569637	Pop-Up Visual Indicator, 70 psid/4.8 bar
P567459	Visual/Electrical indicator, with thermal lockout and surge, 70 psid/4.8 bar	P164315	Visual Indicator, bar style, 35 psid/2.4 bar
P567456	Pop-Up Visual Indicator, with thermal lockout and surge, 35 psid/2.4 bar	P166603	Visual Indicator, bar style, 70 psid/4.8 bar
P569636	Pop-Up Visual Indicator, 35 psid/2.4 bar	P166134	Blanking plate
Indicator Mounting Block			
P573495	Mounting Block Assembly		

Performance Data

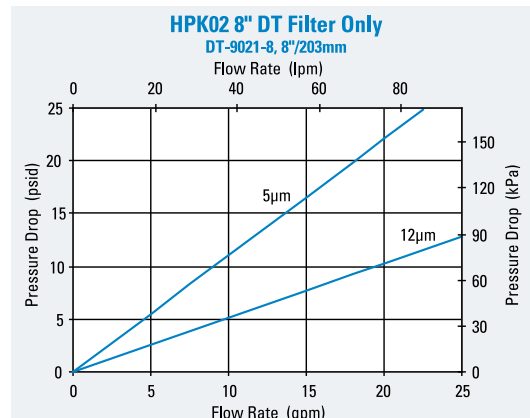
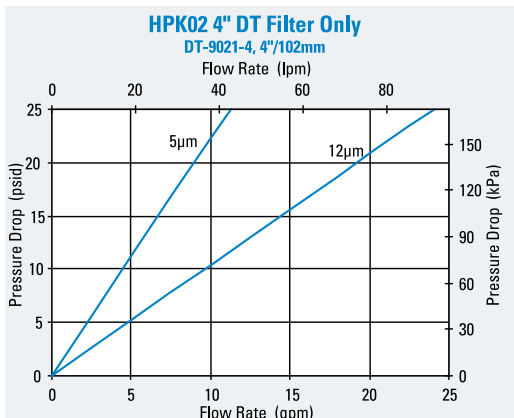
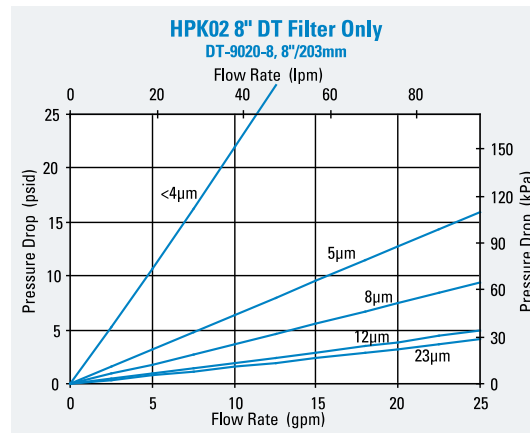
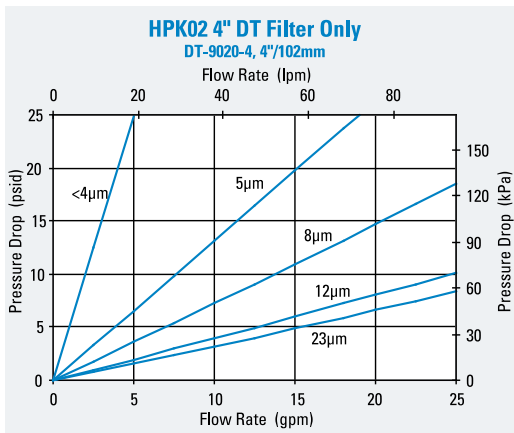
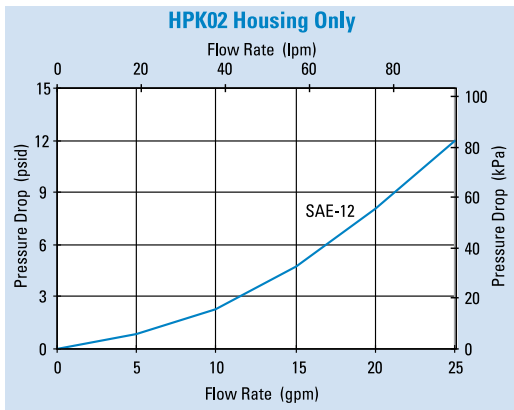



HPK02

Max Flow: 20 gpm (76 lpm)



HPK02 Service Parts

SERVICE PARTS NOTE:

Some service parts may not be stocked. Please contact your Donaldson sales representative for lead time details.

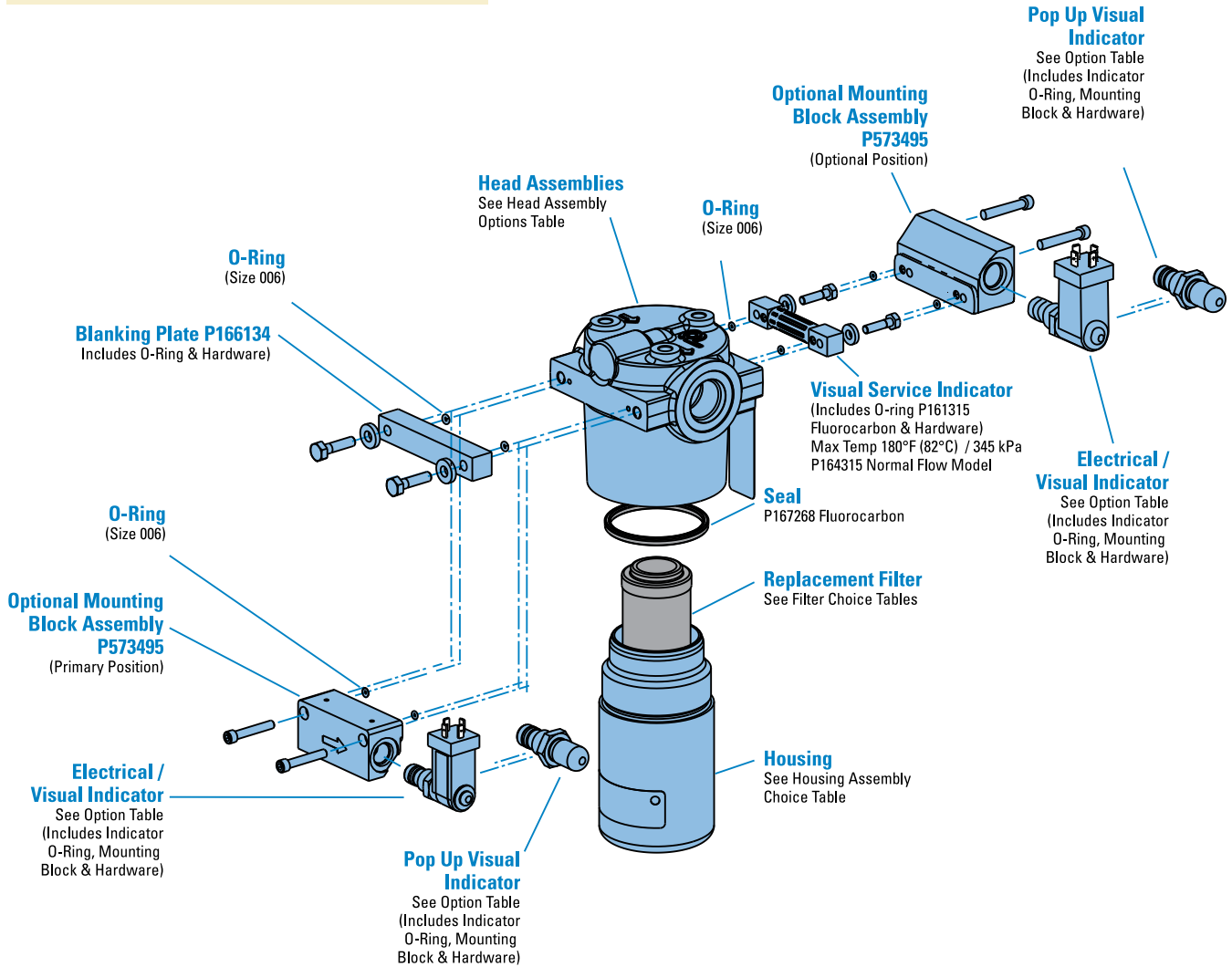

DPK2400 In-Line Cartridge Filters

Working Pressures to:

2400 psi / 16547 kPa / 165.4 bar

Rated Static Burst to:

8000 psi / 55157 kPa / 552 bar

Flow Range To:

100 gpm / 379 lpm

Applications

- In-plant Systems
- Process Fluids
- Lube Oil Systems

Features

DPK2400 duplex filter assemblies allow continuous filtration during filter servicing to avoid machine shutdown. The DPK2400 duplex design combines durable iron heads and carbon steel housings for superior, high-strength performance. Choose between optional features such as no bypass, bypass valve, visual indicators or combination electrical/visual indicators for a customized assembly that best fits the needs of your specific application. Filter performance ranges from 5 μ to 25 μ at beta 1000 and high collapse elements are available at 5 μ and 27 μ , offering additional flexibility to achieve the filtration level your system requires.

- Head Material: Durable Iron
- Housing Material: Carbon Steel
- Optional visual and visual / electric indicators
- Self locking transfer valve
- Automatic bleed-over valve



Beta Rating

- Performance to $\beta_{5(\mu)}=1000$

Porting Size Options

- 1-1/2" SAE 4-Bolt Flange Code 61

Replacement Filter Lengths

- 14.62" / 371mm

Standard Bypass Ratings

- 100 psi / 690 kPa / 6.9 bar
- No bypass

Assembly Weight

- 98 lbs / 20 kg

Operating Temperatures

- -40° to 250°F (-40° to 121°C)

Filter Collapse Ratings

- 300 psid / 207 kPa / 20.7 bar (standard)
- 3045 psid / 2100 kPa / 210 bar (high collapse)



DPK2400

Max Flow: 100 gpm (379 lpm)



DPK2400 Specification Illustrations

ASSEMBLY - SIDE VIEW

All dimensions are shown in inches [millimeters].

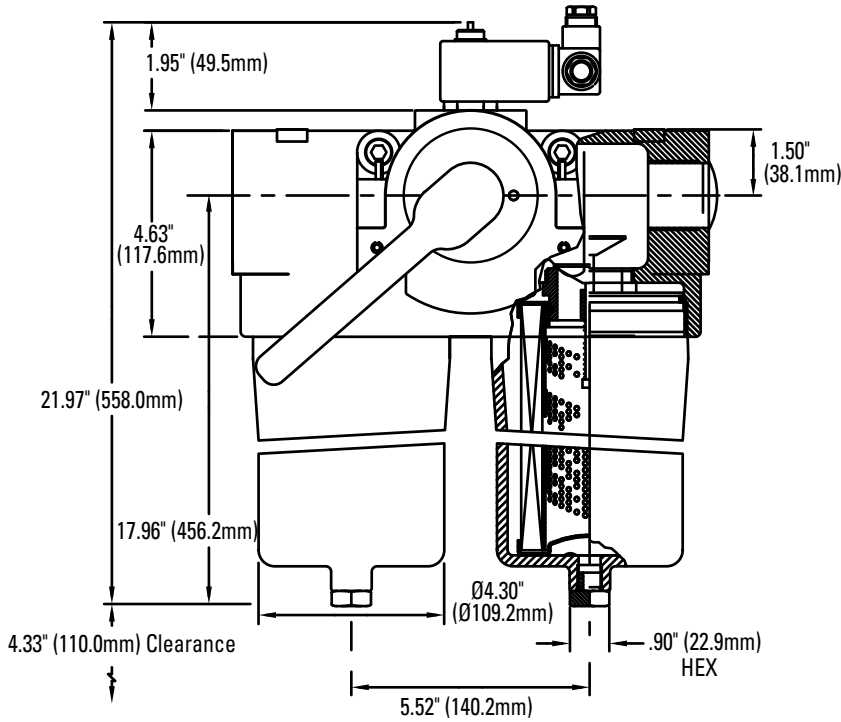

The handle shifts fluid flow from one filter to the other.

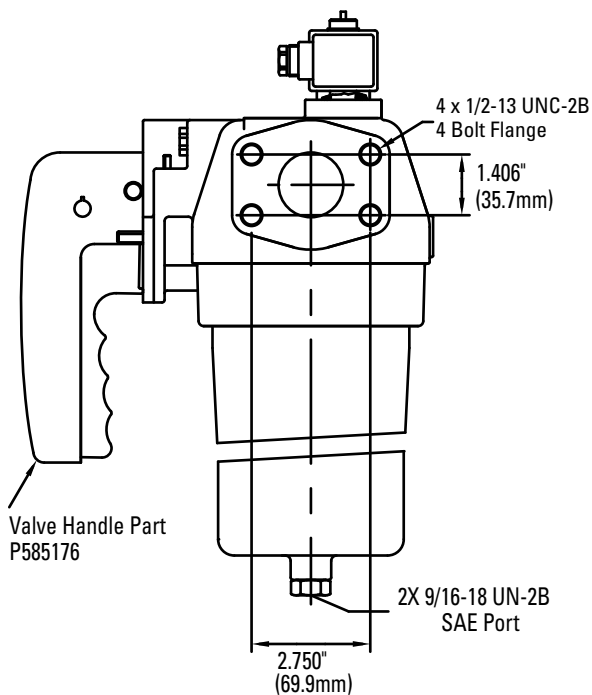
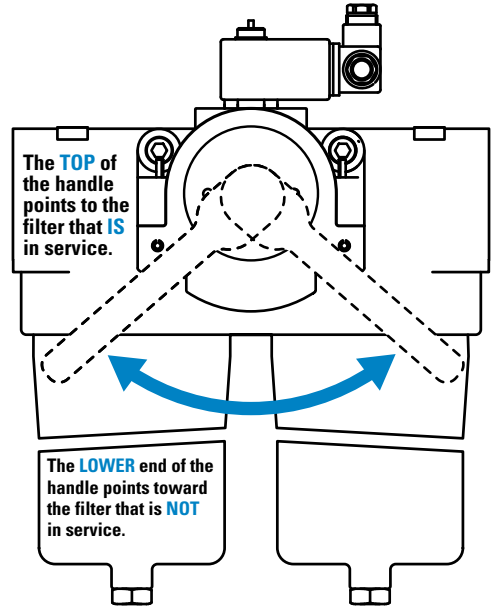

HEAD - TOP VIEW

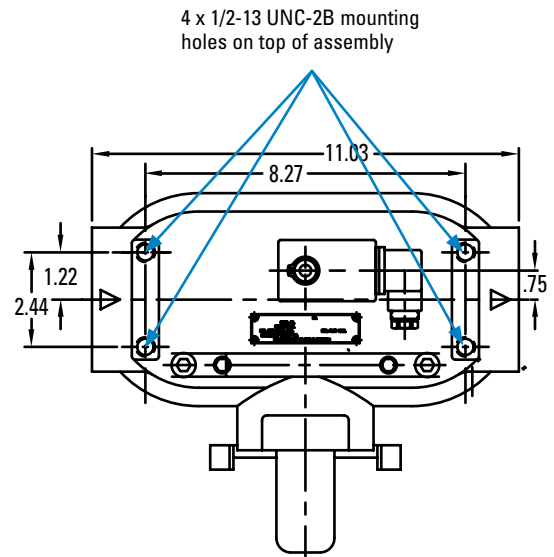

DPK2400 Components

Filter Choices

Media Type	$\beta_{x(c)} = 1000$	Length		Part No.	Comments
	Rating based on ISO 16889	in	mm		
DT Synthetic	5 μm	14.62	371	P567101	
	5 μm	14.69	373	P560716	High collapse
	8 μm	14.62	371	P567102	
	12 μm	14.62	371	P567103	
	23 μm	14.62	371	P567104	
	27 μm	14.69	373	P560718	High collapse

Assembly Choices

Part No.	Port Connections	Bypass Valve	Comments
P577026	1-1/2" SAE 4-bolt flange code 61	No bypass	Filter elements not included with assembly.
P577027	1-1/2" SAE 4-bolt flange code 61	100 psi (6.9 bar) bypass	Filter elements not included with assembly.

Service Indicator Choices

Use with Bypass Valve Pressure of:	Indicator Part No.	Seal Material	Connector Style
Visual Models			
100 psi / 690 kPa	P577030	Fluorocarbon seal	Manual reset
Visual / Electric Models			
100 psi / 690 kPa	P577031	Fluorocarbon seal	Hirschman

Performance Data

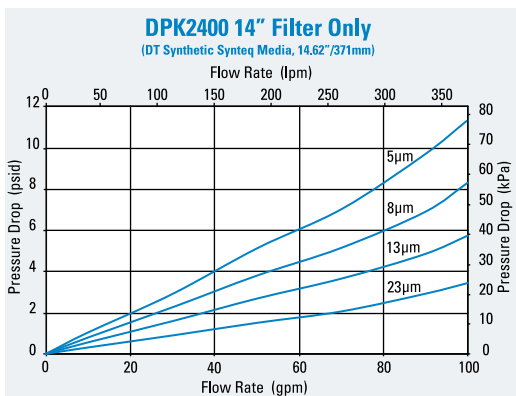
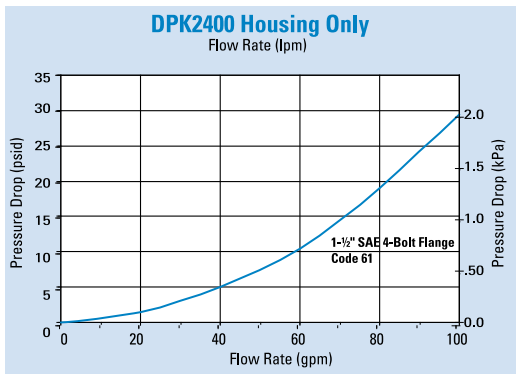

Service Part Choices

Part No.	Description
P585176	Valve Handle

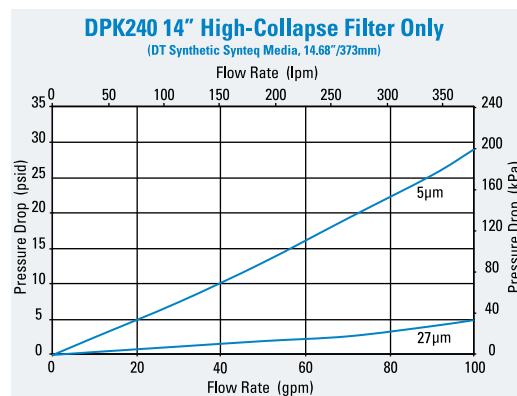



W440

Max Flow: 20 gpm (76 lpm)



W440 In-Line Cartridge Filters

Working Pressures to:

4000 psi / 27,600 kPa / 276 bar

Rated Static Burst to:

10,000 psi / 69,000 kPa / 690 bar

Flow Range To:

20 gpm / 76 lpm

Applications

- High Pressure Circuits
- In-Plant Systems
- Meets HF2 Specification
- Mobile Equipment



Features

The W440 filter assembly can be manifold mounted to the hydraulic system. The size and material configuration are well-suited for today's demanding proportional and servo valve applications. Our standard housing drain plug helps relieve system pressure during filter change-outs. DT 4-layer media is offered in a variety of designs. Five different media grades are offered. Donaldson filters core collapse options range from 150 to 3,000 psi. The differential pressure indicator line is designed to work with a wide assortment of bypass valves. Thermal lockout and surge control are two key features incorporated in many of the differential pressure indicators.

- Conforms to HF2 specifications
- High collapse filter available for use with non-bypass applications
- Positive sealing poppet bypass for reliability and zero leakage
- Wide range of indicator options
- Compact design for use with servo or proportional valve
- Two housing length options for design flexibility
- Head material: cast iron
- Housing material: steel
- Drain plug in housing

Beta Rating

- Performance to $\beta_{z(10)}=1000$

Porting Size Options

- SAE-12 O-Ring
- Manifold mounting

Replacement Filter Lengths

- 4.41" / 111.9mm
- 4.46" / 113.2mm
- 8.16" / 207.2mm
- 8.28" / 210.3mm

Standard Bypass Ratings

- 50 psi / 345 kPa / 3.5 bar
- No Bypass

Assembly Weight

- 4.41": 8.4 lbs / 3.8 kg
- 8.28": 10.6 lbs / 4.8 kg

Operating Temperatures

- -20° to 250°F (-29° to 121°C)

Filter Collapse Ratings

- 290 psi / 1999 kPa / 20.0 bar (standard)
- 3000 psi / 20,700 kPa / 206.8 bar (high collapse)

Top-ported for subplate mounting

- 0.69" (17.5mm) holes
- 1.25" (31.8mm) centers

W440 Specification Illustrations

ASSEMBLY - SIDE VIEW

All dimensions are shown in millimeters [inches].

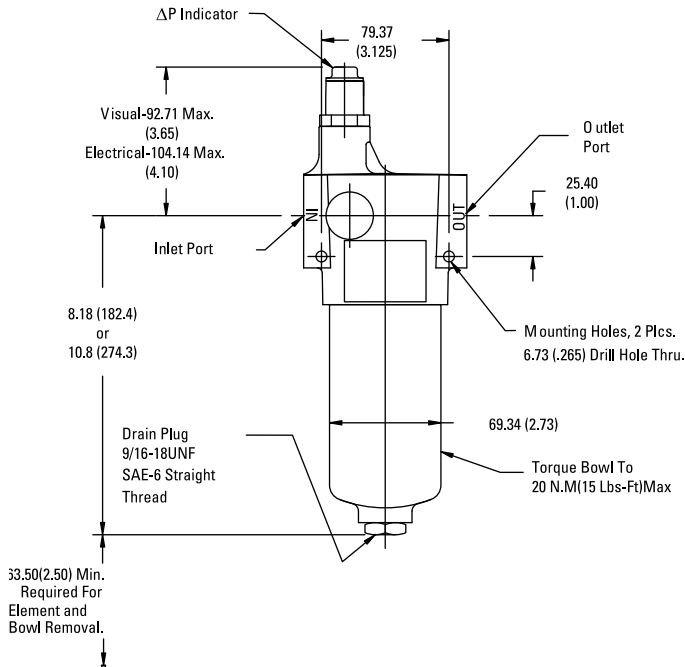

HEAD - TOP VIEW

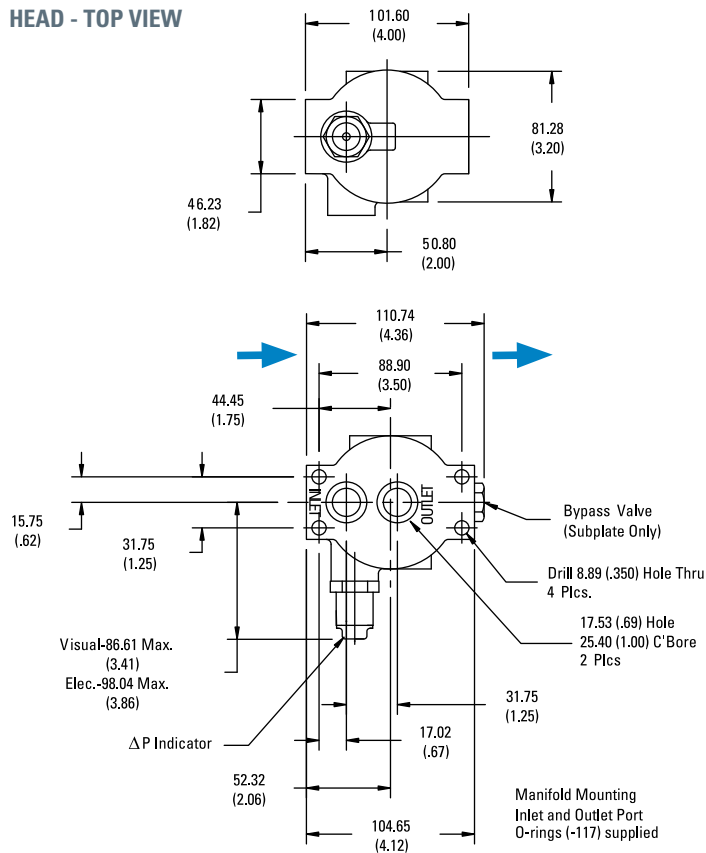



W440

Max Flow: 20 gpm (76 lpm)



W440 Components

Filter Choices

Media Type	$\beta_{x(c)} = 1000$	Length		Part No.	Comments
	Rating based on ISO 16889	in	mm		
DT Synthetic	<4 μm	4.39	112	P566194	DT-9020-4-2UM
	5 μm	4.39	112	P566195	DT-9020-4-5UM
	5 μm	4.46	113	P167180	DT-9021-4-5UM, High Collapse
	8 μm	4.39	112	P566196	DT-9020-4-8UM
	12 μm	4.39	112	P566197	DT-9020-4-14UM
	12 μm	4.46	113	P167181	DT-9021-4-14UM, High Collapse
	23 μm	4.39	112	P566198	DT-9020-4-25UM
	<4 μm	8.18	208	P566199	DT-9020-8-2UM
	5 μm	8.18	208	P566200	DT-9020-8-5UM
	5 μm	8.18	208	P167182	DT-9021-8-5UM, High Collapse
	8 μm	8.18	208	P566201	DT-9020-8-8UM
	12 μm	8.18	208	P566202	DT-9020-8-14UM
	12 μm	8.18	208	P167183	DT-9021-8-14UM, High Collapse
	23 μm	8.18	208	P566203	DT-9020-8-25UM

Filter Notes: All Donaldson DT filters utilize glass fiber media with an acrylic-based resin system for the ultimate in chemical compatibility. All Donaldson DT filters are potted with acrylic-based adhesives and are double wire-backed using acrylic-coated steel mesh for maximum pleat support and dirt capacity. Fluorocarbon seals are standard on all Donaldson DT filters. Donaldson "high collapse" filters, with their steel end caps and wire-backed media, are rated to withstand up to 3000 psi/ 20,700 kPa before collapsing. High collapse designs are also potted into machined aluminum endcaps for greater filter integrity in critical applications. The fluorocarbon seal/high collapse filters also use acrylic potting and media seam seals for added chemical compatibility. High collapse designs are double wire-backed using stainless steel mesh.

Performance Data

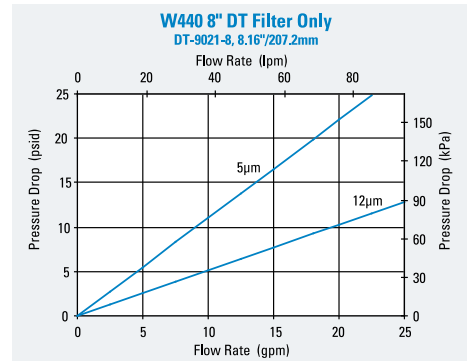
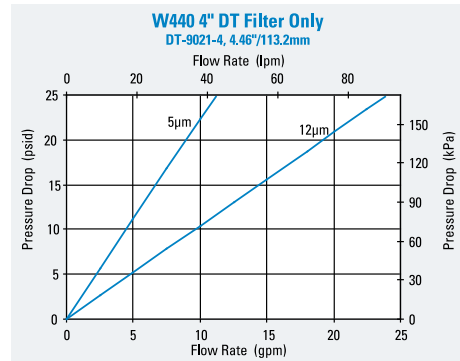
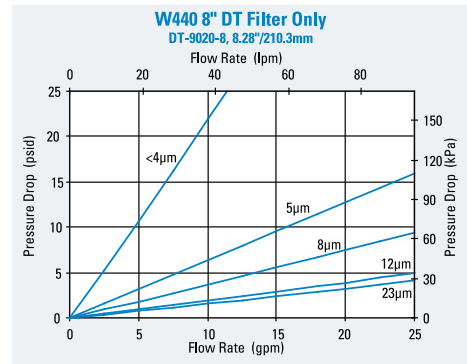
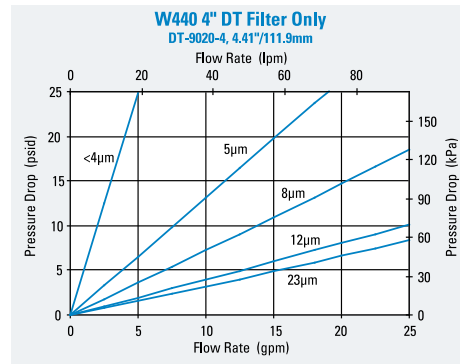
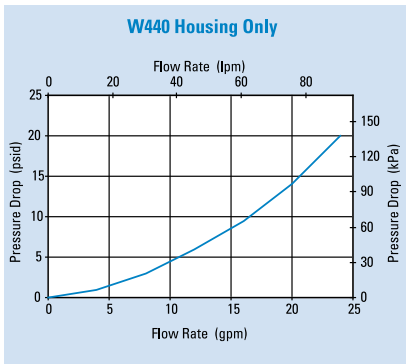

Head Assembly Choices

Port Size	Bypass Rating	Seal Material	Indicator Style & Location	Part No.
SAE-12 O-Ring	50 psi / 3.45 bar	Nitrile	Port Machined & Plugged	P574248
Manifold Mount	50 psi / 3.45 bar	Nitrile	Port Machined & Plugged	P574249
Manifold Mount	None	Fluorocarbon	Port Machined & Plugged	P574250

Housing Choices

Housing Length	Seal Material	Part No.
4" (101.6mm)	Nitrile	X011125
8" (203.2mm)	Nitrile	X011126

Service Part Choices

Part No.	Description
X011172	Head/Bowl/Housing Seal Kit - nitrile
X011173	Head/Bowl/Housing Seal Kit - fluorocarbon

Indicator Choices

Indicator Pressure Setting	Connector Style	Seal Material	Part No.	Thermal Lockout	Surge Control	Reset
Visual Pop-up Models						
35 psi / 241 kPa	NA	Nitrile	P572347	No	No	Auto
35 psi / 241 kPa	NA	Nitrile	P572348	Yes	Yes	Manual
35 psi / 241 kPa	NA	Fluorocarbon	P567456	Yes	Yes	Manual
70 psi / 482 kPa	NA	Nitrile	P572319	Yes	Yes	Manual
100 psi / 690 kPa	NA	Nitrile	P572353	Yes	Yes	Manual
100 psi / 690 kPa	NA	Fluorocarbon	P572354	Yes	Yes	Manual
Electrical / Visual Models						
35 psi / 241 kPa	Hirschman	Nitrile	P572327	No	No	Auto
35 psi / 241 kPa	Hirschman	Nitrile	P572384	Yes	Yes	Manual
35 psi / 241 kPa	Hirschman	Fluorocarbon	P567458	Yes	Yes	Manual
35 psi / 241 kPa	Brad Harrison	Nitrile	P572385	Yes	Yes	Manual
35 psi / 241 kPa	3 wire flying leads	Nitrile	P572349	No	No	Auto
70 psi / 482 kPa	Hirschman	Nitrile	P572320	Yes	Yes	Manual
70 psi / 482 kPa	Hirschman	Fluorocarbon	P567459	Yes	Yes	Manual
100 psi / 690 kPa	Hirschman	Nitrile	P572387	Yes	Yes	Manual
Electrical Models						
35 psi / 241 kPa	Hirschman	Nitrile	P572359	No	No	Auto
70 psi / 482 kPa	Hirschman	Nitrile	P572369	No	No	Auto



FPK02

Max Flow: 25 gpm (95 lpm)



FPK02 In-Line Cartridge Filters

Working Pressures to:

6090 psi / 42,021 kPa / 420 bar

Rated Static Burst to:

9135 psi / 63,000 kPa / 630 bar

Flow Range To:

25 gpm / 95 lpm

Applications

- High Pressure Circuits
- In-Plant Systems
- Meets HF2 Specification
- Mobile Equipment
- Power Steering Circuits
- Servo Valve Circuits



Features

The FPK02 is built to withstand pressures of over 6000 psi (420 bar). It features a cast iron head and cold-extruded steel housing for ultimate strength and durability. This filter meets the HF2 in-plant automotive specification. Bypass options include 87 psi/6 bar bypass, bypass with reverse-flow check valve, or no bypass.

Take advantage of our mix and match system of in-stock heads, housings and cartridges, so you can get exactly what you need. You can also choose the media type and configuration that's best for your application. All FPK02 filters contain Synteq™, Donaldson's exclusive synthetic fiber media formulated especially for hydraulic filtration.

Beta Rating

- Performance to $\beta_{240} = 1000$

Porting Size Options

- SAE-12 O-Ring

Replacement Filter Lengths

- 4.41" / 111.9mm
- 4.46" / 113.2mm
- 8.16" / 207.2mm
- 8.28" / 210.3mm

Standard Bypass Ratings

- 87 psi / 600 kPa / 6 bar
- 87 psi Bypass with reverse-flow check valve
- No Bypass

Assembly Weight

- 4.41" Assembly: 9.2 lbs / 4.2 kg
- 8.28" Assembly: 13.2 lbs / 6.0 kg

Operating Temperatures

- -20°F to 250°F / -29°C to 120°C

Filter Collapse Ratings

- 290 psi / 2000 kPa / 20 bar (standard)
- 3000 psi / 20,700 kPa / 207 bar (high collapse)

FPK02 Specification Illustrations

ASSEMBLY - SIDE VIEW

All dimensions are shown in inches [millimeters].

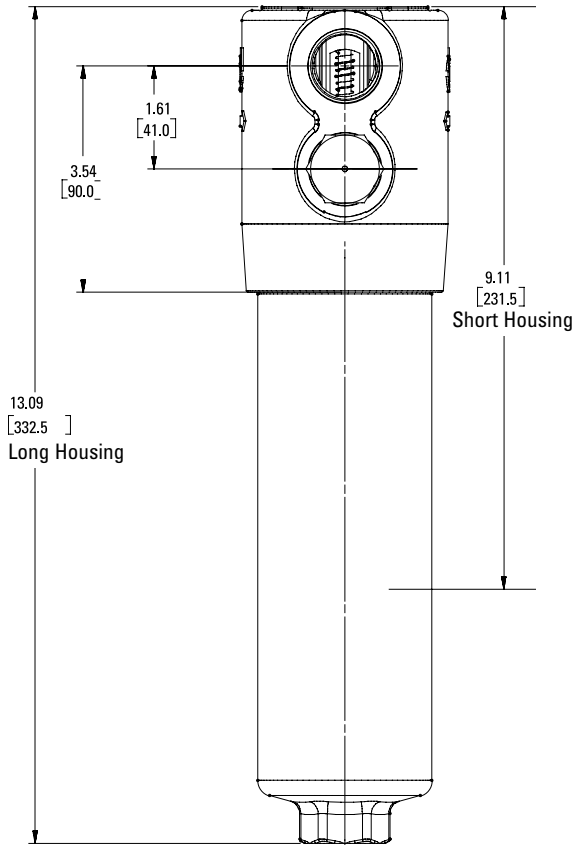

HEAD - TOP VIEW

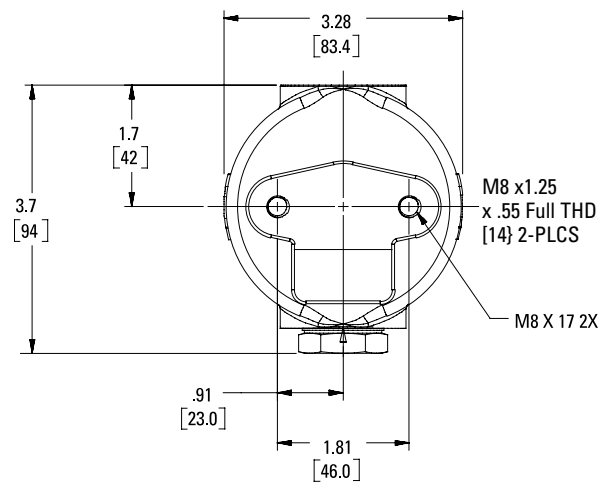

HEAD - SIDE VIEW

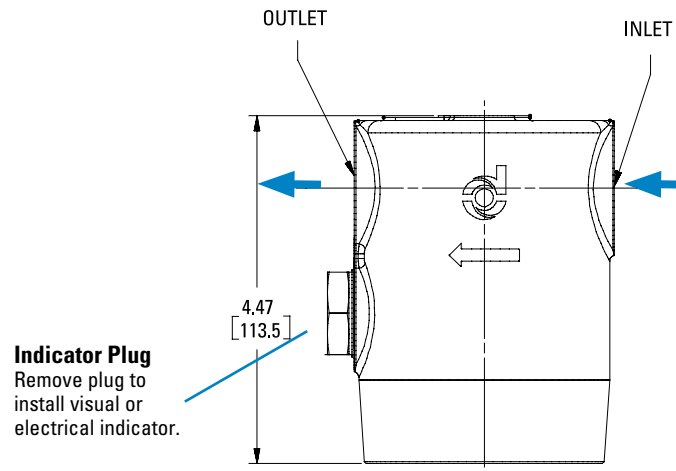



FPK02

Max Flow: 25 gpm (95 lpm)



FPK02 Components

Filter Choices

Media Type	$\beta_{x(c)} = 1000$	Length		Part No.	Comments
	Rating based on ISO 16889	in	mm		
DT Synthetic	<4 μm	4.39	112	P566194	DT-9020-4-2UM
	5 μm	4.39	112	P566195	DT-9020-4-5UM
	5 μm	4.46	113	P167180	DT-9021-4-5UM, High Collapse
	8 μm	4.39	112	P566196	DT-9020-4-8UM
	12 μm	4.39	112	P566197	DT-9020-4-14UM
	12 μm	4.46	113	P167181	DT-9021-4-14UM, High Collapse
	23 μm	4.39	112	P566198	DT-9020-4-25UM
	<4 μm	8.18	208	P566199	DT-9020-8-2UM
	5 μm	8.18	208	P566200	DT-9020-8-5UM
	5 μm	8.18	208	P167182	DT-9021-8-5UM, High Collapse
	8 μm	8.18	208	P566201	DT-9020-8-8UM
	12 μm	8.18	208	P566202	DT-9020-8-14UM
	12 μm	8.18	208	P167183	DT-9021-8-14UM, High Collapse
	23 μm	8.18	208	P566203	DT-9020-8-25UM

Filter Notes: All Donaldson DT filters utilize glass fiber media with an acrylic-based resin system for the ultimate in chemical compatibility. All Donaldson DT filters are potted with acrylic-based adhesives. Standard collapse DT designs are double wire-backed using acrylic-coated steel mesh for maximum pleat support and dirt capacity. Fluorocarbon seals are standard on all Donaldson DT filters. Refer to the table in the Technical Reference Guide for fluid compatibility with our filter media. If you're filtering diester, phosphate ester fluids, water glycol, water/oil emulsions, and HWCF over 150°F/83°C, use filters with seals made of fluorocarbon. Donaldson "high collapse" filters, with their steel end caps and wire-backed media, are rated to withstand up to 3000 psi/ 20,700 kPa before collapsing. High collapse designs are double wire-backed using stainless steel mesh and are potted into machined aluminum endcaps for greater filter integrity in critical applications. The fluorocarbon seal/high collapse filters also use acrylic potting and media seam seals for added chemical compatibility.

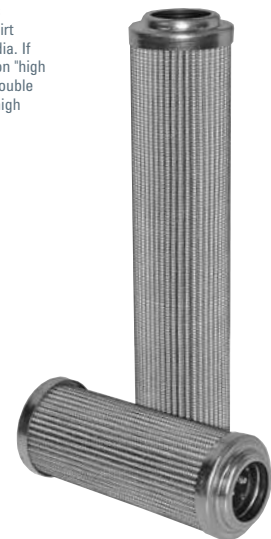

Housing Choices

Length (in)	Part No.
4.4" filter	P762769
8.2" filter	P762770

Head Choices

Port Size	Bypass Rating	Part No.
SAE-12 O-Ring	87 psi / 6 bar	P762766
SAE-12 O-Ring with reverse-flow check valve	87 psi / 6 bar	P762767
SAE-12 O-Ring	No Bypass	P762768

NOTE: Indicator port is machined and plugged. Replace plug with indicator of choice: P171945 (visual) or P761056 (electrical).

Service Part Choices

Part No.	Description
X220890	Head/Bowl/Housing seal kit - EPDM

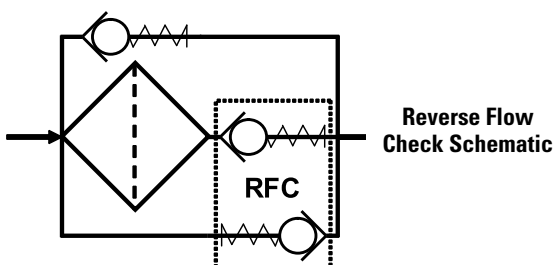

Performance Data

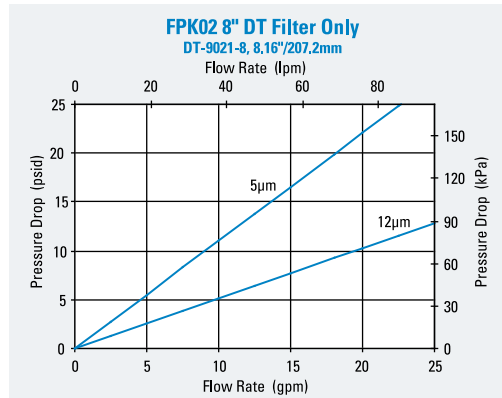
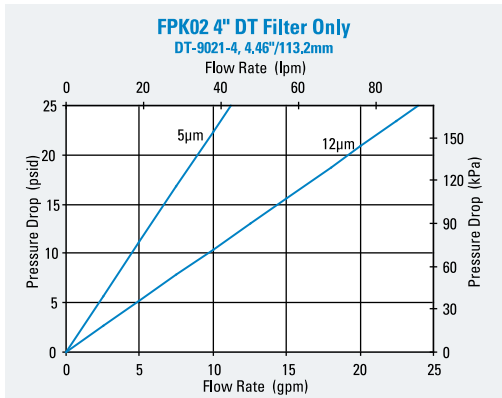
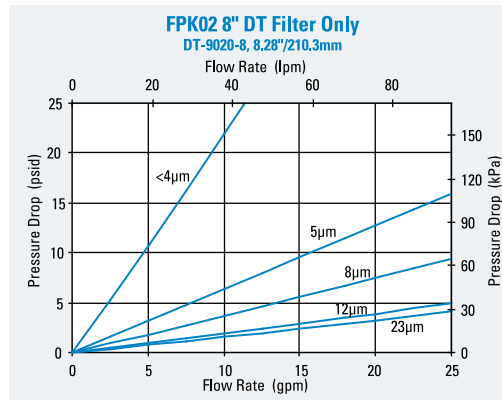
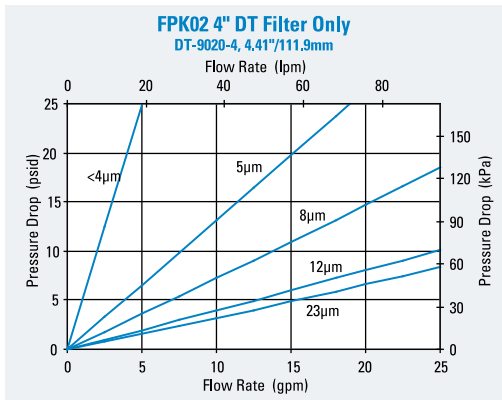
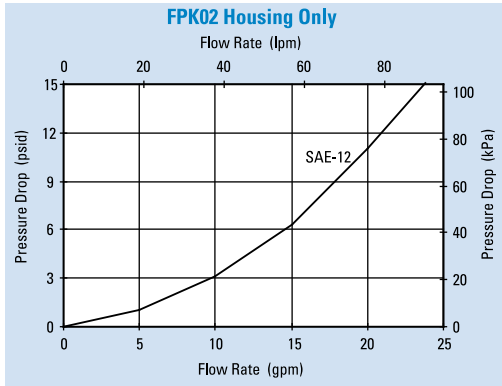



FPK02

Max Flow: 25 gpm (95 lpm)



FPK02 Service Parts

SERVICE PARTS NOTE:

Some service parts may not be stocked. Please contact your Donaldson sales representative for lead time details.

When installing the FPK02 housing onto an installed head, torque it to 15 ft-lbs./2.1 kg-m.

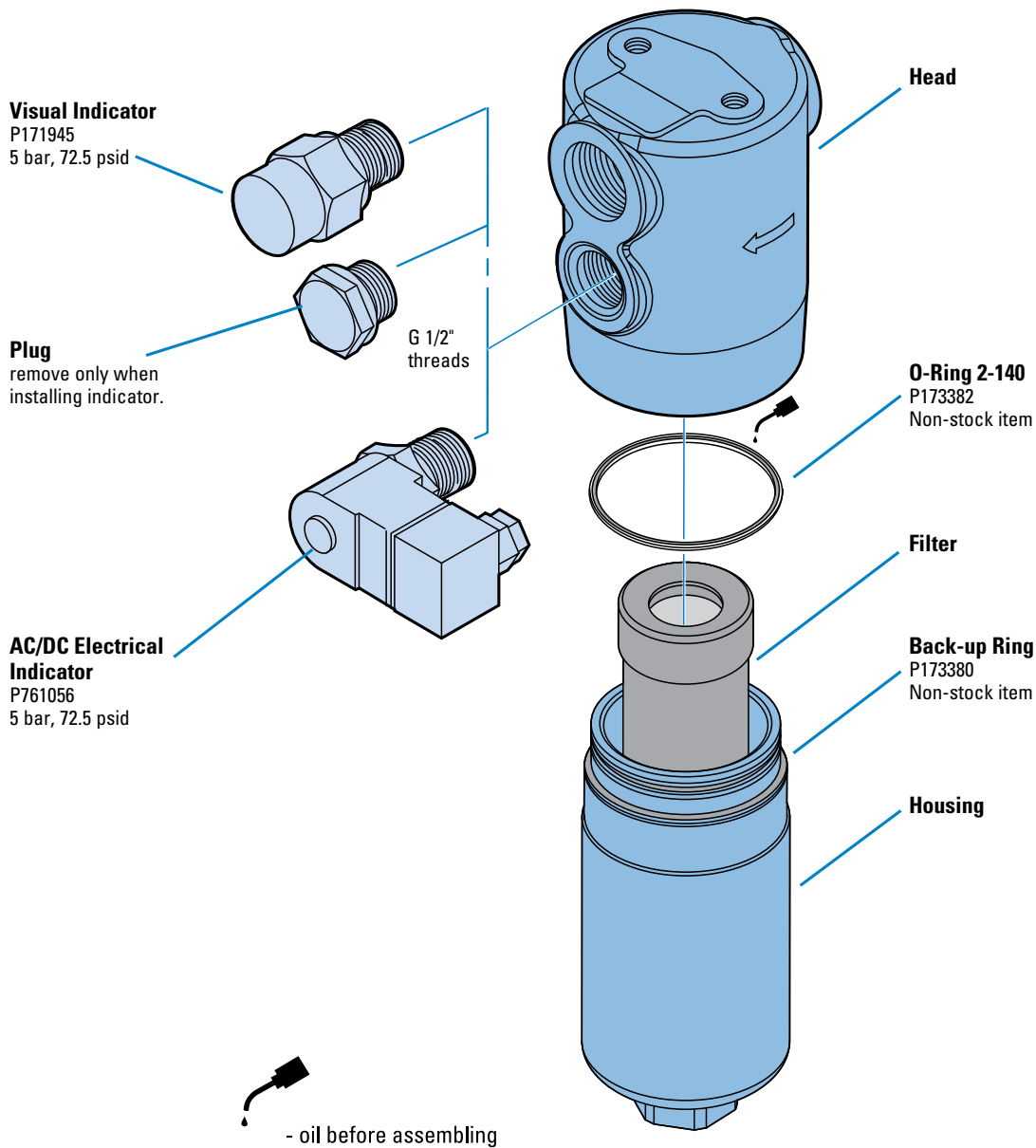

W350 In-Line Cartridge Filters

Working Pressures to:

3000 psi / 21,000 kPa / 210 bar

Rated Static Burst to:

7500 psi / 51,700 kPa / 517 bar

Fatigue Pressure Rating:

1500 psi / 10,000 kPa / 100 bar

Flow Range To:

50 gpm / 189 lpm

Applications

- High Pressure Circuits
- In-Plant Systems
- Meets HF3 Specification
- Mobile Equipment

Features

The W350 T-type ported series offers flows up to 50 gpm (190 lpm) with three bypass options and conforms to the HF3 automotive standard. Our standard housing drain plug helps relieve system pressure during filter changeouts. DT 4-layer media is offered in a variety of designs. Donaldson filters core collapse options range from 150 to 3,000 psi (10 to 210 bar). The differential pressure indicator line is designed to work with the wide assortment of bypass valves. Thermal lockout and surge control are two key features incorporated in many of the differential pressure indicators.

- Conforms to HF3 specifications
- High collapse filter available for use with non-bypass applications
- Wide range of indicator options
- Two housing length options for design flexibility
- Head material: cast iron
- Housing material: steel
- Drain plug in housing
- Bleed plug in head

Beta Rating

- Performance to $\beta_{<4(c)}=1000$

Porting Size Options

- SAE-16 O-Ring

Replacement Filter Lengths

- 4.59" / 116.7mm
- 8.22" / 208.8mm

Standard Bypass Ratings

- 25 psi / 173 kPa / 1.7 bar
- 50 psi / 345 kPa / 3.5 bar
- 90 psi / 621 kPa / 6.2 bar
- No Bypass

shop.donaldson.com

Assembly Weight

- 4.59" Assembly: 20 lbs / 9.07 kg
- 8.22" Assembly: 26 lbs / 11.79 kg

Operating Temperatures

- -20° to 250°F (-29° to 121°C)

Filter Collapse Ratings

- 290 psi / 1999 kPa / 20.0 bar (standard)
- 3000 psi / 20,700 kPa / 206.8 bar (high collapse)





W350

Max Flow: 50 gpm (189 lpm)

W350 Specification Illustrations

ASSEMBLY - SIDE VIEW

All dimensions are shown in millimeters [inches].

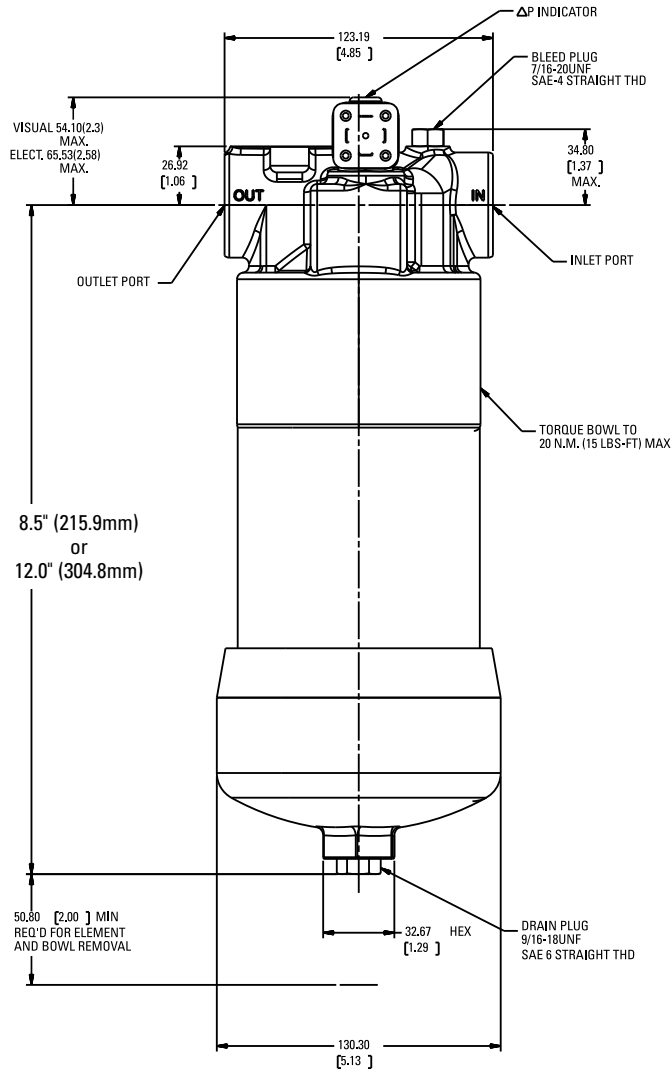

HEAD - TOP VIEW

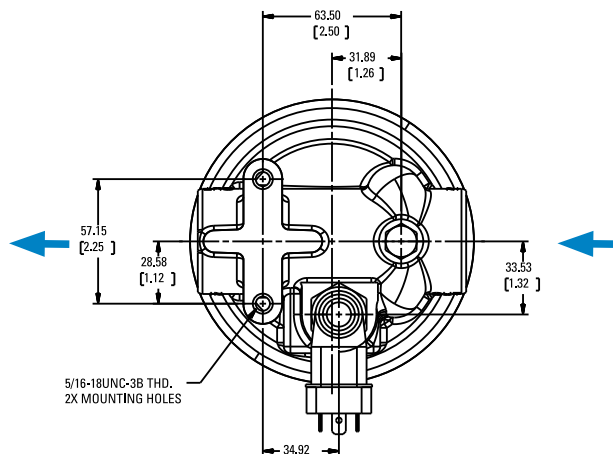

W350 Components

Filter Choices

Media Type	$\beta_{x(c)} = 2$	$\beta_{x(c)} = 1000$	Length		Part No.	Comments
	Rating based on ISO 16889		in	mm		
DT Synthetic		<4 μm	4.59	117	P566204	DT-9600-4-2UM
		5 μm	4.59	117	P566205	DT-9600-4-5UM
		5 μm	4.56	116	P167184	DT-9601-4-5UM, High collapse
		8 μm	4.59	117	P566206	DT-9600-4-8UM
		12 μm	4.59	117	P566207	DT-9600-4-14UM
		12 μm	4.56	116	P167843	DT-9601-4-14UM, High collapse
		23 μm	4.59	117	P566208	DT-9600-4-25UM
		<4 μm	8.22	209	P566209	DT-9600-8-2UM
		5 μm	8.22	209	P566210	DT-9600-8-5UM
		5 μm	8.19	208	P167185	DT-9601-8-5UM, High collapse
		8 μm	8.22	209	P566211	DT-9600-8-8UM
		12 μm	8.22	209	P566212	DT-9600-8-14UM
		12 μm	8.19	208	P167186	DT-9601-8-14UM, High collapse
	23 μm	8.22	209	P566213	DT-9600-8-25UM	
Water Absorbing	10 μm		8	209	P569528	Absorbs 130 ml water @ 25 psid



Filter Notes: All Donaldson DT filters utilize glass fiber media with an acrylic-based resin system for the ultimate in chemical compatibility. All Donaldson DT filters are potted with acrylic-based adhesives. Standard collapse DT designs are double wire-backed using acrylic-coated steel mesh for maximum pleat support and dirt capacity. High collapse designs are double wire-backed using stainless steel mesh. High collapse designs are also potted into machined aluminum endcaps for greater filter integrity in critical applications. Fluorocarbon seals are standard on all Donaldson DT filters.

Performance Data

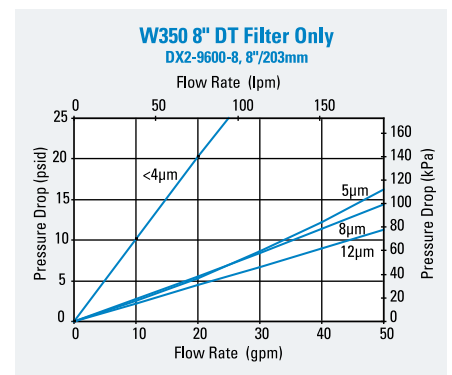
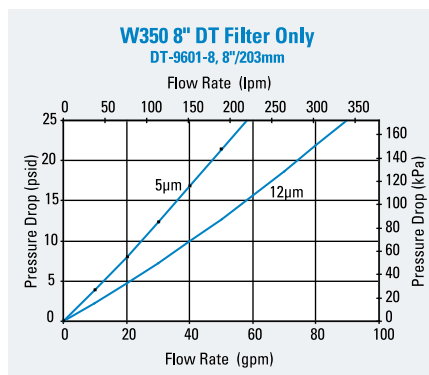
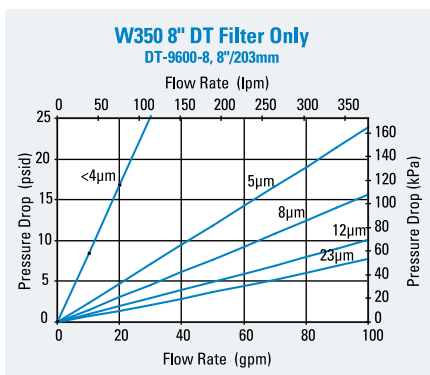
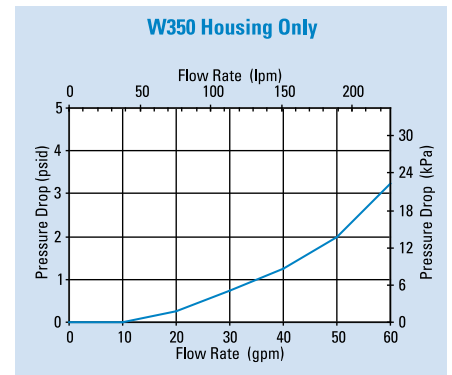
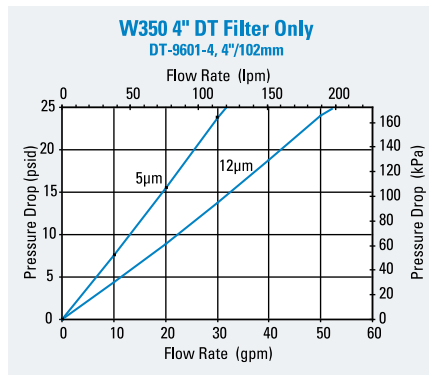
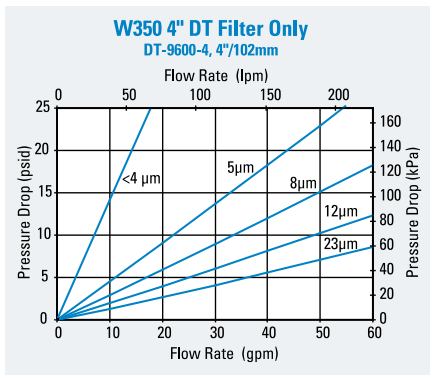



W350

Max Flow: 50 gpm (189 lpm)



Head Assembly Choices

Port Size	Bypass Rating	Seal Material	Indicator Style & Location	Part No.
SAE-16 O-Ring	50 psi / 3.45 bar	Nitrile	Port Machined & Plugged	P574245
SAE-16 O-Ring	90 psi / 6.21 bar	Nitrile	Port Machined & Plugged	P574246
SAE-16 O-Ring	None	Nitrile	Port Machined & Plugged	P574247

Housing Choices

Housing Length	Seal Material	Part No.
4" (101.6mm)	Nitrile	X011556
8" (203.2mm)	Nitrile	X011558

Service Part Choices

Part No.	Description
X011170	Head/Bowl/Housing Seal Kit - nitrile
X011171	Head/Bowl/Housing Seal Kit - fluorocarbon

Indicator Choices

Indicator Pressure Setting	Connector Style	Seal Material	Part No.	Thermal Lockout	Surge Control	Reset
Visual Pop-up Models						
35 psi / 241 kPa	NA	Nitrile	P572347	No	No	Auto
35 psi / 241 kPa	NA	Nitrile	P572348	Yes	Yes	Manual
35 psi / 241 kPa	NA	Fluorocarbon	P567456	Yes	Yes	Manual
70 psi / 482 kPa	NA	Nitrile	P572319	Yes	Yes	Manual
100 psi / 690 kPa	NA	Nitrile	P572353	Yes	Yes	Manual
100 psi / 690 kPa	NA	Fluorocarbon	P572354	Yes	Yes	Manual
Electrical / Visual Models						
35 psi / 241 kPa	Hirschman	Nitrile	P572327	No	No	Auto
35 psi / 241 kPa	Hirschman	Nitrile	P572384	Yes	Yes	Manual
35 psi / 241 kPa	Hirschman	Fluorocarbon	P567458	Yes	Yes	Manual
35 psi / 241 kPa	Brad Harrison	Nitrile	P572385	Yes	Yes	Manual
35 psi / 241 kPa	3 wire flying leads	Nitrile	P572349	No	No	Auto
70 psi / 482 kPa	Hirschman	Nitrile	P572320	Yes	Yes	Manual
70 psi / 482 kPa	Hirschman	Fluorocarbon	P567459	Yes	Yes	Manual
100 psi / 690 kPa	Hirschman	Nitrile	P572387	Yes	Yes	Manual
Electrical Models						
35 psi / 241 kPa	Hirschman	Nitrile	P572359	No	No	Auto
70 psi / 482 kPa	Hirschman	Nitrile	P572369	No	No	Auto

HPK03 In-Line Cartridge Filters

Working Pressures to:

3000 psi / 20,700 kPa / 206.9 bar

Rated Static Burst to:

6000 psi / 41,400 kPa / 413.8 bar

Flow Range To:

60 gpm / 227 lpm

Applications

- High Pressure Circuits
- In-Plant Systems
- Meets HF3 Specification
- Mobile Equipment
- Servo Valve Circuits

Features

The sturdy HPK03 filter is constructed of ductile iron for durability in high pressure applications. Standard housing drain plug means simplified servicing. Housing includes a fluoroelastomer head-to-housing seal. Meets HF3 specification.

Take advantage of our mix and match system of in-stock heads and cartridges—so you can get exactly what you need. HPK03 is available with your choice of visual or AC/DC electrical indicators. Likewise, choose the bypass option that's right for your application—50 psi (3.5 bar) or no bypass. Seals made of fluorocarbon or nitrile are available with HPK03.

All HPK03 filters contain Synteq[®], our synthetic filter media designed especially for hydraulic filtration. Upgraded Donaldson DT filters are also offered for superior performance.



Beta Rating

- Performance to $\beta_{<4(\mu)}=1000$

Porting Size Options

- SAE-12, SAE-16 O-Ring

Replacement Filter Lengths

- 8.22" / 208.8mm

Standard Bypass Ratings

- 50 psi / 345 kPa / 3.5 bar
- No Bypass

Assembly Weight

- 26 lbs / 11.8 kg

Operating Temperatures

- -20°F to 250°F / -29°C to 121°C

Filter Collapse Ratings

- 200 psi / 1380 kPa / 13.8 bar (standard)
- 3000 psi / 20,700 kPa / 206.9 bar (high collapse)



HPK03

Max Flow: 60 gpm (227 lpm)



HPK03 Specification Illustrations

ASSEMBLY - SIDE VIEW

HEAD - TOP VIEW

All dimensions are shown in inches [millimeters].

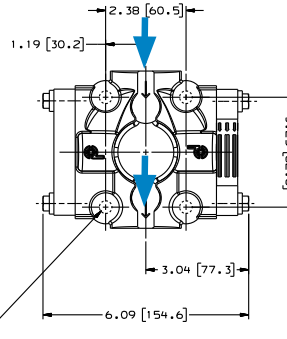
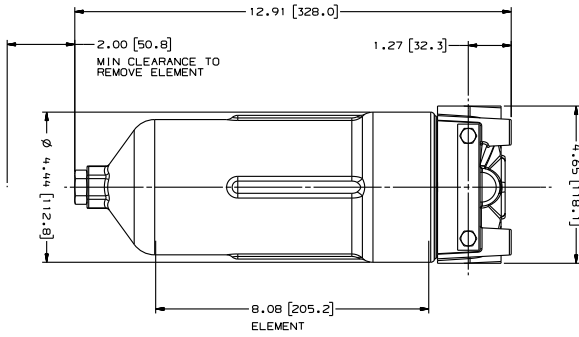

HPK03 with Visual Service Indicator

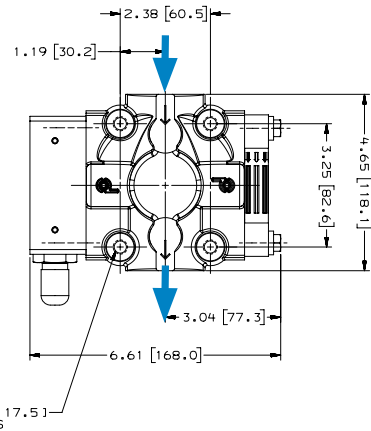
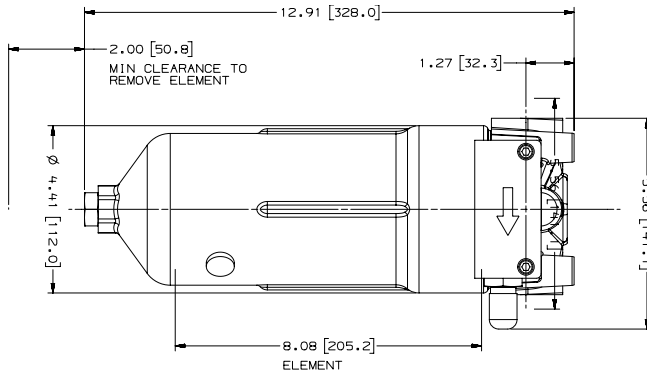

HPK03 with AC/DC Electrical Service Indicator

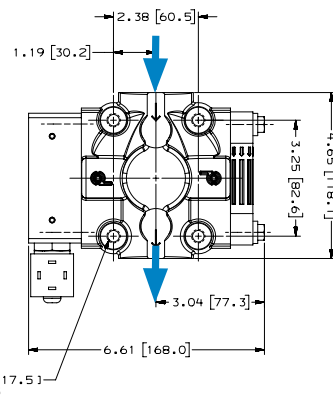
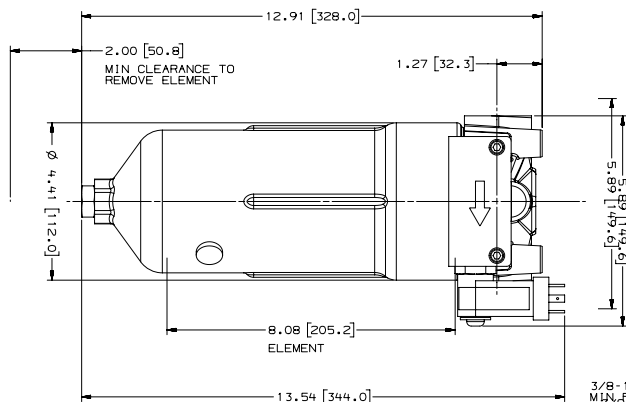

HPK03 Components

Filter Choices

Media Type	$\beta_{x(c)} = 1000$	$\beta_{x(c)} = 2$	Length		Part No.	Comments
	Rating based on ISO 16889		in	mm		
DT Synthetic	<4 μm		8.22	209	P566209	DT-9600-8-2UM
	5 μm		8.22	209	P566210	DT-9600-8-5UM
	5 μm		8.22	209	P167185	DT-9601-8-5UM, High Collapse
	8 μm		8.22	209	P566211	DT-9600-8-8UM
	12 μm		8.22	209	P566212	DT-9600-8-14UM
	12 μm		8.22	209	P167186	DT-9601-8-14UM, High Collapse
	23 μm		8.22	209	P566213	DT-9600-8-25UM
Water Absorbing		10 μm	8.22	209	P569528	
Wire Mesh		75 μm	8.22	209	P162233	

Filter Notes: All Donaldson DT filters utilize glass fiber media with an acrylic-based resin system for the ultimate in chemical compatibility. All Donaldson DT filters are potted with acrylic-based adhesives. Standard collapse DT designs are double wire-backed using acrylic-coated steel mesh for maximum pleat support and dirt capacity. Fluorocarbon seals are standard on all Donaldson DT filters. Refer to the table in the Technical Reference Guide for fluid compatibility with our filter media. If filtering diester, phosphate ester fluids, water glycol, water/oil emulsions, or HWCF over 150°F/83°C, use filters with seals made of fluorocarbon. Donaldson "high collapse" filters, with their steel end caps and wire-backed media, are rated to withstand up to 3000 psi/ 20,700 kPa before collapsing. High collapse designs are also potted into machined aluminum endcaps for greater filter integrity in critical applications. The fluorocarbon seal/high collapse filters also use acrylic potting and media seam seals for added chemical compatibility.



Housing Choices

Length	Part No.
8.22" (208.8mm) filter	P179579

The **P179579** housing is 10.73 inches (273mm) long and accepts the filter that is 8.22 inches (208.8mm) long. It includes a head-to-housing seal.

Head Choices

Port Size	Bypass Rating	Indicators ¹	Part No.
SAE-16 O-Ring	50 psi / 3.5 bar	Visual indicator, left side	P166353
SAE-12 O-Ring	50 psi / 3.5 bar	Visual indicator, left side	P170489
SAE-12 O-Ring	No bypass	Visual indicator, left side	P170491

Notes
¹Donaldson uses the inlet port as the reference point. "Left side," for instance, means that the indicator mounts on the side of the filter head that is on your left when you face the inlet port.



HPK03

Max Flow: 60 gpm (227 lpm)



Service Indicator Kits (All kits include indicator with mounting block)

Part No.	Bypass Valve Pressure of:	Description
Visual Service Indicators		
P569632	50 psi / 3.5 bar	35 psi/2.4 bar indicator kit auto reset pop-out button
P569633	90 psi / 6.2 bar	70 psi/4.8 bar indicator kit auto reset pop-out button
P567988	50 psi / 3.5 bar	35 psi/2.4 bar indicator kit auto reset pop-out button with thermal lockout and surge control
P567989	90 psi / 6.2 bar	70 psi/4.8 bar indicator kit* auto reset pop-out button with thermal lockout and surge control
AC/DC Visual/Electrical Service Indicators		
P569634	50 psi / 3.5 bar	35 psi/2.4 bar indicator kit Hirschmann receptacle 115 VAC/28 VDC, 2 amps
P569635	90 psi / 6.2 bar	70 psi/4.8 bar indicator kit Hirschmann receptacle 115 VAC/28 VDC, 2 amps
P567986	50 psi / 3.5 bar	35 psi/2.4 bar indicator kit with thermal lockout and surge control, Hirschmann receptacle, 115 VAC/28 VDC, 2 amps, 4 pin DIN 43650
P567987	90 psi / 6.2 bar	70 psi/4.8 bar indicator kit with thermal lockout and surge control, Hirschmann receptacle, 115 VAC/28 VDC, 2 amps, 4 pin DIN 43650

Indicator Choices

Part No.	Description	Part No.	Description
Replacement Indicator Only			
P567458	Visual/Electrical indicator with thermal lockout and surge, 35 psid/2.4 bar	P569637	Pop-Up Visual Indicator, 70 psid/4.8 bar
P567459	Visual/Electrical indicator, with thermal lockout and surge 70 psid/4.8 bar	P164315	Visual Indicator, bar style, 35 psid/2.4 bar
P567456	Pop-Up Visual Indicator, with thermal lockout and surge 35 psid/2.4 bar	P166603	Visual Indicator, bar style, 70 psid/4.8 bar
P569636	Pop-Up Visual Indicator, 35 psid/2.4 bar	P166134	Blanking plate
Indicator Mounting Block			
P573495	Mounting Block Assembly		

Performance Data

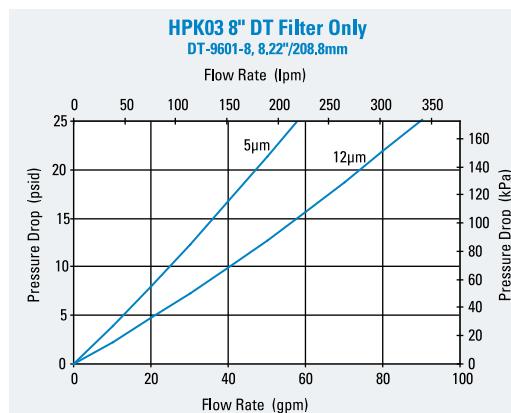
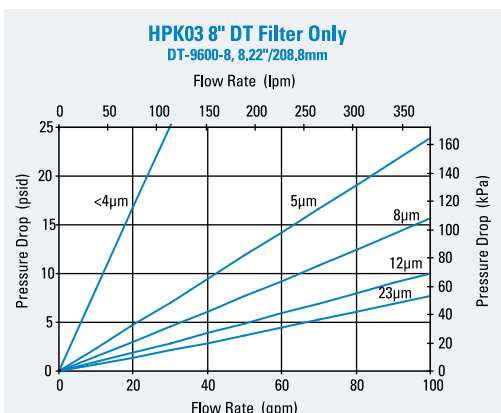
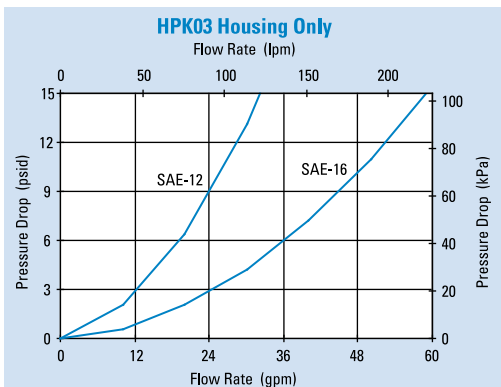

HPK03 Service Parts

SERVICE PARTS NOTE:

Some service parts may not be stocked. Please contact your Donaldson sales representative for lead time details.

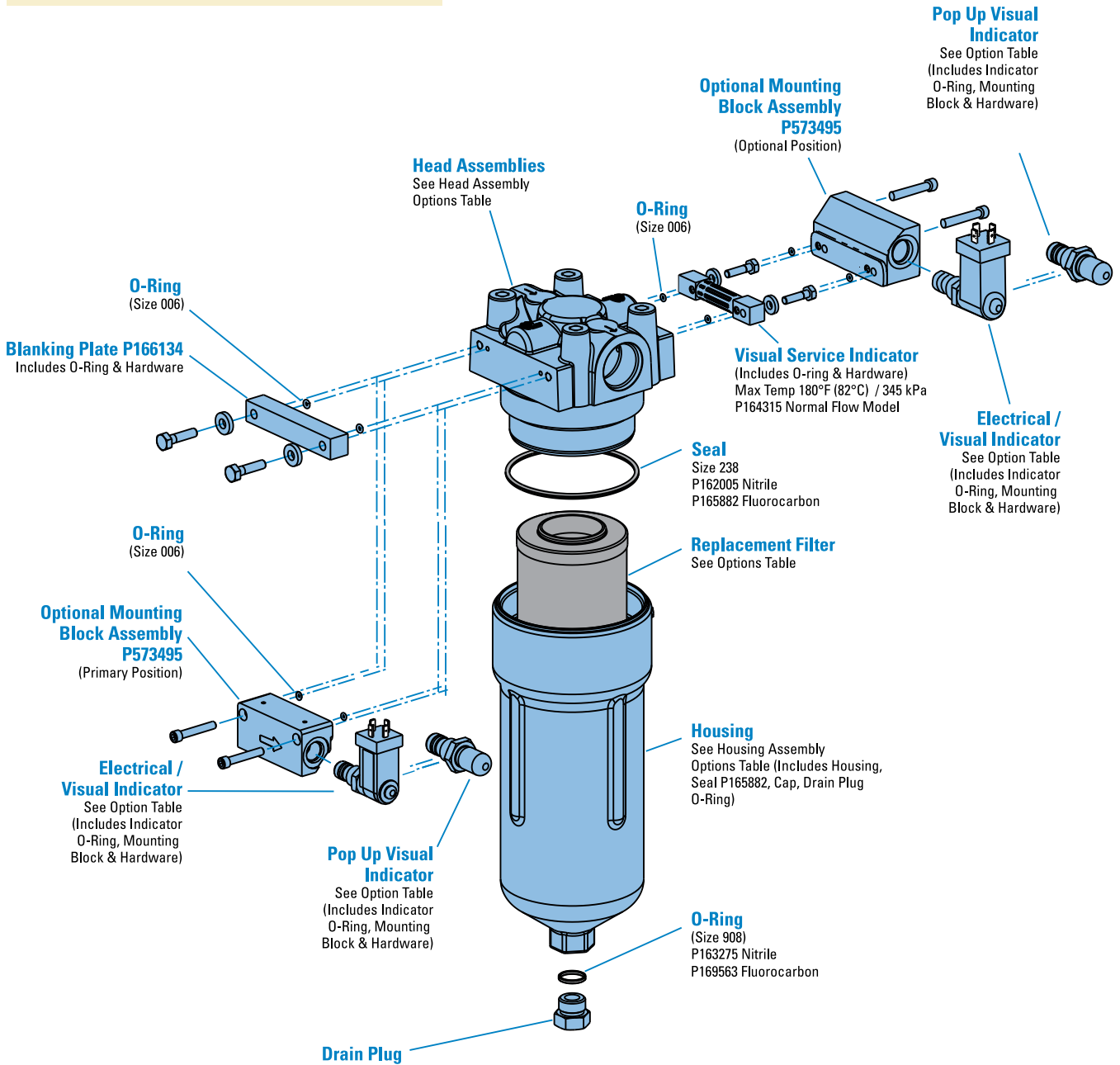



FPK04

Max Flow: 100 gpm (379 lpm)



FPK04 In-Line Cartridge Filters

Working Pressures to:

4350 psi / 30,015 kPa / 300 bar

Rated Static Burst to:

9135 psi / 63,000 kPa / 630 bar

Flow Range To:

100 gpm / 379 lpm

Applications

- High Pressure Circuits
- In-Plant Systems
- Meets HF3 Specification
- Mobile Equipment
- Servo Valve Circuits



Features

The FPK04 T-type ported series offers flows up to 100 gpm (379 lpm) with a bypass option and conforms to the HF3 automotive standard. Donaldson Synteq™ media is offered in a variety of designs. Upgraded Donaldson high-performance DT filters are also offered for superior performance. The differential pressure indicator line is designed to work with the wide assortment of bypass valve options.

- Conforms to HF3 specifications
- High collapse filters available for use with non-bypass applications
- Wide range of indicator options
- Three housing length options for design flexibility
- Nitrile seals standard, fluorocarbon available
- Head material: cast iron
- Housing material: steel

Beta Rating

- Performance to $\beta_{z(4)}=1000$

Porting Size Options

- SAE-20 O-Ring

Replacement Filter Lengths

- 4.56" / 116mm
- 4.59" / 117mm
- 8.19" / 208mm
- 8.22" / 209mm
- 8.23" / 209mm
- 12.85" / 326mm
- 12.87" / 327mm
- 12.91" / 328mm

Standard Bypass Ratings

- 87 psi / 600 kPa / 6.0 bar
- No Bypass

Assembly Weight

- 4.59": 26.4 lbs / 12.0 kg
- 8.22": 33 lbs / 15.0 kg
- 12.91": 33 lbs / 15.0 kg

Operating Temperatures

- -4° to 248°F (-20° to 120°C)

Filter Collapse Ratings

- 290 psi / 1999 kPa / 20.0 bar (standard)
- 3000 psi / 20,700 kPa / 206.8 bar (wire mesh)

FPK04 Specification Illustrations

ASSEMBLY - SIDE VIEW

All dimensions are shown in inches [millimeters].

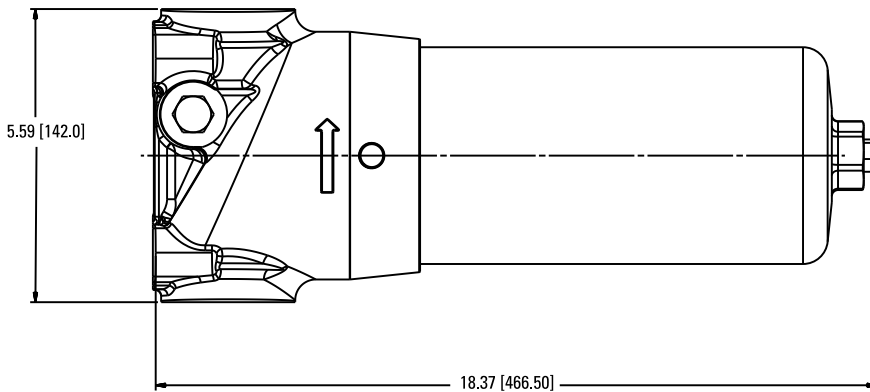
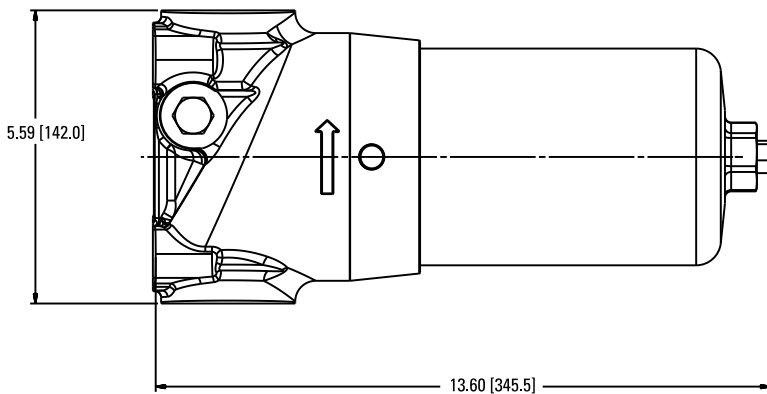
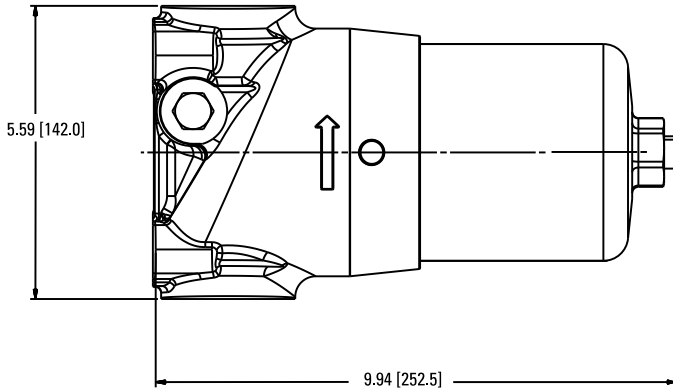

HEAD - TOP VIEW

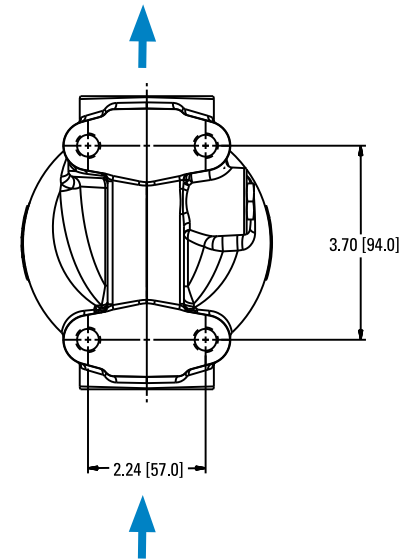



FPK04 Components

Filter Choices

Media Type	$\beta_{x(c)} = 1000$	$\beta_{x(c)} = 2$	Length		Part No.	Comments
	Rating based on ISO 16889		in	mm		
DT Synthetic	<4 μm		4.59	117	P566204	DT-9600-4-2UM
	5 μm		4.59	117	P566205	DT-9600-4-5UM
	5 μm		4.58	116.3	P167184	DT-9601-4-5UM, High Collapse
	8 μm		4.59	117	P566206	DT-9600-4-8UM
	12 μm		4.59	117	P566207	DT-9600-4-14UM
	12 μm		4.58	116.3	P167843	DT-9601-8-14UM, High Collapse
	23 μm		4.59	117	P566208	DT-9600-4-25UM
	<4 μm		8.22	209	P566209	DT-9600-8-2UM
	5 μm		8.22	209	P566210	DT-9600-8-5UM
	5 μm		8.20	208.3	P167185	DT-9601-4-14UM, High Collapse
	8 μm		8.22	209	P566211	DT-9600-8-8UM
	12 μm		8.22	209	P566212	DT-9600-8-14UM
	12 μm		8.20	208.3	P167186	DT-9601-13-5UM, High Collapse
	23 μm		8.22	209	P566213	DT-9600-8-25UM
	<4 μm		12.91	328	P566214	DT-9600-13-2UM
	5 μm		12.91	328	P566215	DT-9600-13-5UM
	5 μm		12.88	327.2	P167411	DT-9601-8-5UM, High Collapse
	8 μm		12.91	328	P566216	DT-9600-13-8UM
	12 μm		12.91	328	P566217	DT-9600-13-14UM
	12 μm		12.88	327.2	P167412	DT-9601-13-14UM, High Collapse
23 μm		12.91	328	P566218	DT-9600-13-25UM	
Water Absorbing		10 μm	8.20	208.3	P569528	9600 Absorbs 180 ml of water @ 25 psid
		10 μm	12.93	328.4	P569529	9600 Absorbs 220 ml of water @ 25 psid
Wire Mesh		75 μm	8.20	208.3	P162233	9600 Nitrile, Wire mesh



Filter Notes: All Donaldson DT filters utilize glass fiber media with an acrylic-based resin system for the ultimate in chemical compatibility. All Donaldson DT filters are potted with acrylic-based adhesives. Standard collapse DT designs are double wire-backed using acrylic-coated steel mesh for maximum pleat support and dirt capacity. Fluorocarbon seals are standard on all Donaldson DT filters. Refer to the table in the Technical Reference Guide for fluid compatibility with our filter media. If you're filtering diester, phosphate ester fluids, water glycol, water/oil emulsions, and HWCF over 150°F/83°C, use filters with seals made of fluorocarbon. High collapse designs are double wire-backed using stainless steel mesh. High collapse designs are also potted into machined aluminum endcaps for greater filter integrity in critical applications. Donaldson "high collapse" filters, with their steel end caps and wire-backed media, are rated to withstand up to 3000 psi/ 20,700 kPa before collapsing. The fluorocarbon seal/high collapse filters also use acrylic potting and media seam seals for added chemical compatibility.

Head Choices

Port Size	Bypass Rating	Indicators	Part No.
SAE-20	87 psi / 6 bar	plugged only	P568720
SAE-20	No bypass	plugged only	P568721

Housing Choices

Filter Length	Part No.
4.6" (116.8mm)	P568722
8.2" (208.3mm)	P568723
12.9" (327.7mm)	P568724

Notes: Housings include the head to housing seal.

Indicator Choices

Set Point / Type	Part No.
39 psi / 2.7 bar, electrical, normally open.	P574719
39 psi / 2.7 bar, electrical, normally closed, D.C. two-wire	P574967
39 psi / 2.7 bar, electrical, normally open, D.C. two-wire	P574968

FPK04 Service Parts

SERVICE PARTS NOTE:

Some service parts may not be stocked. Please contact your Donaldson sales representative for lead time details.

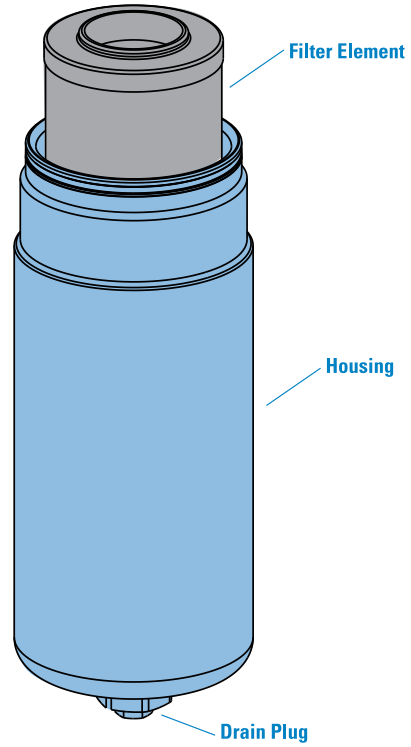
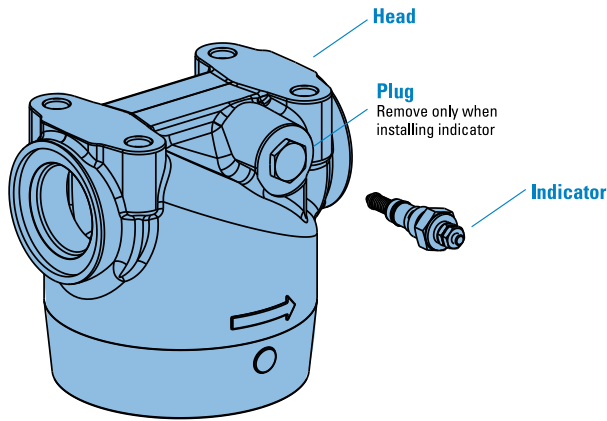

Performance Data





Performance Data

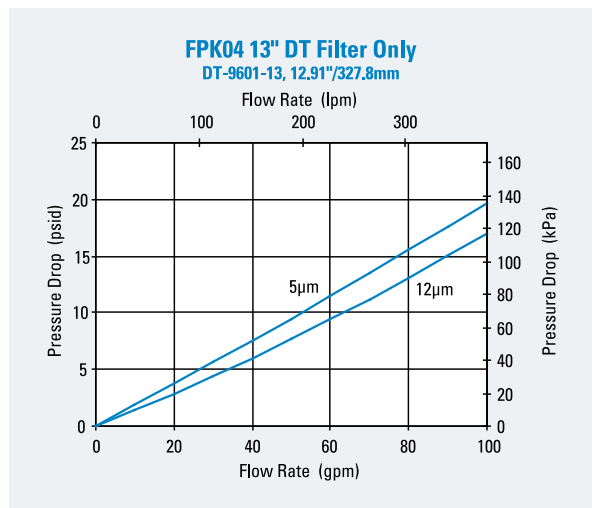
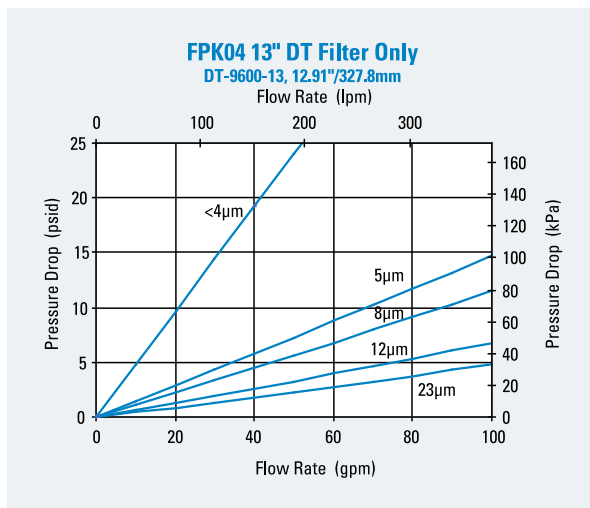
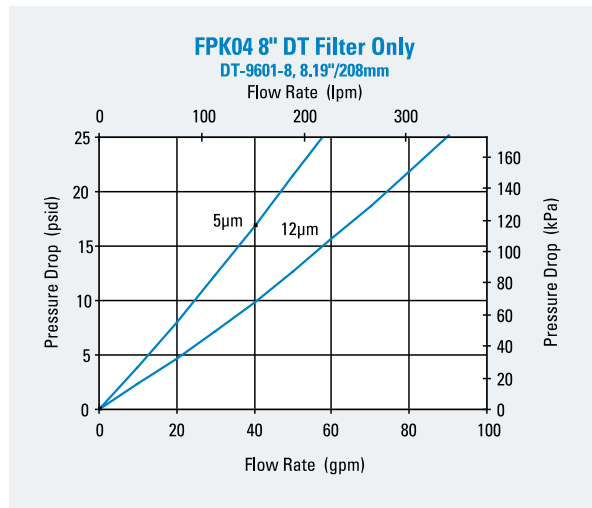
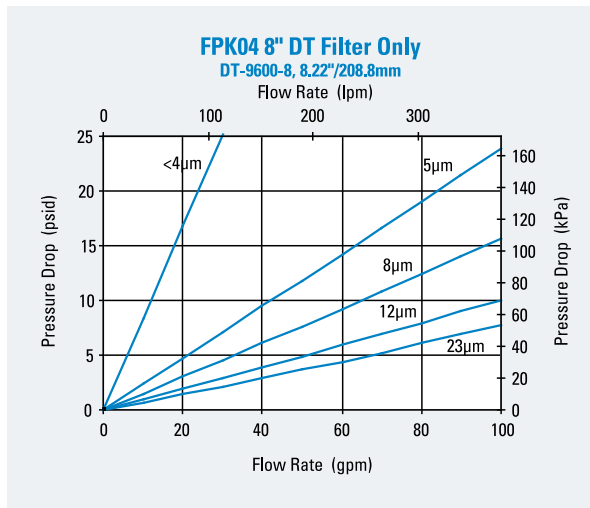
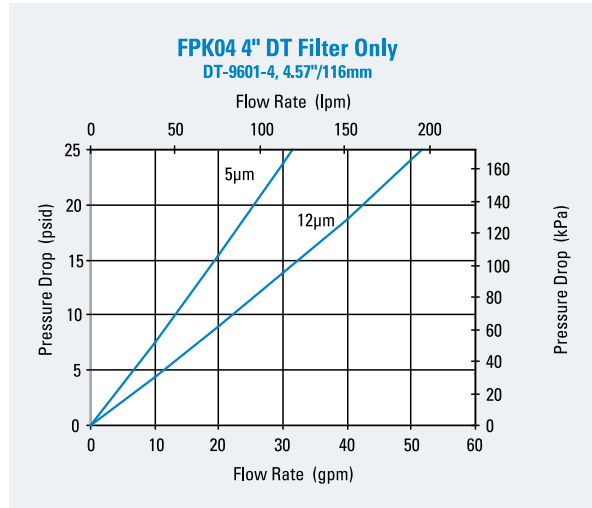
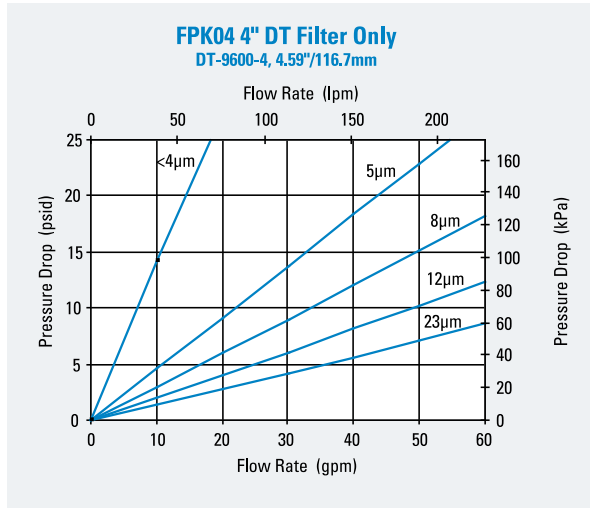

HPK04 In-Line Cartridge Filters

Working Pressures to:

6000 psi / 41,380 kPa / 413.8 bar

Rated Static Burst to:

17000 psi / 117,300 kPa / 1173 bar

Flow Range To:

120 gpm / 454 lpm

Applications

- High Pressure Circuits
- Hydrostatic Transmission
- Meets HF3 Specification
- Servo Valve Circuits



Features

The HPK04 high pressure filter series is made of ductile iron and steel for strength and durability. Machined bypass valves are case-hardened at critical points to provide maximum strength and reliability. Reverse flow bypass valve allows bi-directional flow through the filter head, and filter change out is simplified with standard housing drain plug. Meets HF3 specification. Take advantage of our mix and match system of in-stock heads, housings and cartridges – so you can get exactly what you need. Likewise, choose the media type and configuration that’s best for your application. Filter cartridges for HPK04 contain Synteq™, Donaldson’s exclusive synthetic fiber media formulated specially for liquid filtration. Upgraded Donaldson high-performance DT filters are also offered for superior performance.

Beta Rating

- Performance to $\beta_{<4(\mu)}=1000$

Porting Size Options

- SAE-20 O-Ring
- 1¼" or 1½" SAE 4-Bolt Flange Code 61 or 62

Replacement Filter Lengths

- 8.22" / 203mm
- 12.91" / 328mm
- 16.84" / 406mm

Standard Bypass Ratings

- 60 psi / 414 kPa / 4.1 bar
- 90 psi / 621 kPa / 6.2 bar with reverse-flow check valve
- No Bypass

Assembly Weight

- 8.22" Assembly: 41 lbs / 19 kg
- 12.91" Assembly: 48 lbs / 22 kg
- 16.84" Assembly: 52 lbs / 24 kg

Operating Temperatures

- -20°F to 250°F / -27°C to 121°C

Filter Collapse Ratings

- 290 psi / 1999 kPa / 20.0 bar (standard)
- 3000 psi / 20,700 kPa / 206.9 bar (high collapse)



HPK04

Max Flow: 120 gpm (454 lpm)



HPK04 Specification Illustrations

ASSEMBLY - SIDE VIEW

All dimensions are shown in inches [millimeters].

HEAD - TOP VIEW

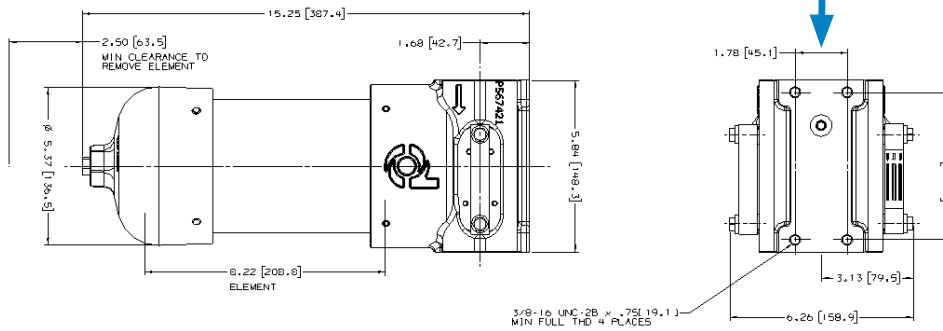

HPK04 with Visual Service Indicator

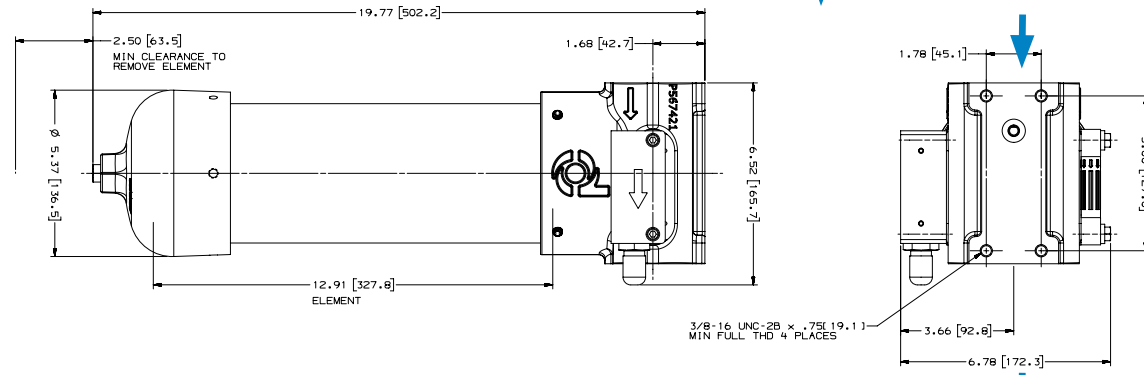

HPK04 with AC/DC Electrical Service Indicator

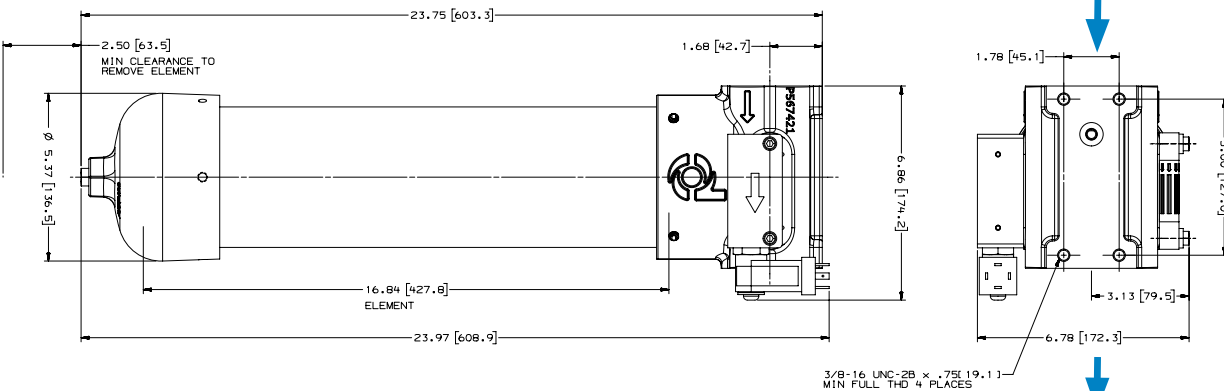

BYPASS VALVE ALTERNATIVES

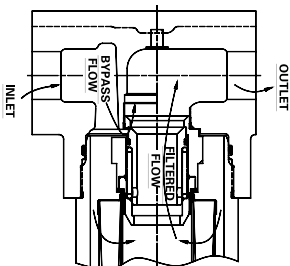

60 psi / 414 kPa Bypass Valve

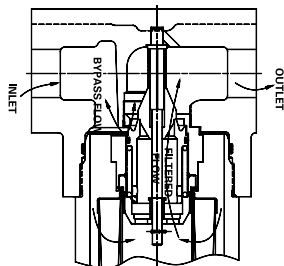

90 psi / 621 kPa Bypass Valve with Reverse Flow Check Valve

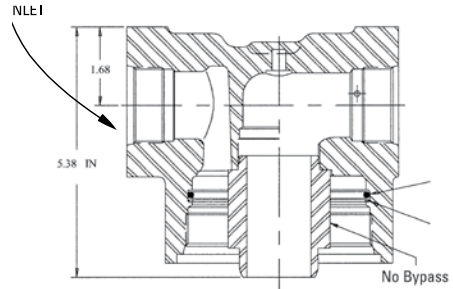

No Bypass

HPK04 Components

High-Performance DT Filter Choices

Media Type	$\beta_{x(c)} = 1000$	$\beta_{x(c)} = 2$	Length		Part No.	Comments
	Rating based on ISO 16889		in	mm		
DT Synthetic	<4 μm		8.22	209	P566209	DT-9600-8-2UM
	5 μm		8.22	209	P566210	DT-9600-8-5UM
	8 μm		8.22	209	P566211	DT-9600-8-8UM
	5 μm		8.20	208	P167185	DT-9601-8-5UM, High Collapse
	12 μm		8.22	209	P566212	DT-9600-8-14UM
	12 μm		8.20	208	P167186	DT-9601-13-14UM, High Collapse
	23 μm		8.22	209	P566213	DT-9600-8-25UM
	<4 μm		12.91	328	P566214	DT-9600-13-2UM
	5 μm		12.91	328	P566215	DT-9600-13-5UM
	5 μm		12.88	327	P167411	DT-9601-8-14UM, High Collapse
	8 μm		12.91	328	P566216	DT-9600-13-8UM
	12 μm		12.91	328	P566217	DT-9600-13-14UM
	12 μm		12.88	327	P167412	DT-9601-16-5UM, High Collapse
	23 μm		12.91	328	P566218	DT-9600-13-25UM
	<4 μm		16.84	428	P566219	DT-9600-16-2UM
	5 μm		16.84	428	P566220	DT-9600-16-5UM
	5 μm		16.83	427	P167187	DT-9601-16-5UM, High Collapse
	8 μm		16.84	428	P566221	DT-9600-16-8UM
	12 μm		16.84	428	P566222	DT-9600-16-14UM
	12 μm		16.83	427	P167188	DT-9601-16-14UM, High Collapse
23 μm		16.84	428	P566223	DT-9600-16-25UM	
Water Absorbing		10 μm	8.20	208	P569528	9600 Series, Absorbs 180 ml water @ 25 psid
		10 μm	12.93	328	P569529	9600 Series, Absorbs 220 ml water @ 25 psid
		10 μm	16.83	427	P569530	9600 Series, Absorbs 300 ml water @ 25 psid
Wire Mesh		75 μm	8.20	208	P162233	9600 Series, Nitrile



Filter Notes: All Donaldson DT filters utilize glass fiber media with an acrylic-based resin system for the ultimate in chemical compatibility. All Donaldson DT filters are potted with acrylic-based adhesives. Standard collapse DT designs are double wire-backed using acrylic-coated steel mesh for maximum pleat support and dirt capacity. Fluorocarbon seals are standard on all Donaldson DT filters. High collapse designs are double wire-backed using stainless steel mesh. High collapse designs are also potted into machined aluminum endcaps for greater filter integrity in critical applications. Filters with seals made of fluorocarbon are required when using diester, phosphate ester fluids, water glycol, water/oil emulsions, and HWCF (high water content fluids) over 150°F/83°C. The fluorocarbon seal, high collapse filters also use acrylic potting and media seam seals for added chemical compatibility. Donaldson high collapse filters are physically designed to withstand up to 3000 psi/ 20,700 kPa before collapsing.



HPK04

Max Flow: 120 gpm (454 lpm)



Housing Choices

Length		Part No.
in	mm	
8	203	P567650
13	330	P567649
16	406	P567648

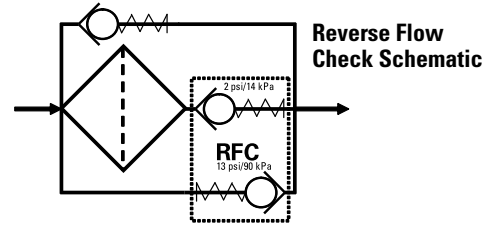

Head Choices

Port Size	Working Pressure	Bypass Rating	Indicators ¹	Part No.
1½" SAE 4-Bolt (Code 61) with SAE-20 O-Ring	3000 psi/207 bar	60 psi/4.1 bar	Visual left side, blank plate right side	P567639
1½" SAE 4-Bolt (Code 61) with SAE-20 O-Ring	3000 psi/207 bar	90 psi/6.2 bar with reverse flow check valve	Visual left side, blank plate right side	P567640
1½" SAE 4-Bolt (Code 61) with SAE-20 O-Ring	3000 psi/207 bar	no bypass	Visual left side, blank plate right side	P567641
1½" SAE 4-Bolt (Code 62)	6000 psi/414 bar	60 psi/4.1 bar	Visual left side, blank plate right side	P567642
1½" SAE 4-Bolt (Code 62)	6000 psi/414 bar	90 psi/6.2 bar with reverse flow check valve	Visual left side, blank plate right side	P567643
1¼" SAE 4-Bolt (Code 62)	6000 psi/414 bar	90 psi/6.2 bar with reverse flow check valve	Visual left side, blank plate right side	P567644
1¼" SAE 4-Bolt (Code 62)	6000 psi/414 bar	90 psi/6.2 bar with reverse flow check valve	Blank left side, blank plate right side	P574189

Notes on Indicators

¹Donaldson uses the inlet port as the reference point. "Left side," for instance, means that the indicator mounts on the side of the filter head that is on your left when you face the inlet port.

Service Indicator Kits (All kits include indicator with mounting block)

Part No.	Bypass Valve Pressure of:	Description
Visual Service Indicators		
P569632	60 psi / 4.1 bar	35 psi/2.4 bar indicator kit auto reset pop-out button
P569633	90 psi / 6.2 bar	70 psi/4.8 bar indicator kit auto reset pop-out button
P567988	60 psi / 4.1 bar	35 psi/2.4 bar indicator kit auto reset pop-out button with thermal lockout and surge control
P567989	90 psi / 6.2 bar	70 psi/4.8 bar indicator kit* auto reset pop-out button with thermal lockout and surge control
AC/DC Visual/Electrical Service Indicators		
P569634	60 psi / 4.1 bar	35 psi/2.4 bar indicator kit Hirschmann receptacle 115 VAC/28 VDC, 2 amps
P569635	90 psi / 6.2 bar	70 psi/4.8 bar indicator kit Hirschmann receptacle 115 VAC/28 VDC, 2 amps
P567986	60 psi / 4.1 bar	35 psi/2.4 bar indicator kit with thermal lockout and surge control, Hirschmann receptacle, 115 VAC/28 VDC, 2 amps, 4 pin DIN 43650
P567987	90 psi / 6.2 bar	70 psi/4.8 bar indicator kit with thermal lockout and surge control, Hirschmann receptacle, 115 VAC/28 VDC, 2 amps, 4 pin DIN 43650

Indicator Choices (Replacement Indicator Only)

Part No.	Description	Part No.	Description
P567458	Visual/Electrical indicator with thermal lockout and surge, 35 psid/2.4 bar	P569637	Pop-Up Visual Indicator, 70 psid/4.8 bar
P567459	Visual/Electrical indicator, with thermal lockout and surge, 70 psid/4.8 bar	P164315	Visual Indicator, bar style, 35 psid/2.4 bar
P567456	Pop-Up Visual Indicator, with thermal lockout and surge, 35 psid/2.4 bar	P166603	Visual Indicator, bar style, 70 psid/4.8 bar
P569636	Pop-Up Visual Indicator, 35 psid/2.4 bar	P166134	Blanking plate
Indicator Mounting Block			
P573495	Mounting Block Assembly		



Performance Data

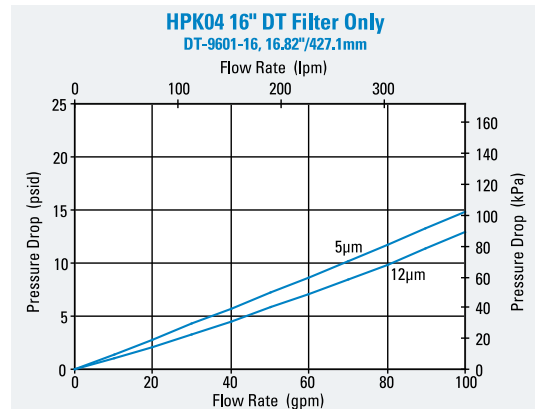
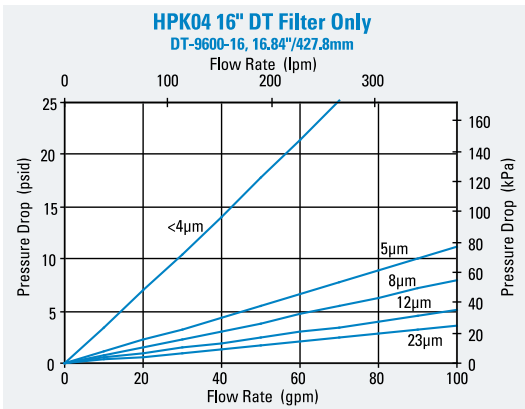
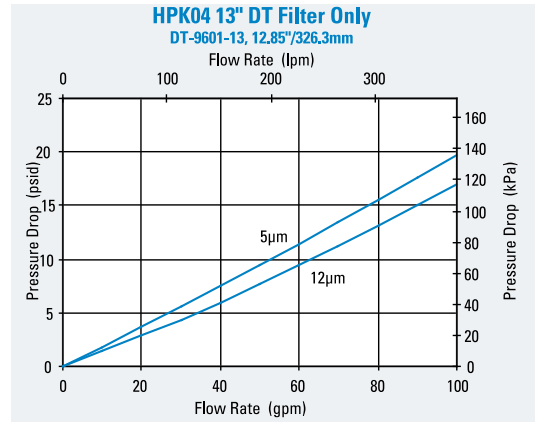
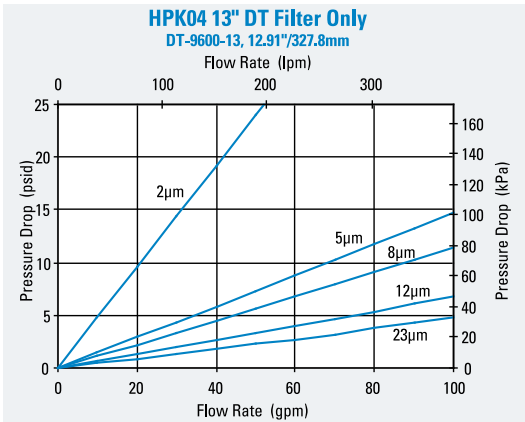
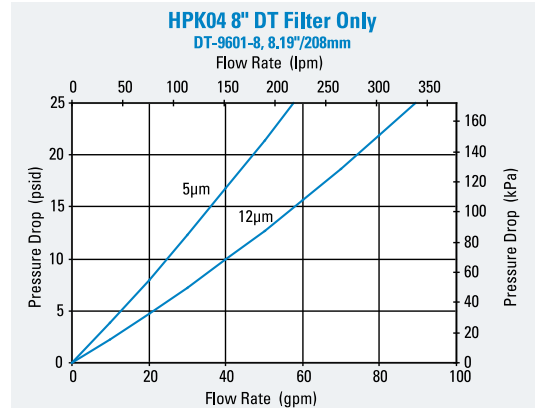
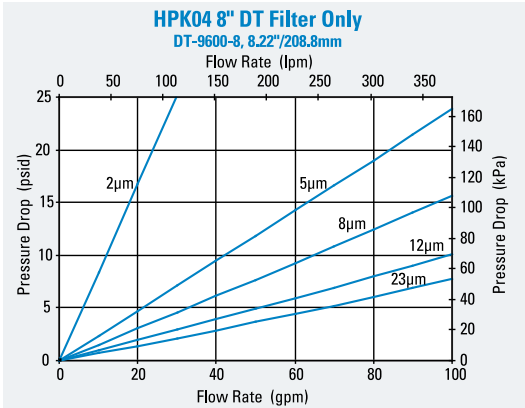
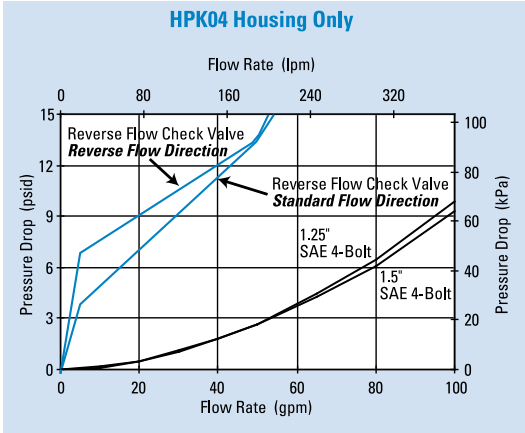



HPK04

Max Flow: 120 gpm (454 lpm)



HPK04 Service Parts

SERVICE PARTS NOTE:

Some service parts may not be stocked. Please contact your Donaldson sales representative for lead time details.

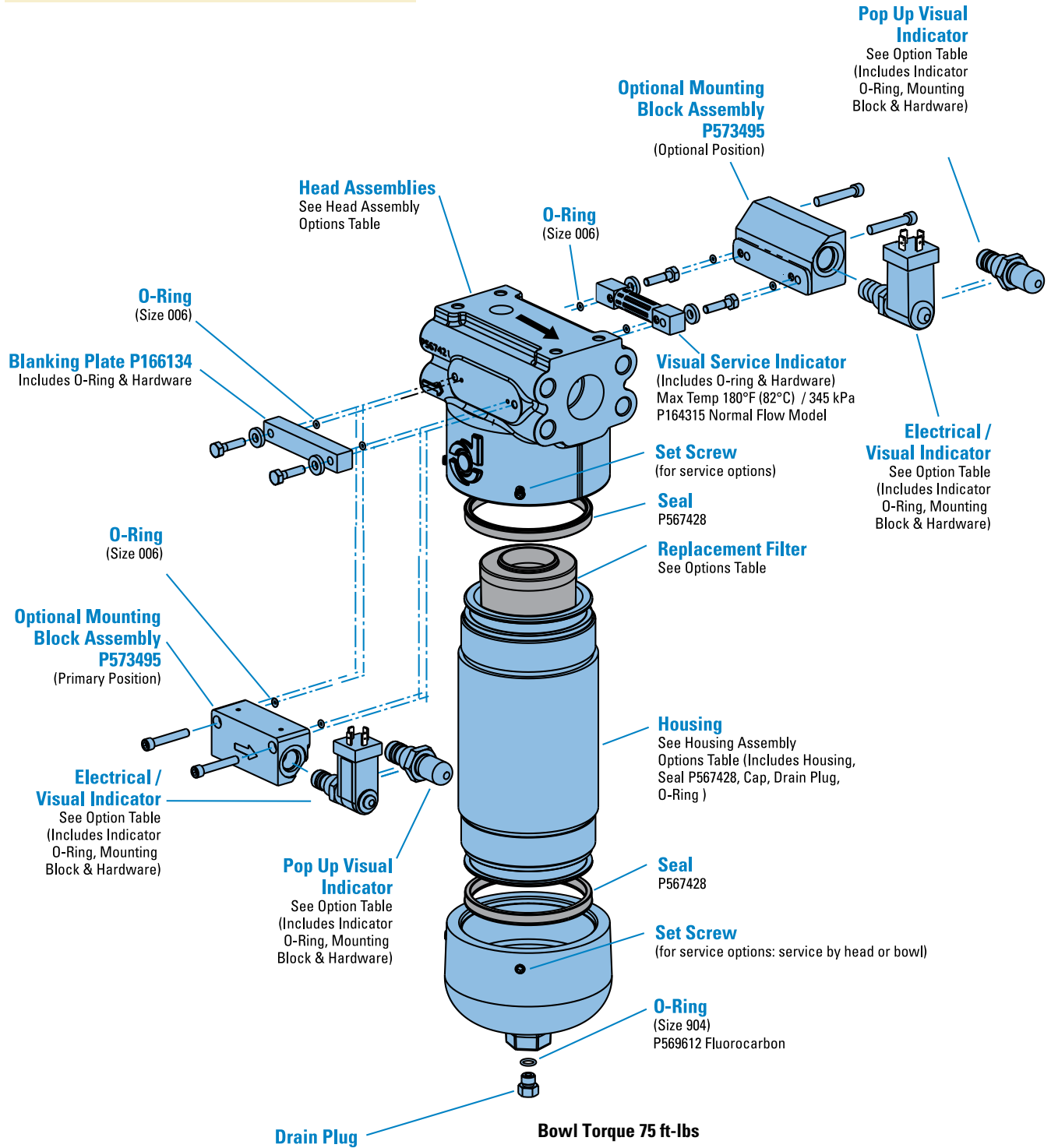

W451 In-Line Cartridge Filters

Working Pressures to:

6,000 psi / 41,369 kPa / 414 bar

Rated Static Burst to:

13,500 psi / 93,100 kPa / 931 bar

Fatigue Pressure Rating:

3000 psi / 20,700 kPa / 207 bar

Flow Range To:

150 gpm / 568 lpm

Applications

- High Pressure Circuits
- In-Plant Systems
- Meets HF4 Specification
- Mobile Equipment



Features

The W451 base-mounted filter series provides for easy servicing featuring top cover access for filter changeout. The ductile iron filter head design provides for SAE ports along with optional space saving manifold mounting. This product features the popular HF4 automotive filter. DT 4-layer media is offered in a variety of designs. Four different media grades are offered. Filter core collapse options range from 150 to 3,000 psi. The differential pressure indicator line is designed to work with the wide assortment of bypass valves. Thermal lockout and surge control are two key features available in many of the differential pressure indicators.

- Conforms to HF4 specifications
- High collapse filter available for use with non-bypass applications
- Wide range of indicator options
- Three housing length options for design flexibility
- Base & cover material: cast iron
- Cylinder material: steel
- Drain plug in base
- Bleed/fill plug in cover

Beta Rating

- Performance to $\beta_{5(\mu)}=1000$

Porting Size Options

- SAE-24 O-Ring
- 1½" SAE 4-Bolt Flange Code 61 or 62
- Manifold Mounting

Replacement Filter Lengths

- 9.12" / 231.8mm
- 18.20" / 462.3mm
- 27.66" / 702.5mm

Standard Bypass Ratings

- 50 psi / 345 kPa / 3.5 bar
- 90 psi / 621 kPa / 6.2 bar
- No Bypass

Assembly Weight

- 9.28": 56 lbs / 25.4 kg
- 18.32": 82 lbs / 37.5 kg
- 27.75": 109 lbs / 49.5 kg

Operating Temperatures

- -45° to 250°F (-43° to 121°C)

Filter Collapse Ratings

- 150 psi / 1034 kPa / 10.3 bar (standard)
- 3000 psi / 20,700 kPa / 206.8 bar (high collapse)



W451

Max Flow: 150 gpm (568 lpm)



W451 Specification Illustrations

ASSEMBLY - SIDE VIEW

All dimensions are shown in millimeters [inches].

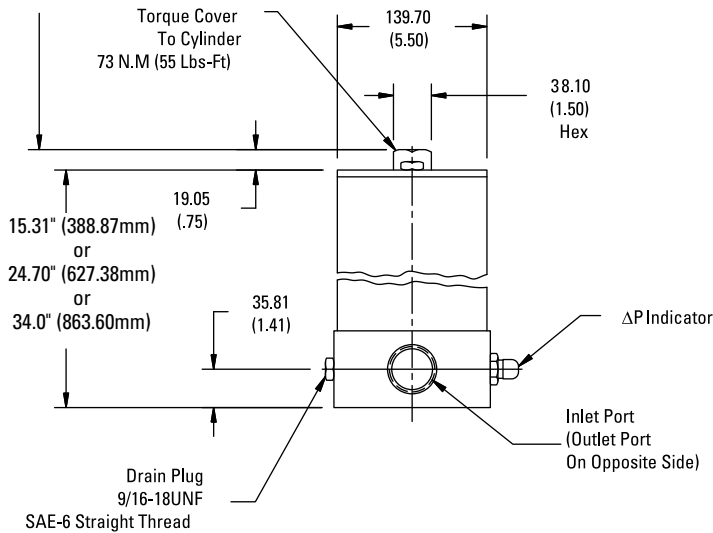

HEAD - SIDE VIEW

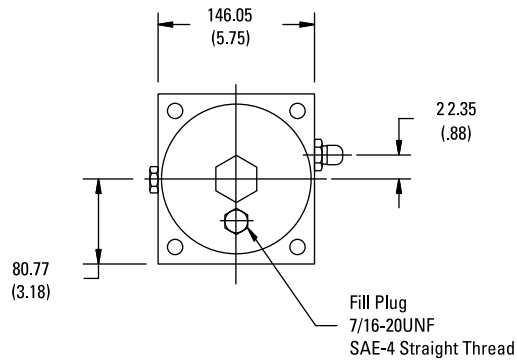

HEAD - BOTTOM VIEW

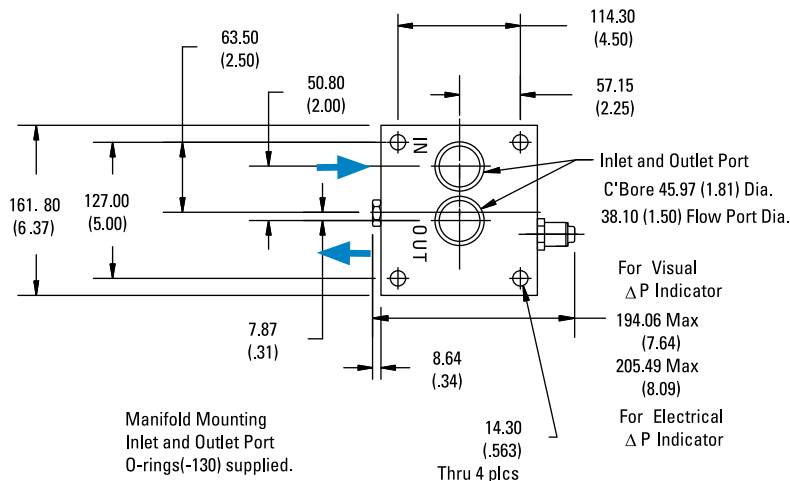



W451 Components

Filter Choices

Media Type	$\beta_{x(c)} = 2$	$\beta_{x(c)} = 1000$	Length		Part No.	Comments
	Rating based on ISO 16889		in	mm		
DT Synthetic		<4 μm	9.04	230	P568816	DT-HF4-9-2UM
		5 μm	9.28	236	P566270	DT-HF4-9-5UM
		8 μm	9.28	236	P566271	DT-HF4-9-8UM
		12 μm	9.28	236	P566272	DT-HF4-9-14UM
		23 μm	9.28	236	P566273	DT-HF4-9-25UM
		5 μm	9.27	229	P566412	DT-HF4HC-9-5UM, High collapse
		12 μm	9.27	229	P566413	DT-HF4HC-9-14UM, High collapse
		<4 μm	18.19	232	P568817	DT-HF4-18-2UM
		5 μm	18.32	465	P566274	DT-HF4-18-5UM
		8 μm	18.32	465	P566275	DT-HF4-18-8UM
		12 μm	18.32	465	P566276	DT-HF4-18-14UM
		23 μm	18.32	465	P566277	DT-HF4-18-25UM
		5 μm	18.60	472	P572309	DT-HF4HC-18-5UM, High collapse
		12 μm	18.60	472	P572310	DT-HF4HC-18-14UM, High collapse
		<4 μm	27.47	698	P568818	DT-HF4-27-2UM
		5 μm	27.75	705	P566278	DT-HF4-27-5UM
		8 μm	27.75	705	P566279	DT-HF4-27-8UM
		12 μm	27.75	705	P566280	DT-HF4-27-14UM
		23 μm	27.75	705	P566281	DT-HF4-27-25UM
		5 μm	27.93	709	P572311	DT-HF4HC-27-5UM, High collapse
	12 μm	27.93	709	P572312	DT-HF4HC-27-14UM, High collapse	
Water Absorbing	10 μm		9.27	236	P569527	Absorbs 250 ml water @ 25 psid

Filter Notes: All Donaldson DT filters utilize glass fiber media with an acrylic-based resin system for the ultimate in chemical compatibility. All Donaldson DT filters are potted with acrylic-based adhesives. Standard collapse DT designs are double wire-backed using acrylic-coated steel mesh for maximum pleat support and dirt capacity. High collapse designs are double wire-backed using stainless steel mesh. High collapse designs are also potted into machined aluminum end caps for greater filter integrity in critical applications. May be stacked with two or three 9" long filters (P167324). Fluorocarbon seals are standard on all Donaldson DT filters.

Performance Data

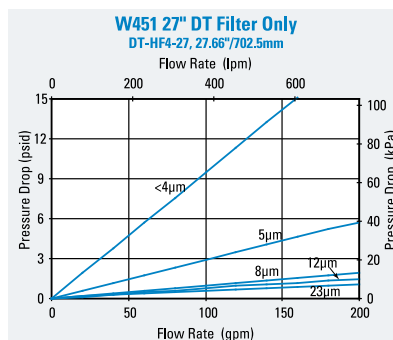
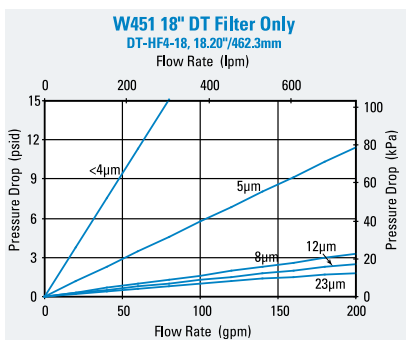
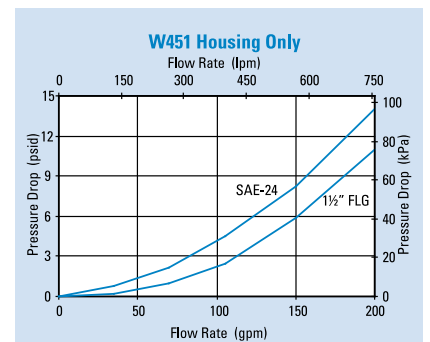
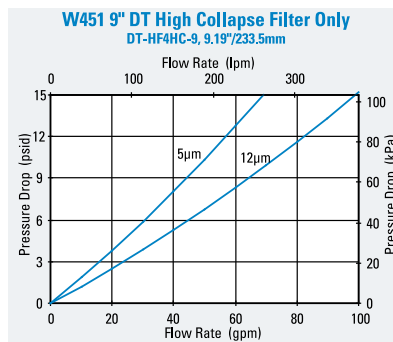
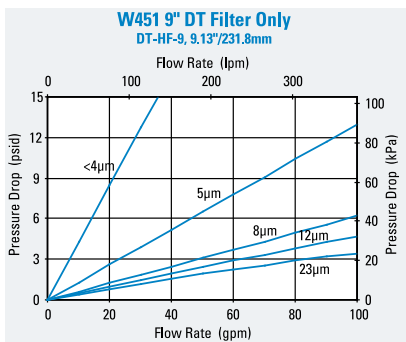



W451

Max Flow: 150 gpm (568 lpm)



Filter Assembly Choices

Port Size	Working Pressure (PSI)	Bypass Rating	Seal Material	Indicator Style & Location	Housing Length	Assembly Length	Part No.
SAE-24 O-Ring	5500 psi / 379 bar	50 psi / 3.45 bar	Nitrile	Port Machined & Plugged	9" (228.6mm)	15.31" (338.9mm)	P574220
SAE-24 O-Ring	5500 psi / 379 bar	50 psi / 3.45 bar	Nitrile	Port Machined & Plugged	18" (457.2mm)	24.7" (627.3mm)	P574221
SAE-24 O-Ring	5500 psi / 379 bar	50 psi / 3.45 bar	Nitrile	Port Machined & Plugged	27" (685.8mm)	34.0" (863.6mm)	P574222
1-1/2" SAE 4 Bolt Flange, Code 61	5500 psi / 379 bar	50 psi / 3.45 bar	Nitrile	Port Machined & Plugged	18" (457.2mm)	24.7" (627.3mm)	P574223
1-1/2" SAE 4 Bolt Flange, Code 61	5500 psi / 379 bar	50 psi / 3.45 bar	Nitrile	Port Machined & Plugged	27" (685.8mm)	34.0" (863.6mm)	P574224
1-1/2" SAE 4 Bolt Flange, Code 61	5500 psi / 379 bar	90 psi / 6.21 bar	Nitrile	Port Machined & Plugged	18" (457.2mm)	24.7" (627.3mm)	P574225
1-1/2" SAE 4 Bolt Flange, Code 62	6000 psi / 414 bar	50 psi / 3.45 bar	Nitrile	Port Machined & Plugged	18" (457.2mm)	24.7" (627.3mm)	P574226
Manifold Mount	5500 psi / 379 bar	50 psi / 3.45 bar	Nitrile	Port Machined & Plugged	18" (457.2mm)	24.7" (627.3mm)	P574227
Manifold Mount	5500 psi / 379 bar	50 psi / 3.45 bar	Nitrile	Port Machined & Plugged	27" (685.8mm)	34.0" (863.6mm)	P574228
Manifold Mount	5500 psi / 379 bar	None	Nitrile	Port Machined & Plugged	9" (228.6mm)	15.31" (338.9mm)	P574229
Manifold Mount	5500 psi / 379 bar	None	Nitrile	Port Machined & Plugged	18" (457.2mm)	24.7" (627.3mm)	P574230
SAE-24 O-Ring	5500 psi / 379 bar	None	Fluorocarbon	Port Machined & Plugged	18" (457.2mm)	24.7" (627.3mm)	P575915
SAE-24 O-Ring	5500 psi / 379 bar	None	Fluorocarbon	Port Machined & Plugged	27" (685.8mm)	34.0" (863.6mm)	P575916
SAE-24 O-Ring	5500 psi / 379 bar	None	Fluorocarbon	Port Machined & Plugged	9" (228.6mm)	15.31" (338.9mm)	P575917
1-1/2" SAE 4 Bolt Flange, Code 61	5500 psi / 379 bar	None	Fluorocarbon	Port Machined & Plugged	18" (457.2mm)	24.7" (627.3mm)	P575918
1-1/2" SAE 4 Bolt Flange, Code 61	5500 psi / 379 bar	90 psi / 6.21 bar	Fluorocarbon	Port Machined & Plugged	9" (228.6mm)	15.31" (338.9mm)	P575919

Indicator Choices

Indicator Pressure Setting	Connector Style	Seal Material	Part No.	Thermal Lockout	Surge Control	Reset
Visual Pop-up Models						
35 psi / 241 kPa	NA	Nitrile	P572347	No	No	Auto
35 psi / 241 kPa	NA	Nitrile	P572348	Yes	Yes	Manual
35 psi / 241 kPa	NA	Fluorocarbon	P567456	Yes	Yes	Manual
70 psid / 482 kPa	NA	Nitrile	P572319	Yes	Yes	Manual
100 psid / 690 kPa	NA	Nitrile	P572353	Yes	Yes	Manual
100 psid / 690 kPa	NA	Fluorocarbon	P572354	Yes	Yes	Manual
Electrical / Visual Models						
35 psi / 241 kPa	Hirschman	Nitrile	P572327	No	No	Auto
35 psi / 241 kPa	Hirschman	Nitrile	P572384	Yes	Yes	Manual
35 psi / 241 kPa	Hirschman	Fluorocarbon	P567458	Yes	Yes	Manual
35 psi / 241 kPa	Brad Harrison	Nitrile	P572385	Yes	Yes	Manual
35 psi / 241 kPa	3 wire flying leads	Nitrile	P572349	No	No	Auto
70 psi / 482 kPa	Hirschman	Nitrile	P572320	Yes	Yes	Manual
70 psi / 482 kPa	Hirschman	Fluorocarbon	P567459	Yes	Yes	Manual
100 psi / 690 kPa	Hirschman	Nitrile	P572387	Yes	Yes	Manual
Electrical Models						
35 psi / 241 kPa	Hirschman	Nitrile	P572359	No	No	Auto
70 psi / 482 kPa	Hirschman	Nitrile	P572369	No	No	Auto

Service Part Choices

Part No.	Description
X011174	Head/Bowl/Housing seal kit - nitrile
X011175	Head/Bowl/Housing seal kit - fluorocarbon

W620 In-Line Cartridge Filters

Working Pressures to:

6000 psi / 41,380 kPa / 413.8 bar

Rated Static Burst to:

15,000 psi / 103,400 kPa / 1034 bar

Fatigue Pressure Rating:

3000 psi / 20,700 kPa / 207 bar

Flow Range To:

150 gpm / 568 lpm

Applications

- High Pressure Circuits
- In-Plant Systems
- Meets HF3 Specification
- Mobile Equipment

Features

The W620 filter assembly contains the popular HF3 filter. It offers a reverse flow bypass valve option available for hydrostatic transmissions. Donaldson DT high-performance 4-layer media is offered in a variety of designs. The differential pressure indicator line is designed to work with the wide assortment of bypass valves. Thermal lockout and surge control are two key features incorporated in many of the differential pressure indicators.

- Conforms to HF3 specifications
- Head material: cast iron
- Housing material: steel
- Reverse flow bypass valve option available



Beta Rating

- Performance to $\beta_{<di>0.5</di>}=1000$

Porting Size Options

- SAE-16, SAE-20, SAE-24 O-Ring
- 1¼" SAE 4-Bolt Flange Code 62
- 1½" SAE 4-Bolt Flange Code 61

Replacement Filter Lengths

- 4.59" / 116.6mm
- 8.22" / 203.2mm
- 12.91" / 330.2mm
- 16.84" / 406.4mm

Standard Bypass Ratings

- 50 psi / 345 kPa / 3.5 bar
- 90 psi / 621 kPa / 6.2 bar

Assembly Weight

- 9.00": 23 lbs / 10.43 kg
- 13.00": 33 lbs / 14.97 kg
- 18.00": 42 lbs / 19.05 kg
- 22.00": 48 lbs / 21.77 kg

Operating Temperatures

- -20° to 250°F (-29° to 121°C)

Filter Collapse Ratings

- 290 psi / 1999 kPa / 20.0 bar (standard)
- 3000 psi / 20,700 kPa / 206.8 bar (high collapse)



W620

Max Flow: 150 gpm (568 lpm)



W620 Specification Illustrations

ASSEMBLY - SIDE VIEW

All dimensions are shown in millimeters [inches].

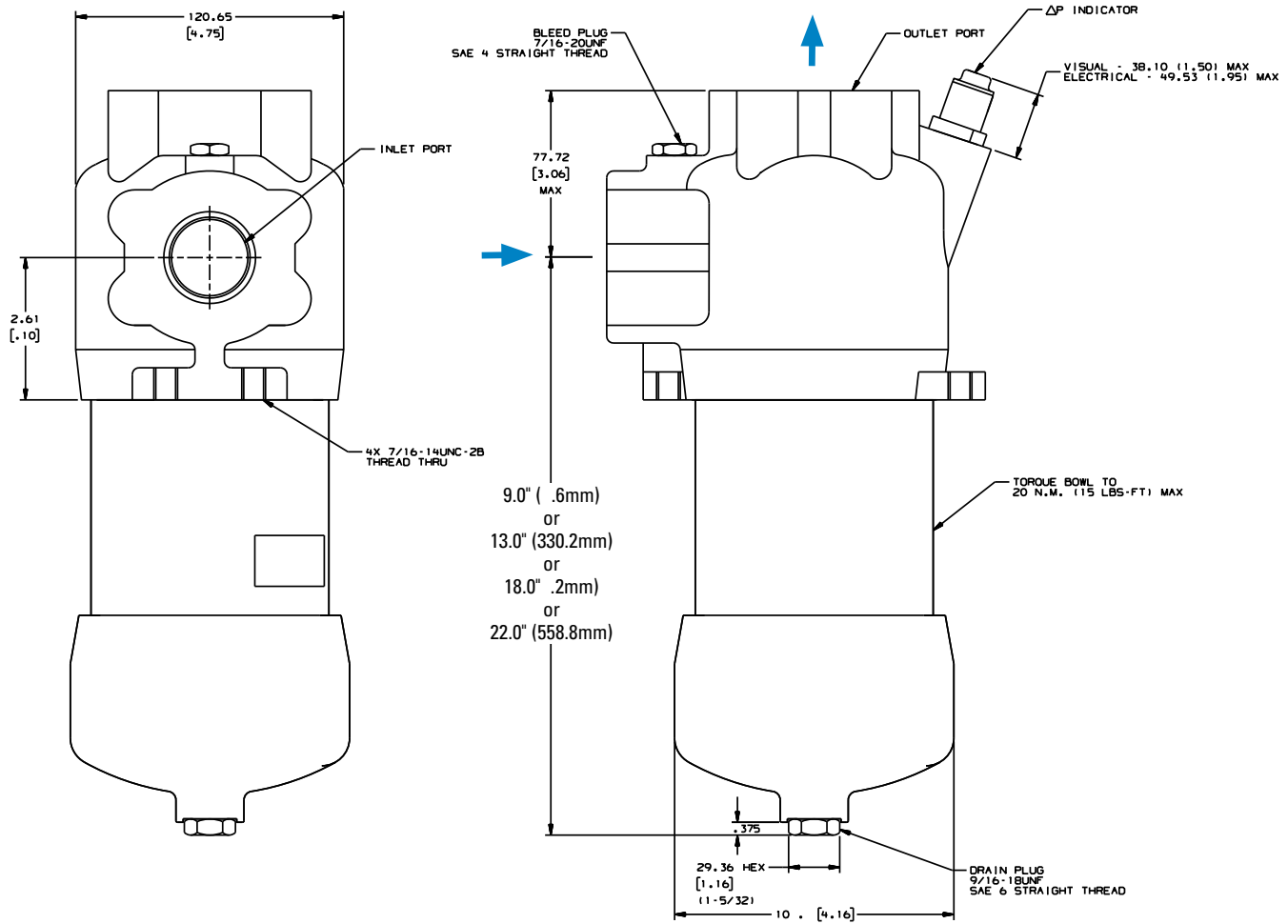

HEAD - TOP VIEW

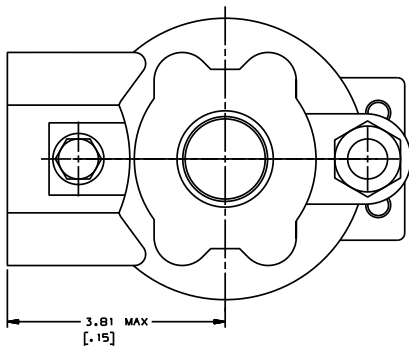



W620 Components

Filter Choices

Media Type	$\beta_{x(c)} = 1000$	Length		Part No.	Comments
	Rating based on ISO 16889	in	mm		
DT Synthetic	<4 μm	4.59	117	P566204	DT-9600-4-2UM
	5 μm	4.59	117	P566205	DT-9600-4-5UM
	5 μm	4.56	116	P167184	DT-9601-4-5UM, High Collapse
	8 μm	4.59	117	P566206	DT-9600-4-8UM
	12 μm	4.59	117	P566207	DT-9600-4-14UM
	12 μm	4.56	116	P167843	DT-9601-4-14UM, High Collapse
	23 μm	4.59	117	P566208	DT-9600-4-25UM
	<4 μm	8.22	209	P566209	DT-9600-8-2UM
	5 μm	8.22	209	P566210	DT-9600-8-5UM
	5 μm	8.19	208	P167185	DT-9601-8-5UM, High Collapse
	8 μm	8.22	209	P566211	DT-9600-8-8UM
	12 μm	8.22	209	P566212	DT-9600-8-14UM
	12 μm	8.19	208	P167186	DT-9601-8-14UM, High Collapse
	23 μm	8.22	209	P566213	DT-9600-8-25UM
	<4 μm	12.91	328	P566214	DT-9600-13-2UM
	5 μm	12.91	328	P566215	DT-9600-13-5UM
	5 μm	12.85	326	P167411	DT-9601-13-5UM, High Collapse
	8 μm	12.91	328	P566216	DT-9600-13-8UM
	12 μm	12.91	328	P566217	DT-9600-13-14UM
	12 μm	12.85	326	P167412	DT-9601-13-14UM, High Collapse
	23 μm	12.91	328	P566218	DT-9600-13-25UM
	<4 μm	16.84	428	P566219	DT-9600-16-2UM
	5 μm	16.84	428	P566220	DT-9600-16-5UM
	5 μm	16.84	428	P167187	DT-9601-16-5UM, High Collapse
	8 μm	16.84	428	P566221	DT-9600-16-8UM
	12 μm	16.84	428	P566222	DT-9600-16-14UM
	12 μm	16.84	428	P167188	DT-9601-16-14UM, High Collapse
	23 μm	16.84	428	P566223	DT-9600-16-25UM



Filter Notes: All Donaldson DT filters utilize glass fiber media with an acrylic-based resin system for the ultimate in chemical compatibility. All Donaldson DT filters are potted with acrylic-based adhesives. Standard collapse DT designs are double wire-backed using acrylic-coated steel mesh for maximum pleat support and dirt capacity. Fluorocarbon seals are standard on all Donaldson DT filters. Donaldson "high collapse" filters, with their steel end caps and wire-backed media, are rated to withstand up to 3000 psi/ 20,700 kPa before collapsing. High collapse designs are also potted into machined aluminum endcaps for greater filter integrity in critical applications. The fluorocarbon seal/high collapse filters also use acrylic potting and media seam seals for added chemical compatibility. High collapse designs are double wire-backed using stainless steel mesh. High collapse designs are double wire-backed using stainless steel mesh. High collapse designs are also potted into machined aluminum endcaps for greater filter integrity in critical applications.



W620

Max Flow: 150 gpm (568 lpm)



Head Assembly Choices

Port Size	Bypass Rating	Seal Material	Indicator Style & Location	Part No.	Comments
SAE-16 O-Ring	50 psi / 3.45 bar	Nitrile	Port Machined & Plugged	P574252	
SAE-24 O-Ring	50 psi / 3.45 bar	Nitrile	Port Machined & Plugged	P574253	
1-1/2" SAE 4 Bolt Flange, Code 61	50 psi / 3.45 bar	Nitrile	Port Machined & Plugged	P574254	3000 PSI Maximum Pressure
1-1/4" SAE 4 Bolt Flange, Code 62	50 psi / 3.45 bar	Fluorocarbon	Port Machined & Plugged	P575931	Reverse flow check valve
1-1/4" SAE 4 Bolt Flange, Code 62	50 psi / 3.45 bar	Fluorocarbon	Port Machined & Plugged	P575932	
SAE-16 O-Ring	90 psi / 6.21 bar	Fluorocarbon	Port Machined & Plugged	P575933	
SAE-20 O-Ring	50 psi / 3.45 bar	Fluorocarbon	Port Machined & Plugged	P575934	
SAE-20 O-Ring	50 psi / 3.45 bar	Fluorocarbon	Port Machined & Plugged	P575935	Reverse flow check valve

Housing Choices

Housing Length	Seal Material	Part No.
4" (101.1mm)	Nitrile	X011557
8" (203.2mm)	Nitrile	X011559
13" (330.2mm)	Nitrile	X011554
16" (406.4mm)	Nitrile	X011555

Service Part Choices

Part No.	Description
X011182	Head/Bowl/Housing Seal Kit - nitrile
X011183	Head/Bowl/Housing Seal Kit - fluorocarbon

Indicator Choices

Indicator Pressure Setting	Connector Style	Seal Material	Part No.	Thermal Lockout	Surge Control	Reset
Visual Pop-up Models						
35 psi / 241 kPa	NA	Nitrile	P572347	No	No	Auto
35 psi / 241 kPa	NA	Nitrile	P572348	Yes	Yes	Manual
35 psi / 241 kPa	NA	Fluorocarbon	P567456	Yes	Yes	Manual
70 psid / 482 kPa	NA	Nitrile	P572319	Yes	Yes	Manual
Electrical / Visual Models						
35 psi / 241 kPa	Hirschman	Nitrile	P572327	No	No	Auto
35 psi / 241 kPa	Hirschman	Nitrile	P572384	Yes	Yes	Manual
35 psi / 241 kPa	Hirschman	Fluorocarbon	P567458	Yes	Yes	Manual
35 psi / 241 kPa	Brad Harrison	Nitrile	P572385	Yes	Yes	Manual
35 psi / 241 kPa	3 wire flying leads	Nitrile	P572349	No	No	Auto
70 psi / 482 kPa	Hirschman	Nitrile	P572320	Yes	Yes	Manual
70 psi / 482 kPa	Hirschman	Fluorocarbon	P567459	Yes	Yes	Manual
Electrical Models						
35 psi / 241 kPa	Hirschman	Nitrile	P572359	No	No	Auto
70 psi / 482 kPa	Hirschman	Nitrile	P572369	No	No	Auto



Performance Data

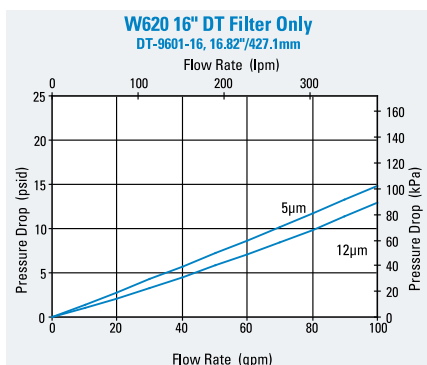
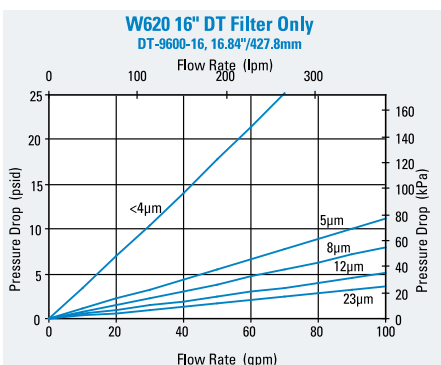
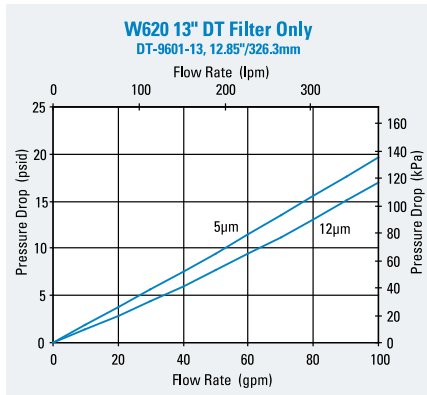
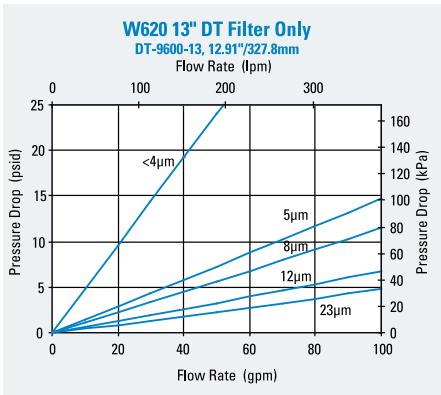
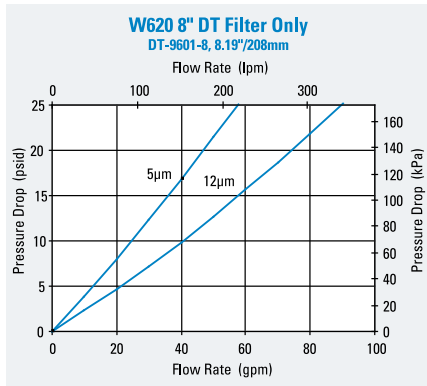
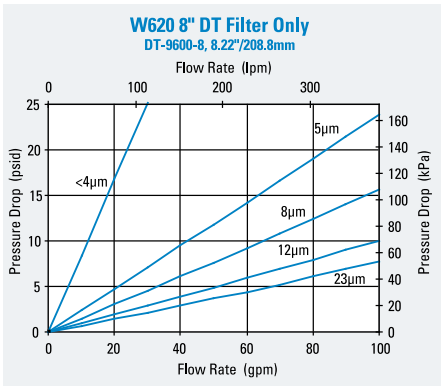
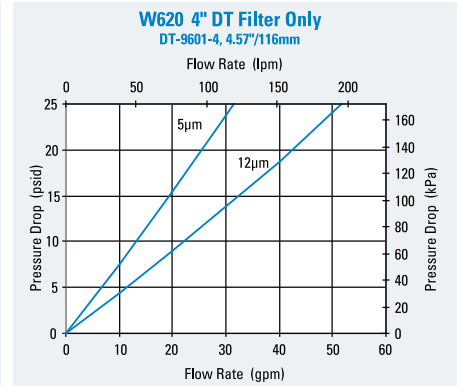
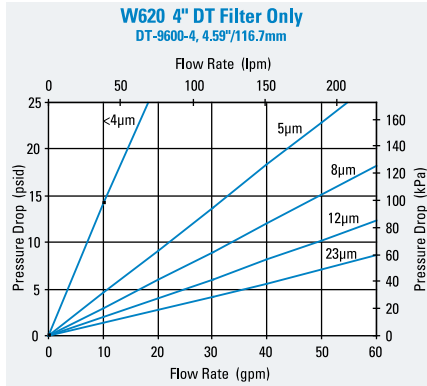
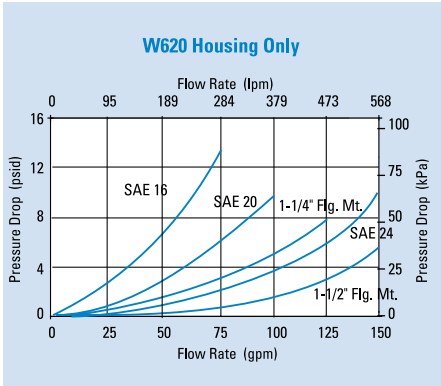



HPK05

Max Flow: 200 gpm (757 lpm)



HPK05 In-Line Cartridge Filters

Rated Static Burst to:

8267 psi / 57,000 kPa / 570 bar

Flow Range To:

200 gpm / 757 lpm

Applications

- High Pressure Circuits
- Hydrostatic Transmission
- In-Plant Systems
- Lube Oil Systems
- Mobile Equipment



Features

Donaldson's HPK05 high pressure filters are designed to protect sensitive components in hydraulic circuits. Install the series upstream of specific components or directly after the pressure pump in smaller systems to minimize risk of failure and costly system downtime. Ideal for use on a power unit pump discharge filter or pilot filter directly in front of valves and actuators. The HPK05 is made of ductile iron and steel to provide maximum strength and reliability. The HPK05 filters contain Donaldson's exclusive DT high-performance media for industry leading performance.

Beta Rating

- Performance to $\beta_{<4(\mu)}=1000$

Porting Size Options

- 2" SAE 4-Bolt Flange Code 62

Replacement Filter Lengths

- 23.79"/604.3mm

Standard Bypass Ratings

- 87 psi / 600 kPa / 6.0 bar with reverse-flow check valve
- No Bypass

Assembly Weight

- 123.5 lbs / 56.0 kg

Operating Temperatures

- -04°F to 140°F / -20°C to 60°C

Filter Collapse Ratings

- 450 psi / 3102 kPa / 31.0 bar (standard)
- 3000 psi / 20,700 kPa / 206.9 bar (high collapse)

HPK05 Specification Illustrations

ASSEMBLY - SIDE VIEW

All dimensions are shown in millimeters [inches].

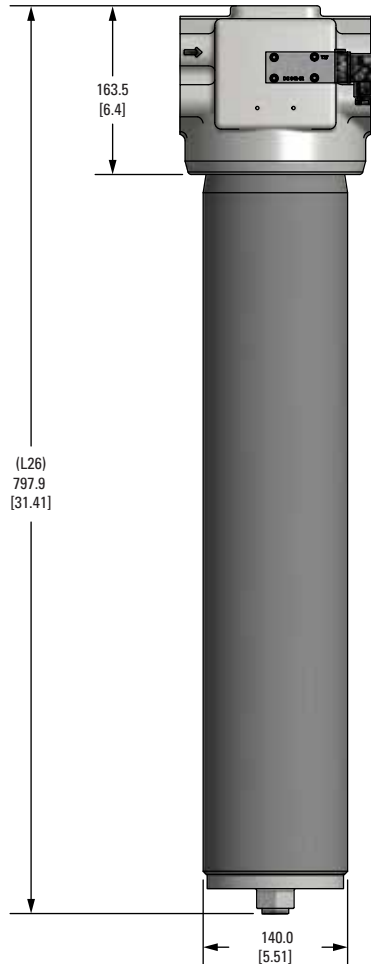

HEAD - TOP VIEW

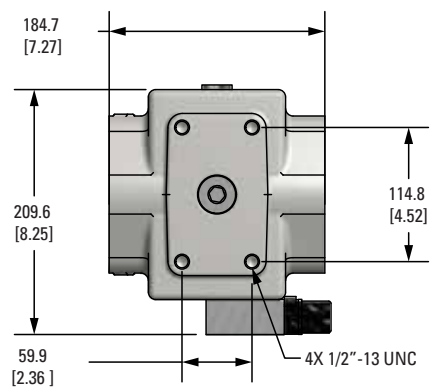



HPK05

Max Flow: 200 gpm (757 lpm)



HPK05 Components

Filter Choices

Media Type	$\beta_{x(c)} = 1000$	Length		Part No.	Comments
	Rating based on ISO 16889	in	mm		
DT Synthetic	8 μm	23.8	658	P585189	87 psid / 6 bar bypass valve
	14 μm	23.8	658	P585190	87 psid / 6 bar bypass valve
	25 μm	23.8	658	P585191	87 psid / 6 bar bypass valve
	8 μm	23.8	658	P585192	High collapse
	14 μm	23.8	658	P585193	High collapse
	25 μm	23.8	658	P585194	High collapse

Filter Notes: All Donaldson DT filters utilize glass fiber media with an acrylic-based resin system for the ultimate in chemical compatibility. All Donaldson DT filters are potted with acrylic-based adhesives. Standard collapse DT designs are double wire-backed using acrylic-coated steel mesh for maximum pleat support and dirt capacity. High collapse designs are double wire-backed using stainless steel mesh. High collapse designs are also potted into machined aluminum endcaps for greater filter integrity in critical applications. Fluorocarbon seals are standard on all Donaldson DT filters.

Assembly Choices

Port Size	Bypass Rating	Indicator Style/ Location ¹	Assembly Number
2" SAE 4-Bolt Flange (Code 62)	Bypass valve is in filter element	Port machined and plugged	K052124

Indicator Choices (Replacement Indicator Only)

Part No.	Description
P585186	Electrical switch only (DIN Connection)
P585187	Visual indicator with electric switch
P585188	Visual Indicator
Service Parts	
X230019	Fluorocarbon Seal Kit

Performance Data

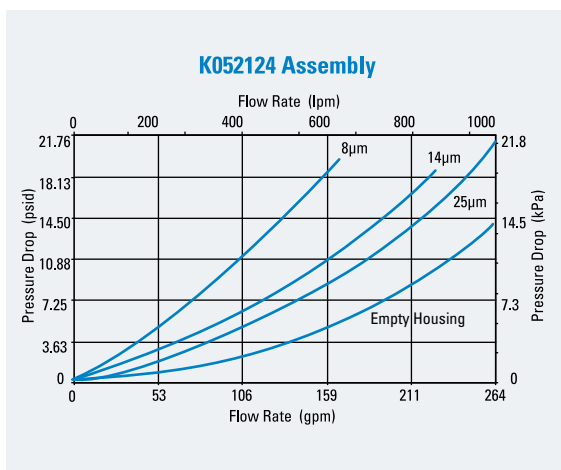



DT Hydraulic Cartridges

Using Donaldson synthetic media technology, DT filters extend filter life, allow higher initial cleanliness and provide superior system protection.



Coupler **P167324** available to connect filters.

Section Index

Donaldson Blue Hydraulic Cartridges	155
DT Synthetic Cartridges	156
How it Works	156
Popular DT Filters.....	157
Pall SRT Replacement Cartridges.....	158

Donaldson Blue™ Hydraulic Cartridges

The Donaldson Company has been releasing and supporting Donaldson Blue premium product in our Air, Clean Solutions and Liquid filtration product categories. Now, we're extending the same high quality coverage to our hydraulic offering with the first ever, Donaldson Blue Hydraulic filters.

Donaldson Blue Hydraulic filters deliver:

- Superior efficiency
- Longer filter life
- Reduced flow restriction

Donaldson Blue hydraulic filters deliver better system protection and performance.

Cross Reference

Donaldson Blue	Schroeder®	Hydac®	Pall®	Parker®
DBH6018	KZ5	2060529	HC9700FKN9H or CN9H	HF4L10VQ
DBH6019	KZ10	2060530	HC9700FKS9H or CS9H	HF4L15VQ
DBH6020	KKZ5	2060431	HC9700FKN18H or CN18H	932678Q
DBH6138	KKZ10	2060432	HC9700FKS18H or CS18H	932679Q
DBH6139	27KZ5	2065004	HC9700FKN27H or CN27H	933487Q
DBH6140	27KZ10	2065005	HC9700FKS27H or CS27H	933488Q

Schroeder® is a registered trademark of Schroeder Industries, LLC. Hydac® is a registered trademark of Hydac Technology GmbH. Pall® is a registered trademark of Pall Corporation. Parker® /Parker-Hannifin is a registered trademark of Parker Intangibles, LLC.



DT synthetic filters provide superior hydraulic system protection.

Premium Uptime Protection

Every hydraulic system has suspended particles in its fluid. Contaminants grind and wear at the surface of moving parts, introducing even more particles into the system. These contaminants cause more than 70% of all hydraulic system downtime.

Donaldson DT synthetic cartridge filters provide better protection from the particles and contaminants that reduce the effectiveness of lubricant and hydraulic fluid. Using Donaldson Synteq™ media technology, these filters extend filter life, allow higher initial cleanliness and provide superior system protection.

Donaldson DT filters are ideally suited for a variety of demanding applications, including:

- heavy-duty mobile equipment
- in-plant hydraulics
- transmissions
- bearing lube oil systems

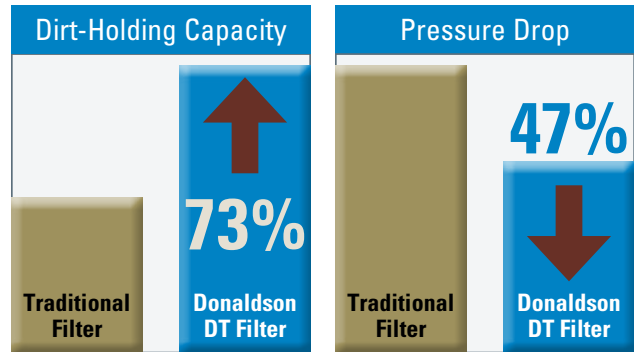

See How Donaldson DT Filters Work

DT cartridge filters feature an advanced pleat pack design that provides higher initial cleanliness and dirt holding capacity.

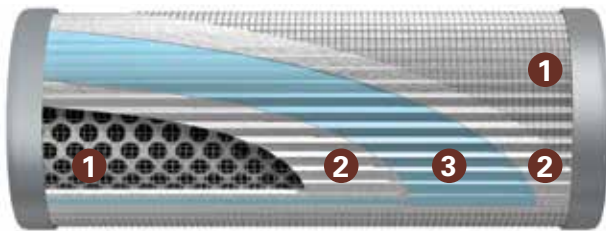

1 Acrylic-Coated Steel Support Mesh (Upstream and Downstream Sides)

- Provides excellent pleat support and spacing, which allows for maximum effective media area
- Protects against media damage during handling and installation

2 Media Support Layers (Upstream and Downstream Sides)

- Optimizes media support
- Protects media during pressure surges

3 Synteq™ Media Technology

Donaldson-developed Synteq synthetic filter media has smooth, rounded fibers for low resistance to fluid flow. Synteq media is ideal for filtering synthetic fluids, water glycols, water/oil emulsions, HWCF (high water content fluids) and petroleum-based fluids.

- High-efficiency media grades with performance to $\beta_{<4(e)} = 1000$ (per ISO 16889)
- Exceptionally low flow resistance
- Consistent performance throughout filter life
- Excellent fluid compatibility



Engineered to fit competitive applications:

DIN* Standard	400, 630, 1000 Series
Fairey Arlon	170, 270, 370
Hydac	0030D, 0500R, 0060D/R, 0075D, 0110D/R, 0140D, 0160D/R, 0240D/R, 0280D, 0330D/R, 0660D/R, 0850R, 0950R, 1300R, 2600R
Pall	2544, 8200, 8300, 8310, 8314, 8800, 8900, 8904, 9020, 9021, 9024, 9100, 9101, 9104, 9400, 9404, 9600, 9601, 9604, 9650, 9651, 9800, 9801, 9804, 9901
Parker	15/40/80 CN, 25P, 31P, 61P, RF2/IL2
Porous Media	LG Series
PTI/Mahle	015/Pi X105, 025/Pi X108, 030/Pi X111, 050/Pi X115, 080/Pi X130, 120/Pi X145, PTI RP83
Schroeder	A, K, KK, KKK, N, NN, V

For a complete list of replacement part numbers, visit shop.donaldson.com. *DIN - Deutsches Institut für Normung E.V., the German Institute for Standardization



Donaldson	Description	Pall	Hydac	Parker	Schroeder
P566658	DT-0110-D-5UM	HC2206FKP6H or Z	0110D003BN4HC	PR3085	SBF-0110D-Z3B or V
P566659	DT-0110-D-8UM	HC2206FKN6H or Z	0110D005BN4HC	PR3086	SBF-0110D-Z5B or V
P566660	DT-0110-D-14UM	HC2206FKS6H or Z	0110D010BN4HC	PR3087	SBF-0110D-Z10B or V
P566965	DT-0110-R-5UM	HC2196FKP6H or Z	0110R003BN4HC	PR3256	SBF0110RZ3B or V
P566966	DT-0110-R-8UM	HC2196FKN6H or Z	0110R005BN4HC	PR3257	SBF0110RZ5B or V
P566967	DT-0110-R-14UM	HC2196FKS6H or Z	0110R010BN4HC	PR3258	SBF0110RZ10B or V
P566968	DT-0110-R-25UM	HC2196FKT6H or Z	0110R020BN4HC	PR3259	SBF0110RZ25B or V
P566666	DT-0160-D-5UM	HC2216FKP4H or Z	0160D003BN4HC	PR3114	SBF-0160D-Z3B or V
P566667	DT-0160-D-8UM	HC2216FKN4H or Z	0160D005BN4HC	PR3115	SBF-0160D-Z5B or V
P566668	DT-0160-D-14UM	HC2216FKS4H or Z	0160D010BN4HC	PR3116	SBF-0160D-Z10B or V
P566969	DT-0160-R-5UM	HC2226FKP4H or Z	0160R003BN4HC	PR3273	SBF0160RZ3B or V
P566970	DT-0160-R-8UM	HC2226FKN4H or Z	0160R005BN4HC	PR3274	SBF0160RZ5B or V
P566971	DT-0160-R-14UM	HC2226FKS4H or Z	0160R010BN4HC	PR3275	SBF0160RZ10B or V
P566972	DT-0160-R-25UM	HC2226FKT4H or Z	0160R020BN4HC	PR3276	SBF0160RZ25B or V
P566670	DT-0240-D-5UM	HC2216FKP6H or Z	0240D003BN4HC	PR3143	SBF-0240D-Z3B or V
P566671	DT-0240-D-8UM	HC2216FKN6H or Z	0240D005BN4HC	PR3144	SBF-0240D-Z5B or V
P566672	DT-0240-D-14UM	HC2216FKS6H or Z	0240D010BN4HC	PR3145	SBF-0240D-Z10B or V
P566977	DT-0240-R-5UM	HC2226FKP6H or Z	0240R003BN4HC	PR3290	SBF0240RZ3B or V
P566978	DT-0240-R-8UM	HC2226FKN6H or Z	0240R005BN4HC	PR3291	SBF0240RZ5B or V
P566979	DT-0240-R-14UM	HC2226FKS6H or Z	0240R010BN4HC	PR3292	SBF0240RZ10B or V
P566980	DT-0240-R-25UM	HC2226FKT6H or Z	0240R020BN4HC	PR3293	SBF0240RZ25B or V
P566674	DT-0280-D-5UM	NA	0280D003BN4HC	NA	SBF-0280D-Z3B OR V
P566675	DT-0280-D-8UM	NA	0280D005BN4HC	NA	SBF-0280D-Z5B OR V
P566676	DT-0280-D-14UM	NA	0280D010BN4HC	NA	SBF-0280D-Z10B OR V
P566677	DT-0280-D-25UM	NA	0280D020BN4HC	NA	SBF-0280D-Z25B OR V
P566678	DT-0330-D-5UM	HC2233FKP6H or Z	0330D003BN4HC	PR3172	SBF-0330D-Z3B or V
P566679	DT-0330-D-8UM	HC2233FKN6H or Z	0330D005BN4HC	PR3173	SBF-0330D-Z5B or V
P566680	DT-0330-D-14UM	HC2233FKS6H or Z	0330D010BN4HC	PR3174	SBF-0330D-Z10B or V
P566681	DT-0330-D-25UM	HC2233FKT6H or Z	0330D020BN4HC	PR3175	SBF-0330D-Z25B or V
P566981	DT-0330-R-5UM	HC2246FKP6H or Z	0330R003BN4HC	PR3307	SBF0330RZ3B or V
P566982	DT-0330-R-8UM	HC2246FKN6H or Z	0330R005BN4HC	PR3308	SBF0330RZ5B or V
P566983	DT-0330-R-14UM	HC2246FKS6H or Z	0330R010BN4HC	PR3309	SBF0330RZ10B or V
P566984	DT-0330-R-25UM	HC2246FKT6H or Z	0330R020BN4HC	PR3310	SBF0330RZ25B or V
P566195	DT-9020-4-5UM	HC9020FKP4H or Z	H9020-4-003BN4HC	932610Q	SBF-9020-4Z3B or V
P566196	DT-9020-4-8UM	HC9020FKN4H or Z	H9020-4-005BN4HC	933239Q	SBF-9020-4Z5B or V
P566197	DT-9020-4-14UM	HC9020FKS4H or Z	H9020-4-010BN4HC	925580Q	SBF-9020-4Z10B or V
P566200	DT-9020-8-5UM	HC9020FKP8H or Z	H9020-8-003BN4HC	925602Q	SBF-9020-8Z3B or V
P566201	DT-9020-8-8UM	HC9020FKN8H or Z	H9020-8-005BN4HC	933246Q	SBF-9020-8Z5B or V
P566202	DT-9020-8-14UM	HC9020FKS8H or Z	H9020-8-010BN4HC	925600Q	SBF-9020-8Z10B or V
P566210	DT-9600-8-5UM	HC9600FKP8H or Z	H9600-8-003BN4HC	926697Q	SBF-9600-8Z3B or V
P566212	DT-9600-8-14UM	HC9600FKS8H or Z	H9600-8-010BN4HC	926837Q	SBF-9600-8Z10B or V
P566215	DT-9600-13-5UM	HC9600FKP13H or Z	H9600-13-003BN4HC	926698Q	SBF-9600-13Z3B or V
P566216	DT-9600-13-8UM	HC9600FKN13H or Z	H9600-13-006BN4HC	926845Q	SBF-9600-13Z5B or V
P566217	DT-9600-13-14UM	HC9600FKS13H or Z	H9600-13-010BN4HC	926839Q	SBF-9600-13Z10B or V
P566220	DT-9600-16-5UM	HC9600FKP16H or Z	H9600-16-003BN4HC	926699Q	SBF-9600-16Z3B or V
P566221	DT-9600-16-8UM	HC9600FKN16H or Z	H9600-16-005BN4HC	926890Q	SBF-9600-16Z5B or V
P566222	DT-9600-16-14UM	HC9600FKS16H or Z	H9600-16-010BN4HC	926888Q	SBF-9600-16Z10B or V
P566373	DT-9604-8-5UM	HC9604FKP8H or Z	NA	NA	SBF-9604-8Z3B OR V
P566374	DT-9604-8-8UM	HC9604FKN8H or Z	NA	NA	SBF-9604-8Z5B OR V
P566375	DT-9604-8-14UM	HC9604FKS8H or Z	NA	NA	SBF-9604-16Z10B OR V
P566378	DT-9604-13-5UM	HC9604FKP13H or Z	NA	NA	SBF-960413Z3B OR V
P566379	DT-9604-13-8UM	HC9604FKN13H or Z	NA	NA	SBF-9604-13Z5B OR V
P566380	DT-9604-13-14UM	HC9604FKS13H or Z	NA	NA	SBF-9604-13Z10B OR V
P566383	DT-9604-16-5UM	HC9604FKP16H or Z	NA	NA	SBF-9604-16Z3B OR V
P566384	DT-9604-16-8UM	HC9604FKN16H or Z	NA	NA	SBF-9604-16Z5B OR V
P566385	DT-9604-16-14UM	HC9604FKS16H or Z	NA	NA	SBF-9604-16Z10B OR V
P566270	DT-HF4-9-5UM	HC9700FKP9H or Z	HK003BN4HC	HF4L3VQ	KZ3
P566271	DT-HF4-9-8UM	HC9700FKN9H or Z	HK005BN4HC	HF4L10VQ	KZ5
P566272	DT-HF4-9-14UM	HC9700FKS9H or Z	HK010BN4HC	HF4L15VQ	KZ10
P566274	DT-HF4-18-5UM	HC9700FKP18H or Z	H2K003BN4HC	932677Q	KKZ3
P566275	DT-HF4-18-8UM	HC9700FKN18H or Z	H2K005BN4HC	932678Q	KKZ5
P566276	DT-HF4-18-14UM	HC9700FKS18H or Z	H2K010BN4HC	932679Q	KKZ10



Pall® Athalon™ Replacement Filters

Cartridge Replacements for Pall 210, 310 and 610 Housings



Pall Athalon Replacement Filters

Replacement Filters for Pall® Athalon™

The Donaldson hydraulic product line has expanded to include replacement cartridges for Pall Athalon style housings in the 210, 310 and 610 series. Donaldson cartridge filters provide protection from particles and contaminants that reduce the effectiveness of lubricant and hydraulic fluid. Using Donaldson DT High-Performance synthetic media technology, these filters have long life and provide excellent system protection.

Better by Design

These high-performance cartridge filters feature an advanced pleat pack design that provides high initial cleanliness and dirt holding capacity.

- Double wire backed with an acrylic-coated steel mesh for excellent pleat support and spacing, which allows for maximum media area and excellent protection during operating pressure surges
- Utilizes glass fiber high performance synthetic media with an acrylic-based resin system and is potted with acrylic-based adhesives
- Fluorocarbon O-ring seals for excellent compatibility with a wide range of fluid types

Length	Beta _{x(c)} = 1000 Rating	Donaldson Part No.	Competitive Cross Reference		
			Pall	Hydac	Schroeder
210 Series					
4" (102mm)	< 4 µm	P580592	UE210AZ04Z	—	—
	5 µm	P580593	UE210AP04Z	—	SBFUE2104Z3V
	8 µm	P580594	UE210AN04Z	—	SBFUE2104Z5V
	12 µm	P580595	UE210AS04Z	—	SBFUE2104Z10V
	25 µm	P580596	UE210AT04Z	—	SBFUE2104Z25V
8" (203mm)	< 4 µm	P580597	UE210AZ08Z	—	—
	5 µm	P580598	UE210AP08Z	—	SBFUE2108Z3V
	8 µm	P580599	UE210AN08Z	—	SBFUE2108Z5V
	12 µm	P580600	UE210AS08Z	—	SBFUE2108Z10V
	25 µm	P580601	UE210AT08Z	—	SBFUE2108Z25V
13" (330mm)	< 4 µm	P580602	UE210AZ13Z	—	—
	5 µm	P580603	UE210AP13Z	—	SBFUE21013Z3V
	8 µm	P580604	UE210AN13Z	—	SBFUE21013Z5V
	12 µm	P580605	UE210AS13Z	—	SBFUE21013Z10V
	25 µm	P580606	UE210AT13Z	—	SBFUE21013Z25V
20" (508mm)	< 4 µm	P580607	UE210AZ20Z	—	—
	5 µm	P580608	UE210AP20Z	—	SBFUE21020Z3V
	8 µm	P580609	UE210AN20Z	—	SBFUE21020Z5V
	12 µm	P580610	UE210AS20Z	—	SBFUE21020Z10V
	25 µm	P580611	UE210AT20Z	—	SBFUE21020Z25V
310 Series					
8" (203mm)	< 4 µm	P580612	UE310AZ08Z	—	—
	5 µm	P580613	UE310AP08Z	—	SBFUE3108Z3V
	8 µm	P580614	UE310AN08Z	—	SBFUE3108Z5V
	12 µm	P580615	UE310AS08Z	—	SBFUE3108Z10V
	25 µm	P580616	UE310AT08Z	—	SBFUE3108Z25V
13" (330mm)	< 4 µm	P580617	UE310AZ13Z	—	—
	5 µm	P580618	UE310AP13Z	—	SBFUE31013Z3V
	8 µm	P580619	UE310AN13Z	—	SBFUE31013Z5V
	12 µm	P580620	UE310AS13Z	—	SBFUE31013Z10V
	25 µm	P580621	UE310AT13Z	—	SBFUE31013Z25V
20" (508mm)	< 4 µm	P580622	UE310AZ20Z	—	—
	5 µm	P580623	UE310AP20Z	—	SBFUE31020Z3V
	8 µm	P580624	UE310AN20Z	—	SBFUE31020Z5V
	12 µm	P580625	UE310AS20Z	—	SBFUE31020Z10V
	25 µm	P580626	UE310AT20Z	—	SBFUE31020Z25V
40" (1016mm)	< 4 µm	P580627	UE310AZ40Z	—	—
	5 µm	P580628	UE310AP40Z	—	SBFUE31040Z3V
	8 µm	P580629	UE310AN40Z	—	SBFUE31040Z5V
	12 µm	P580630	UE310AS40Z	—	SBFUE31040Z10V
	25 µm	P580631	UE310AT40Z	—	SBFUE31040Z25V
610 Series					
20" (508mm)	< 4 µm	P573125	UE610AZ20Z	1.22.20D03RT	—
	5 µm	P573126	UE610AP20Z	1.22.20D05RT	SBFUE61020Z3V
	8 µm	P573127	UE610AN20Z	1.22.20D07RT	SBFUE61020Z5V
	12 µm	P573128	UE610AS20Z	1.22.20D12RT	SBFUE61020Z10V
	25 µm	P573129	UE610AT20Z	1.22.20D20RT	SBFUE61020Z25V
40" (1016mm)	< 4 µm	P573130	UE610AZ40Z	1.22.40D03RT	—
	5 µm	P573131	UE610AP40Z	1.22.40D05RT	SBFUE61040Z3V
	8 µm	P573132	UE610AN40Z	1.22.40D07RT	SBFUE61040Z5V
	12 µm	P573133	UE610AS40Z	1.22.40D12RT	SBFUE61040Z10V
	25 µm	P573134	UE610AT40Z	1.22.40D20RT	SBFUE61040Z25V

Pall® and Athalon® are registered trademarks of Pall Corporation.



Donaldson replacement filters for Pall Ultipleat SRT 219, 319 and 619 style housings provide protection from particles and contaminants that reduce the effectiveness of lubricant and hydraulic fluid. Using Donaldson DT synthetic media technology, these filters have long life and provide excellent system protection.

These filters feature an advanced pleat pack design that provides high initial cleanliness and efficient dirt holding capacity.

Double wire backed with an acrylic-coated steel mesh for excellent pleat support and spacing, which allows for maximum media area and excellent protection during operating pressure surges

Utilizes glass fiber DT synthetic media with an acrylic-based resin system and is potted with acrylic-based adhesives fluorocarbon O-Ring seals for excellent compatibility with a wide range of fluid types.

Electrostatic Discharge (ESD) Reduction

Donaldson SRT replacement filters are designed to resist charge generation and reduce the occurrence of electrostatic discharges induced by the flow of fluids through the filter media – a known industry problem which can result in damage to the filter and degraded performance.

Utilizing DT Synthetic Media Technology

Donaldson invented DT synthetic filter media has smooth, rounded fibers for low resistance to fluid flow. Synteq media is ideal for filtering synthetic fluids, water glycols, water/oil emulsions, petroleum-based and high water content fluids (HWCF).

Pall® and Ultipleat® are registered trademarks of Pall Corporation.

Length	Beta _{x(c)} = 1000 Rating	Donaldson Part No.	Competitive Cross Reference		
			Pall	Hydac	Schroeder
209 Series					
4" (102mm)	4 µm	P577699	UE209AZ03Z	1.27.03 D 03 RT	SBFUE209-3Z3V
	5 µm	P577700	UE209AP03Z	1.27.03 D 05 RT	SBFUE209-3Z5V
	8 µm	P577701	UE209AN03Z	1.27.03 D 07 RT	SBFUE209-3Z5V
	12 µm	P577702	UE209AS03Z	1.27.03 D 12 RT	SBFUE209-3Z10V
	25 µm	P577703	UE209AT03Z	1.27.03 D 20 RT	SBFUE209-3Z25V
8" (203mm)	4 µm	P577704	UE209AZ07Z	1.27.07 D 03 RT	SBFUE209-7Z3V
	5 µm	P577705	UE209AP07Z	1.27.07 D 05 RT	SBFUE209-7Z5V
	8 µm	P577706	UE209AN07Z	1.27.07 D 07 RT	SBFUE209-7Z5V
	12 µm	P577707	UE209AS07Z	1.27.07 D 12 RT	SBFUE209-7Z10V
	25 µm	P577708	UE209AT07Z	1.27.07 D 20 RT	SBFUE209-7Z25V
219 Series					
4" (102mm)	< 4 µm	P573085	UE219AZ04H or Z	1.28.04 D 03 RT	SBFUE219-4Z3V
	5 µm	P573086	UE219AP04H or Z	1.28.04 D 05 RT	SBFUE219-4Z5V
	8 µm	P573087	UE219AN04H or Z	1.28.04 D 07 RT	—
	12 µm	P573088	UE219AS04H or Z	1.28.04 D 12 RT	SBFUE219-4Z10V
	25 µm	P573089	UE219AT04H or Z	1.28.04 D 20 RT	SBFUE219-4Z25V
8" (203mm)	< 4 µm	P573090	UE219AZ08H or Z	1.28.08 D 03 RT	SBFUE219-8Z3V
	5 µm	P573091	UE219AP08H or Z	1.28.08 D 05 RT	SBFUE219-8Z5V
	8 µm	P573092	UE219AN08H or Z	1.28.08 D 07 RT	—
	12 µm	P573093	UE219AS08H or Z	1.28.08 D 12 RT	SBFUE219-8Z10V
	25 µm	P573094	UE219AT08H or Z	1.28.08 D 20 RT	SBFUE219-8Z25V
13" (330mm)	< 4 µm	P573095	UE219AZ13H or Z	1.28.13 D 03 RT	SBFUE219-13Z3V
	5 µm	P573096	UE219AP13H or Z	1.28.13 D 05 RT	SBFUE219-13Z5V
	8 µm	P573097	UE219AN13H or Z	1.28.13 D 07 RT	—
	12 µm	P573098	UE219AS13H or Z	1.28.13 D 12 RT	SBFUE219-13Z10V
	25 µm	P573099	UE219AT13H or Z	1.28.13 D 20 RT	SBFUE219-13Z25V
20" (508mm)	< 4 µm	P573100	UE219AZ20H or Z	1.28.20 D 03 RT	SBFUE219-20Z3V
	5 µm	P573101	UE219AP20H or Z	1.28.20 D 05 RT	SBFUE219-20Z5V
	8 µm	P573102	UE219AN20H or Z	1.28.20 D 07 RT	—
	12 µm	P573103	UE219AS20H or Z	1.28.20 D 12 RT	SBFUE219-20Z10V
	25 µm	P573104	UE219AT20H or Z	1.28.20 D 20 RT	SBFUE219-20Z25V
299 Series					
4" (102mm)	2 µm	P577715	UE299AZ04Z	1.24.04 D 03 RT	—
	5 µm	P577716	UE299AP04Z	1.24.04 D 05 RT	—
	8 µm	P577717	UE299AN04Z	1.24.04 D 07 RT	—
	12 µm	P577718	UE299AS04Z	1.24.04 D 12 RT	—
	25 µm	P577719	UE299AT04Z	1.24.04 D 20 RT	—
8" (203mm)	2 µm	P577720	UE299AZ08Z	1.24.08 D 03 RT	—
	5 µm	P577721	UE299AP08Z	1.24.08 D 05 RT	—
	8 µm	P577722	UE299AN08Z	1.24.08 D 07 RT	—
	12 µm	P577723	UE299AS08Z	1.24.08 D 12 RT	—
	25 µm	P577724	UE299AT08Z	1.24.08 D 20 RT	—
13" (330mm)	2 µm	P577725	UE299AZ13Z	1.24.13 D 03 RT	—
	5 µm	P577726	UE299AP13Z	1.24.13 D 05 RT	—
	8 µm	P577727	UE299AN13Z	1.24.13 D 07 RT	—
	12 µm	P577728	UE299AS13Z	1.24.13 D 12 RT	—
	25 µm	P577729	UE299AT13Z	1.24.13 D 22 RT	—
20" (508mm)	2 µm	P577730	UE299AZ20Z	1.24.20 D 03 RT	—
	5 µm	P577731	UE299AP20Z	1.24.20 D 05 RT	—
	8 µm	P577732	UE299AN20Z	1.24.20 D 07 RT	—
	12 µm	P577733	UE299AS20Z	1.24.20 D 12 RT	—
	25 µm	P577734	UE299AT20Z	1.24.20 D 22 RT	—



Pall® Ultipleat® SRT Replacement Filters

Cartridge Replacements for SRT 319 & 619 Housings



CARTRIDGE FILTERS

Length	Beta _{x(c)} = 1000 Rating	Donaldson Part No.	Competitive Cross Reference		
			Pall	Hydac	Schroeder
319 Series					
8" (203mm)	< 4 μm	P573105	UE319AZ08H or Z	1297074 or 1.21.08D03RT	SBFUE319-8Z3V
	5 μm	P573106	UE319AP08H or Z	1296464 or 1.21.08D05RT	SBFUE319-8Z5V
	8 μm	P573107	UE319AN08H or Z	1296465 or 1.21.08D07RT	—
	12 μm	P573108	UE319AS08H or Z	1297075 or 1.21.08D12RT	SBFUE319-8Z10V
	25 μm	P573109	UE319AT08H or Z	1.21.08 D 20 RT	SBFUE319-8Z25V
13" (330mm)	< 4 μm	P573110	UE319AZ13H or Z	1297076 or 1.21.13D03RT	SBFUE319-13Z3V
	5 μm	P573111	UE319AP13H or Z	1296466 or 1.21.13D05RT	SBFUE319-13Z5V
	8 μm	P573112	UE319AN13H or Z	1296467 or 1.21.13D07RT	—
	12 μm	P573113	UE319AS13H or Z	1297077 or 1.21.13D12RT	SBFUE319-13Z10V
	25 μm	P573114	UE319AT13H or Z	1.21.13 D 20 RT	SBFUE319-13Z25V
20" (508mm)	< 4 μm	P573115	UE319AZ20H or Z	1297078 or 1.21.20D03RT	SBFUE319-20Z3V
	5 μm	P573116	UE319AP20H or Z	1296468 or 1.21.20D05RT	SBFUE319-20Z5V
	8 μm	P573117	UE319AN20H or Z	1296469 or 1.21.20D07RT	—
	12 μm	P573118	UE319AS20H or Z	1297079 or 1.21.20D12RT	SBFUE319-20Z10V
	25 μm	P573119	UE319AT20H or Z	1.21.20 D 20 RT	SBFUE319-20Z25V
40" (1016mm)	< 4 μm	P573120	UE319AZ40H or Z	1297080 or 1.21.40D03RT	SBFUE319-40Z3V
	5 μm	P573121	UE319AP40H or Z	1296665 or 1.21.40D05RT	SBFUE319-40Z5V
	8 μm	P573122	UE319AN40H or Z	1296666 or 1.21.40D07RT	—
	12 μm	P573123	UE319AS40H or Z	1297083 or 1.21.40D12RT	SBFUE319-40Z10V
	25 μm	P573124	UE319AT40H or Z	1.21.40 D 20 RT	SBFUE319-40Z25V
619 Series					
20" (508mm)	< 4 μm	P573125	UE619AZ20H or Z	1297084 or 1.22.20D03RT	SBFUE619-20Z3V
	5 μm	P573126	UE619AP20H or Z	1296470 or 1.22.20D05RT	SBFUE619-20Z5V
	8 μm	P573127	UE619AN20H or Z	1296471 or 1.22.20D07RT	—
	12 μm	P573128	UE619AS20H or Z	1297085 or 1.22.20D12RT	SBFUE619-20Z10V
	25 μm	P573129	UE619AT20H or Z	1.22.20 D 20 RT	SBFUE619-20Z25V
40" (1016mm)	< 4 μm	P573130	UE619AZ40H or Z	1297086 or 1.22.40D03RT	SBFUE619-40Z3V
	5 μm	P573131	UE619AP40H or Z	1296472 or 1.22.40D05RT	SBFUE619-40Z5V
	8 μm	P573132	UE619AN40H or Z	1296473 or 1.22.40D07RT	—
	12 μm	P573133	UE619AS40H or Z	1297087 or 1.22.40D12RT	SBFUE619-40Z10V
	25 μm	P573134	UE619AT40H or Z	1.22.40 D 20 RT	SBFUE619-40Z25V



Accessories

Donaldson offers an extensive line of accessories for hydraulic circuits, lines and reservoirs that will help you maintain proper ISO cleanliness levels.



T.R.A.P.™ Breather Technology

(Thermally Reactive Advanced Protection)

T.R.A.P. breathers provide fast-acting protection against airborne moisture and particulate contamination. It stops solid particulate down to 3 μm at 97% efficiency as well as prevents moisture from entering the reservoir. Water-holding capacity is regenerated with every oil return phase for long service life. Its self-regenerating capability enables extended life.

Section Index

Filter Service Indicators

Visual Service Indicator Kits.....	162
Visual / Electrical Service Indicator Kits	162
Electrical Service Indicators	163
Visual / Electrical Indicators.....	164
Visual Pressure Gauges.....	164

In-Line Accessories

Pressure Gauges.....	167
Test Points.....	170
Valves.....	174
Flanges.....	177

Reservoir Accessories

Strainers	184
Diffusers	187
Breathers.....	188
T.R.A.P.™ Breathers	189
Reservoir Air Dryer	202
Sight Glasses	206
Level Gauges	208

Visual Service Indicator Kits

Visual Service Indicator Kit Choices

Part No.	Use with Bypass Valve Pressure of:	Description	Where Used
P569632	50 psi / 3.5 bar	35 psi/2.4 bar indicator kit* auto reset pop-out button	HPK02, HPK03, HPK04, HPK05
P569633	90 psi / 6.2 bar	70 psi/4.8 bar indicator kit* auto reset pop-out button	HPK02, HPK03, HPK04, HPK05
P567988	50 psi / 3.5 bar	35 psi/2.4 bar indicator kit* auto reset pop-out button with thermal lockout and surge control	HPK02, HPK03, HPK04, HPK05
P567989	90 psi / 6.2 bar	70 psi/4.8 bar indicator kit* auto reset pop-out button with thermal lockout and surge control	HPK02, HPK03, HPK04, HPK05

* Note: Above kits include indicator and P573495 mounting block.

Visual (Mechanical) Indicators (with auto reset pop-out button)

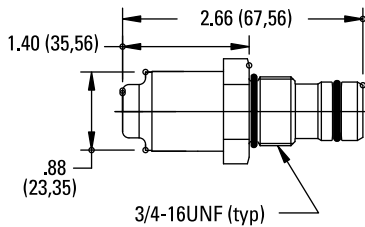

Visual/Electrical Service Indicator Kit Choices

Part No.	Use with Bypass Valve Pressure of:	Description	Where Used
P569634	50 psi / 3.5 bar	35 psi/2.4 bar indicator kit* Hirschmann receptacle 115 VAC/28 VDC, 2 amps	HPK02, HPK03, HPK04, HPK05
P569635	90 psi / 6.2 bar	70 psi/4.8 bar indicator kit* Hirschmann receptacle 115 VAC/28 VDC, 2 amps	HPK02, HPK03, HPK04, HPK05
P567986	50 psi / 3.5 bar	35 psi/2.4 bar indicator kit* with thermal lockout and surge control, Hirschmann receptacle, 115 VAC/28 VDC, 2 amps, 4 pin DIN 43650	HPK02, HPK03, HPK04, HPK05
P567987	90 psi / 6.2 bar	70 psi/4.8 bar indicator kit* with thermal lockout and surge control, Hirschmann receptacle, 115 VAC/28 VDC, 2 amps, 4 pin DIN 43650	HPK02, HPK03, HPK04, HPK05

* Note: Above kits include indicator and P573495 mounting block.

AC/DC Electrical Indicators (with aluminum electrical housing)

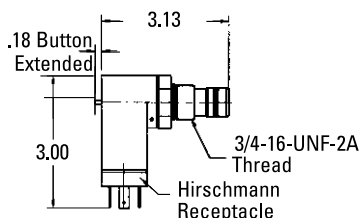

Electrical Service Indicators

Electrical Service Indicator Choices

All electric models have a maximum operating temperature of 250°F/ 114°C.

Part No.	Use with Bypass Valve Pressure of:	Description	Where Used	Illustration
P162400	25 psi/ 172 kPa	DC/single post. Normally open.	HBK04, HBK05, HMK04/24, HMK05/25	Style A
P163601	15 psi/ 103 kPa	DC/single post. Normally open.	HBK04, HBK05, HMK04/24, HMK05/25	Style A
P163839	25 psi/ 172 kPa	DC/single post. Normally closed.	HBK04, HBK05, HMK04/24, HMK05/25	Style A
P574719	50 psi/ 345 kPa	DC/single post. Normally open.	HMK03, HMK04/24, HMK05/25, FPK04	Style A
P574967	50 psi/ 276 kPa	DC 2-wire. Normally closed. Gold contacts. Microprocessor compatible.	HBK05, HMK03, HMK04/24, HMK05/25, FLK90/110/125, FPK04	Style E
P574968	50 psi/ 345 kPa	DC 2-wire. Packard Weatherpack connector. Normally open.	HMK03, HMK04/24, HMK05/25, FLK90/110/125, FPK04	Style B
P171143	25 psi/ 172 kPa	DC 2-wire. Cannon connector. Normally open.	HBK04, HBK05, HMK03, HMK04/24, HMK05/25	Style B
P171966	22 psi/ 150 kPa	AC/DC. 0.5A resistive, 0.2A inductive. Normally open.	FIK	at right
P575549	50 psi/ 345 kPa	DC 3-wire. Gold alloy contacts. Micro-processor compatible. White: normally open; Red: normally closed; Black: common.	HMK04/24, HMK05/25	Style F
P173944	25 psi/ 172 kPa	AC/DC 3-wire. Silver alloy contacts. White: normally open; Red: normally closed; Black: common.	HBK04, HBK05, HMK03, HMK04/24, HMK05/25	Style C
P174396	50 psi/ 345 kPa	AC/DC 3-wire. Silver alloy contacts. White: normally open; Red: normally closed; Black: common.	HMK03, HMK04/24, HMK05/25	Style C
P761056	87 psi/ 592 kPa	AC/DC Normally open or closed. 30 VAC or 30 VDC max. 0.5A resistive, 0.2A inductive.	FPK02	see FPK02 section
P563978	15 psi/103.4 kPa or 25 psi / 172.5 kPa	Return indicator, field adj.* or No Bypass	SP15/25, SP50/60, SP80/90, SP100/120, TT15/30/60	at right

* NOT PRESET: Setting adjustable for desired application

Style A

P162400
P163601
P163839
P574719

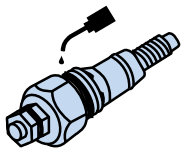

Style B

P574968
P171143

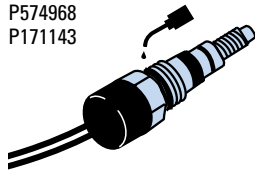

Styles C & F

P173944
P174396
P575549

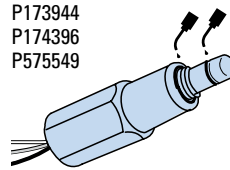

Style E

P574967

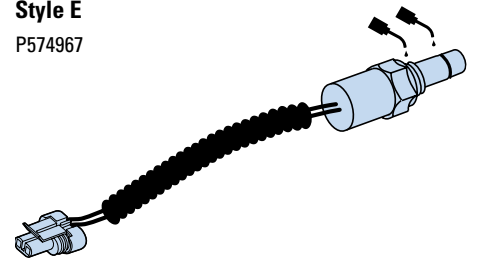

P563978

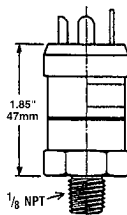
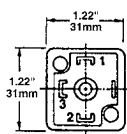

#1 Common; #2 Normally Closed; #3 Normally Open

Instructions

1. Remove DIN adaptor
2. Remove small brass screw
3. Using 1/8" allen wrench adjust clockwise to increase set point/counter-clockwise to decrease set point
4. NO / NC

Adjustment screw located in center of electric prongs

Electric ΔP indicator

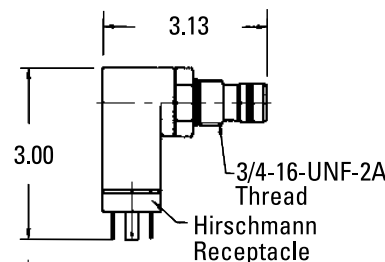

Electric ΔP indicator with pop-up visual button and manual reset

P171966

P563978



Visual Service Indicators

Visual Service Indicator Choices

All non-electric models have a maximum operating temperature of 180°F/ 82°C.

Part No.	Use with Bypass Valve Pressure of:	Where Used	Illustration
P162642	15 psi/103 kPa	HBK04, HBK05, HMK04/24, HMK05/25	Style D
P162694	5 psi/34 kPa	HBK04, HBK05	Style D (old style)
P162696	25 psi/172 kPa	HBK04, HBK05, HMK04/24, HMK05/25	Style D
P164315	50 psi/345 kPa	HPK02, HPK03, HPK04, HPK05	see HPK02 section
P165965	25 psi/345 kPa	HMK03, HMK04/24, HMK05/25	Style D
P574177	50 psi / 345 kPa	HMK03, HMK04/24	Style D
P166603	50 psi/345 kPa (reverse flow)	HPK04	see HPK04 section
P167580	50 psi/345 kPa	HMK04/24, HMK05/25	Style D
P171958	17 psi/116 kPa	FIK	at left
P171945	72 psi/493 kPa	FPK02	see FPK02 section
P575334	25 psi/172 kPa	HBK05, HMK03, HMK05/25, HNK04/05, HMK04/24, FLK90, FLK110, FLK125	Style H
P575335	50 psi/345 kPa	HBK05, HMK03, HMK05/25, HNK04/05, HMK04/24, FLK90, FLK110, FLK125	Style H

Style D

P162642
P162694
P162696
P165965
P574177
P167580

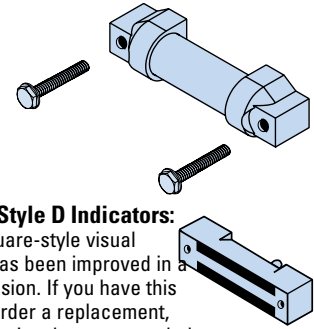

NOTE on Style D Indicators:

Our old square-style visual indicator has been improved in design revision. If you have this style and order a replacement, you will receive the new rounded Style D shown above.

Exception: P162694 is still made per the old style. Bar style visual indicators not for use with phosphate ester applications.

Style H

P575334
P575335

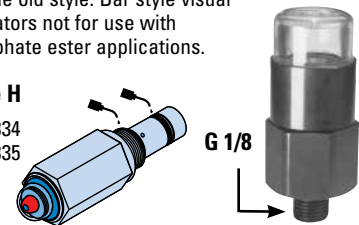

Indicators

Indicator Choices

Indicator Pressure Setting	Connector Style	Part No.	Where Used
Pressure Gauge, 0 - 60 psi Models			
25 psi / 172 kPa	NA	X011059	FIS2
50 psi / 345 kPa	NA	X011075	FIS2
Pressure Gauge, 0 - 200 psi Models			
50 psi / 345 kPa	NA	X011060	FIS2

Indicator Choices

Indicator Pressure Setting	Connector Style	Part No.
Visual Pressure Gauges, 0-60 psi		
25 psi / 172 kPa	NA	X011059
50 psi / 345 kPa	NA	X011075
Visual Pressure Gauges, 0-200 psi		
50 psi / 345 kPa	NA	X011060
Electrical Service Indicator		
25 psi / 172 kPa	Hirschman (DIN 43650)	X220879
25 psi / 172 kPa	3-Wire	X220880
25 psi / 172 kPa	DIN 46248	X220881
50 psid / 345 kPa	Hirschman (DIN 43650)	X220882
50 psid / 345 kPa	3-Wire½	X220883
Adapter		
BSPB Indicator Adapter	1/8" NPT to 1/8" BSPB (G Thread)	P584237

Visual Pressure Gauges

Visual Pressure Gauge Choices

Part No.	Pressure Range	Function
P579714	0 to 100 PSI Numeric Scale	Return
P579715	0 to 100 PSI Color Coded (15 PSI)	Return
P579716	0 to 100 PSI Color Coded (25 PSI)	Return
P579717	0 to -20 Hg	Suction
P563300	0 to 30 PSI Color Coded (15 PSI)	Return

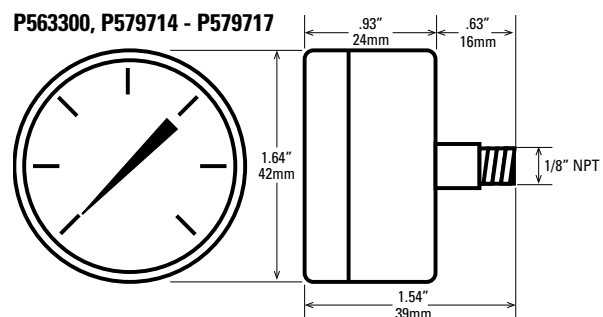
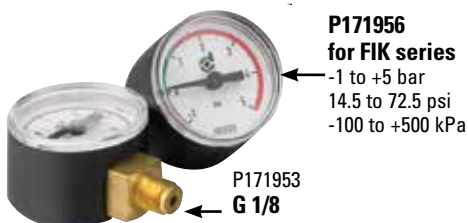

Replacement Indicators (Visual, Electrical and Visual / Electrical)

Replacement Indicator Choices

Part No.	Use with Bypass Valve Pressure of	Connector Style	Seal Material	Thermal Lockout	Surge Control	Where Used
Electrical Indicators						
P572355	15 psid/1.04 bar	Hirschman	Nitrile	No	No	W023, W061
P572359	35 psid/2.41 bar	Hirschman	Nitrile	No	No	W023, W061, W041, W440, W350, W451, W620
P572369	70 psid/4.8 bar	Hirschman	Nitrile	No	No	W041, W440, W350, W451, W620
Visual / Electrical Indicators						
P572323	15 psid/1.04 bar	Hirschman	Nitrile	No	No	W023, W061
P572327	35 psid/2.41 bar	Hirschman	Nitrile	No	No	W023, W061, W041, W440, W350, W451, W620
P572349	35 psid/2.4 bar	3-wire flying leads	Nitrile	No	No	W023, W061, W041, W440, W350, W451, W620
P572384	35 psid/2.4 bar	Hirschman	Nitrile	Yes	Yes	W023, W061, W041, W440, W350, W451, W620
P572385	35 psid/2.4 bar	Brad Harrison	Nitrile	Yes	Yes	W041, W440, W350, W451, W620
P567458	35 psid/2.4 bar	Hirschman	Fluorocarbon	Yes	Yes	W023, W061, W041, W440, W350, W451, W620, HPK02, HPK03, HPK04, HPK05
P567459	70 psid/4.8 bar	Hirschman	Fluorocarbon	Yes	Yes	W440, W350, W451, W620, HPK02, HPK03, HPK04, HPK05
P572320	70 psid/4.8 bar	Hirschman	Nitrile	Yes	Yes	W440, W350, W451, W620
P572387	100 psid/6.89 bar	Hirschman	Nitrile	Yes	Yes	W440, W350, W451
Visual Indicators						
P572345	15 psid/1.04 bar	N/A	Nitrile	No	No	W023, W061
P572347	35 psid/2.41 bar	N/A	Nitrile	No	No	W023, W061, W041, W440, W350, W451, W620
P572348	35 psid/2.41 bar	N/A	Nitrile	Yes	Yes	W023, W061, W041, W440, W350, W451, W620
P567456	35 psid/2.4 bar	N/A	Nitrile	Yes	Yes	W023, W061, W041, W440, W350, W451, W620, HPK02, HPK03, HPK04, HPK05
P572319	70 psid/4.8 bar	N/A	Nitrile	Yes	Yes	W440, W350, W451, W620
P572353	100 psid/6.9 bar	N/A	Nitrile	Yes	No	W440, W350, W451
P572354	100 psid/6.89 bar	N/A	Fluorocarbon	Yes	Yes	W440, W350, W451
P569636	35 psid/2.4 bar	N/A	Fluorocarbon	No	No	HPK02, HPK03, HPK04, HPK05
P569637	70 psid/4.8 bar	N/A	Fluorocarbon	No	No	HPK02, HPK03, HPK04, HPK05

Electrical Schematics

Style A: Single Post DC Indicator
(Maximum: 200 mA DC @ 30 VDC)

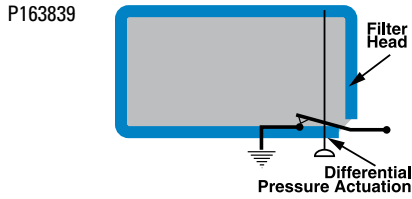

Style B: DC 2-Wire Indicator
(Maximum: 200 mA DC @ 30 VDC)

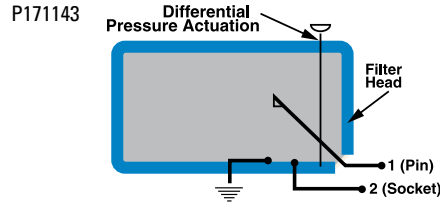

Style C, F: AC/DC 3-Wire Indicator
(Maximums: 2 amps @ 24 VDC or
2 amps @ 110 VAC)

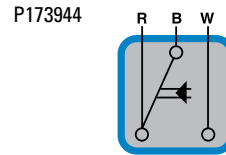

P162400
P163601
P574719

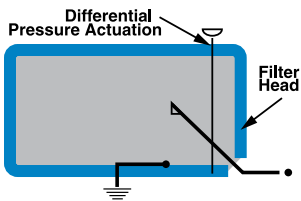

P574968

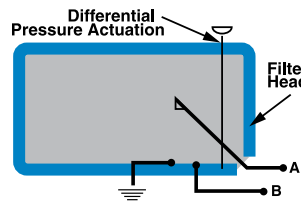

Style E: DC 2-Wire Indicator
(Maximum: 100 mA DC @ 30 VDC)

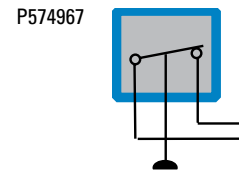

Indicator Switch Schematic Wiring Diagram

All dimensions are shown in millimeters [inches].

Aluminum Electrical Housings

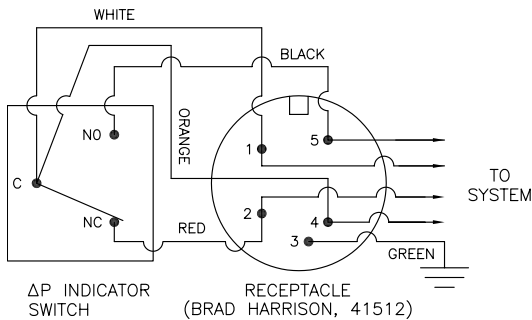

Plastic Electrical Housings

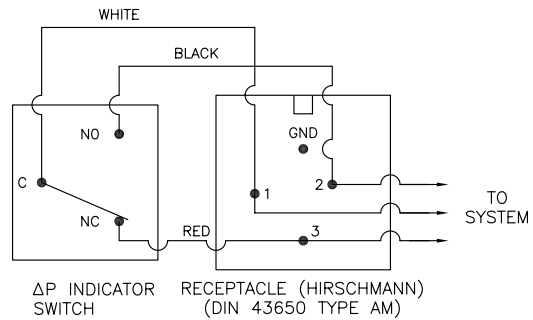
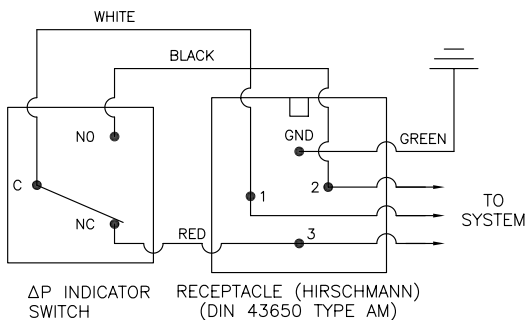
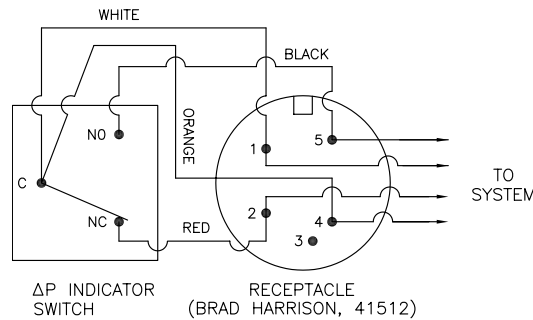

Note: The female plug (connector) is to be furnished by customer.

Note: The female plug (connector) is to be furnished by customer.

Differential Indicators:

Indicators are designed to actuate at approximately 80% of bypass valve cracking pressure. It is recommended that an indicator with a bypass setting of 100 psid is used with a non-bypass housing.

Surge Control:

This optional feature is used to dampen pressure surges or spikes to avoid premature actuation of the indicator. Surge control delays the indicator response.

Thermal Lockout:

The Thermal Lockout prevents premature signaling of a bypass condition created by viscous fluid during cold start-ups. Normal indicator actuation capability is resumed once the operating temperature of the fluid reaches approximately 80° F.



In-Line Accessories

- Pressure gauges for monitoring system pressure
- Hoses and test points for sampling oil and determining ISO cleanliness levels
- Flanges to connect components
- Valves for system control



In-Line Pressure Gauges

Specifications

- Stainless steel (304SS)
- Phosphor bronze bourdon tube
- Acrylic lenses
- Built-in snubber
- Glycerin Filled



Features

Donaldson Pressure Gauge Liquid-filled (PGL) series gauges are mechanical bourdon tube pressure gauges. Each gauge has a glycerin filled stainless steel bezel and case that is robust and will not discolor or rust. The bourdon tube and movement is constructed from brass and bronze alloys. PGL series gauges are easy to install for continuous readings with face diameters of 2½" (63mm) and 4" (100mm).

Operating Temperatures		Dial Sizes			
• 30°F to 160°F (-1°C to 71°C)		• 2½" (63mm) and 4" (100mm)			
Accuracy		Mounting			
• +/- 3% of full scale		• Stem, Panel, Front Flange			
Scale		Thread Type			
• psi	• bar	• 2½" size	• 4"	• ¼" NPT, ¼" SAE, ¼" BSP	• ½" NPT

In-Line Pressure Gauges

Pressure Range Options

PGL-A	30 Hg-20 psi	0-30 in. Hg	0-30 psi	0-60 psi	0-100 psi	0-160 psi	0-300 psi	0-500 psi	0-600 psi	0-1000 psi	0-1500 psi	0-2000 psi	0-3000 psi	0-4000 psi	0-5000/345 psi	0-6000 psi	0-10000 psi
2 1/2" Stem	•	•	•	•	•	•	•	•	•	•	•	•	•	•	•	•	•
2 1/2" SAE Stem							•	•	•	•	•	•	•	•	•		
2 1/2" Panel	•		•	•	•	•	•	•	•	•	•	•	•	•	•	•	•
4" Stem							•	•	•	•	•	•	•	•	•	•	•
4" Panel							•	•	•	•	•	•	•	•	•	•	•

2 1/2" Diameter Gauges

Stem Mount

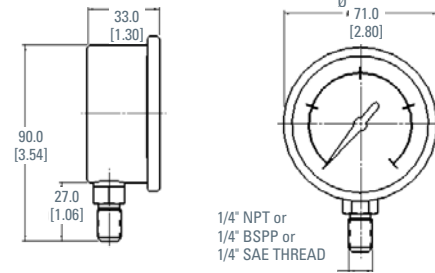

Front Flange Options

Part No.	Description	Dial Size
P562699	PGL-A-63-FF	2-1/2" (63mm)
P562671	PGL-A-100-FF	4" (100mm)

Panel Mount

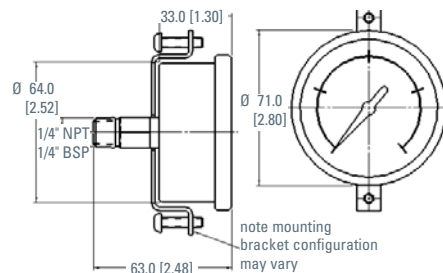

With Front Flange

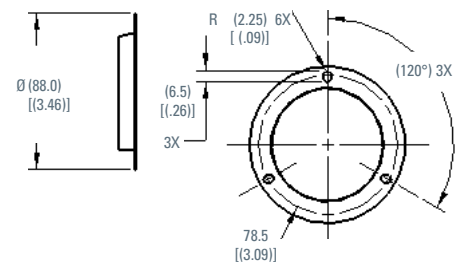

2 1/2" Stem Mount

Part No.	Description	Pressure Range (psi/bar)	Thread Type
P562718	PGL-A-63-N-B-30-CS	-30" Hg + 20/1	1/4" NPT
P562719	PGL-A-63-N-B-30-S	0 - 30/2	1/4" NPT
P562721	PGL-A-63-N-B-30-VS	0 - 30" Hg Vac	1/4" NPT
P562733	PGL-A-63-N-B-60-S	0 - 60/4	1/4" NPT
P562705	PGL-A-63-N-B-100-S	0 - 100/7	1/4" NPT
P562709	PGL-A-63-N-B-160-S	0 - 160/11	1/4" NPT
P562717	PGL-A-63-N-B-300-S	0 - 300/20	1/4" NPT
P562727	PGL-A-63-N-B-500-S	0 - 500/35	1/4" NPT
P562731	PGL-A-63-N-B-600-S	0 - 600/40	1/4" NPT
P562703	PGL-A-63-N-B-1000-S	0 - 1,000/70	1/4" NPT
P562707	PGL-A-63-N-B-1500-S	0 - 1,500/100	1/4" NPT
P562711	PGL-A-63-N-B-2000-S	0 - 2,000/125	1/4" NPT
P562713	PGL-A-63-N-B-3000-S	0 - 3,000/200	1/4" NPT
P562723	PGL-A-63-N-B-4000-S	0 - 4,000/275	1/4" NPT
P562725	PGL-A-63-N-B-5000/345-S	0 - 5,000/350	1/4" NPT
P562729	PGL-A-63-N-B-6000-S	0 - 6,000/400	1/4" NPT
P562701	PGL-A-63-N-B-10,000-S	0 - 10,000/700	1/4" NPT
P562696	PGL-A-63-B-B-1500-S	0 - 1,500/100	1/4" BSP
P562739	PGL-A-63-S-B-500-S	0 - 500/35	1/4" SAE
P562734	PGL-A-63-S-B-1000-S	0 - 1,000/70	1/4" SAE
P562735	PGL-A-63-S-B-1500-S	0 - 1,500/100	1/4" SAE
P562736	PGL-A-63-S-B-2000-S	0 - 2,000/125	1/4" SAE
P562737	PGL-A-63-S-B-3000-S	0 - 3,000/200	1/4" SAE
P562738	PGL-A-63-S-B-5000/345-S	0 - 5,000/350	1/4" SAE
P562740	PGL-A-63-S-B-6000-S	0 - 6,000/400	1/4" SAE

2 1/2" Panel Mount

Part No.	Description	Pressure Range (psi/bar)	Thread Type
P562720	PGL-A-63-N-B-30-VP	0 - 30" Hg Vac	1/4" NPT
P562732	PGL-A-63-N-B-60-P	0 - 60/4	1/4" NPT
P562704	PGL-A-63-N-B-100-P	0 - 100/7	1/4" NPT
P562708	PGL-A-63-N-B-160-P	0 - 160/11	1/4" NPT
P562716	PGL-A-63-N-B-300-P	0 - 300/20	1/4" NPT
P562726	PGL-A-63-N-B-500-P	0 - 500/35	1/4" NPT
P562730	PGL-A-63-N-B-600-P	0 - 600/40	1/4" NPT
P562702	PGL-A-63-N-B-1000-P	0 - 1,000/70	1/4" NPT
P562706	PGL-A-63-N-B-1500-P	0 - 1,500/100	1/4" NPT
P562710	PGL-A-63-N-B-2000-P	0 - 2,000/125	1/4" NPT
P562712	PGL-A-63-N-B-3000-P	0 - 3,000/200	1/4" NPT
P562722	PGL-A-63-N-B-4000-P	0 - 4,000/275	1/4" NPT
P562724	PGL-A-63-N-B-5000/345-P	0 - 5,000/350	1/4" NPT
P562728	PGL-A-63-N-B-6000-P	0 - 6,000/400	1/4" NPT
P562700	PGL-A-63-N-B-10,000-P	0 - 10,000/700	1/4" NPT
P562697	PGL-A-63-B-B-3000-P	0 - 3,000/200	1/4" BSP
P562698	PGL-A-63-B-B-4000-P	0 - 4,000/275	1/4" BSP



4" Diameter Gauges

Stem Mount

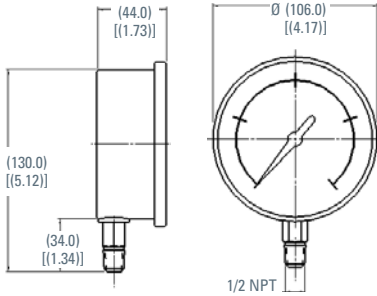

Panel Mount

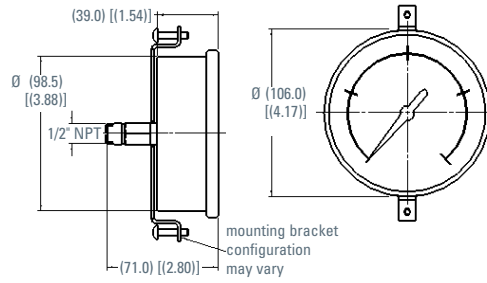

With Front Flange

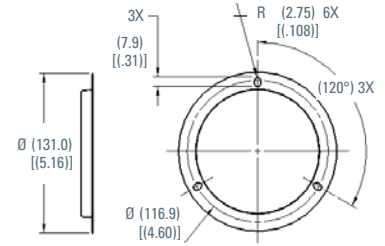

4" Stem Mount

Part No.	Description	Pressure Range (psi/bar)	Thread Type
P562683	PGL-A-100-N-B-300-S	0 - 300/20	1/2" NPT
P562688	PGL-A-100-N-B-600-S	0 - 600/40	1/2" NPT
P562675	PGL-A-100-N-B-1000-S	0 - 1,000/70	1/2" NPT
P562677	PGL-A-100-N-B-1500-S	0 - 1,500/100	1/2" NPT
P562679	PGL-A-100-N-B-2000-S	0 - 2,000/125	1/2" NPT
P562681	PGL-A-100-N-B-3000-S	0 - 3,000/200	1/2" NPT
P562685	PGL-A-100-N-B-5000	0 - 5,000/350	1/2" NPT
P562686	PGL-A-100-N-B-6000-S	0 - 6,000/400	1/2" NPT
P562673	PGL-A-100-N-B-10,000-S	0 - 10,000/700	1/2" NPT

4" Panel Mount

Part No.	Description	Pressure Range (psi/bar)	Thread Type
P562682	PGL-A-100-N-B-300-P	0 - 300/20	1/2" NPT
P562687	PGL-A-100-N-B-600-P	0 - 600/40	1/2" NPT
P562674	PGL-A-100-N-B-1000-P	0 - 1,000/70	1/2" NPT
P562676	PGL-A-100-N-B-1500-P	0 - 1,500/100	1/2" NPT
P562678	PGL-A-100-N-B-2000-P	0 - 2,000/125	1/2" NPT
P562680	PGL-A-100-N-B-3000-P	0 - 3,000/200	1/2" NPT
P562684	PGL-A-100-N-B-5000	0 - 5,000/350	1/2" NPT
P562672	PGL-A-100-N-B-10,000-P	0 - 10,000/700	1/2" NPT



Test Points

Specifications

- Working Pressure: 9000 psi / 630 bar
- Seals: Nitrile
- Caps: Plastic or metal
- Leak-free connection at full pressure



Features

Test points can be used as a connection into the hydraulic system on the suction side, pressure side or return. They allow connection for pressure transducers and provide ports for fluid sampling (so you can monitor cleanliness and keep your system operating optimally). If you have filters installed in hard-to-access locations, test points and hose assemblies can be used to plumb up a bulkhead to read pressure differentials.

Styles	Temperature Range
<ul style="list-style-type: none"> • Pressure 	<ul style="list-style-type: none"> • Metal cap: -22°F to 248°F / -30°C to 120°C
Applications	<ul style="list-style-type: none"> • Plastic cap: -22°F to 212°F / -30°C to 100°C
<ul style="list-style-type: none"> • Fluid or gas 	



TPM/TPP-1215 Assembly Views M12x1.5 Thread

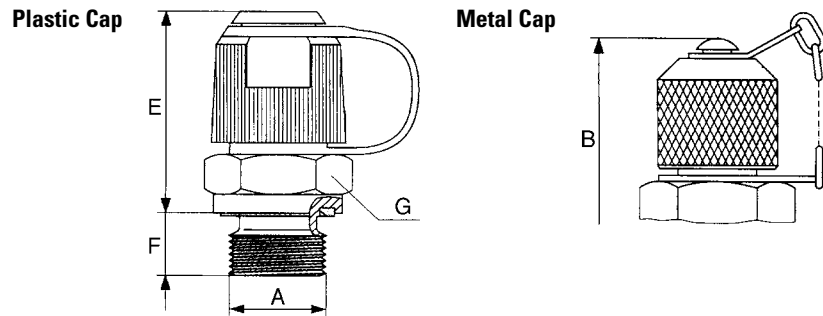

Test Point Choices

Part No.	Description	Working Pressure psi/bar	A Thread Type	E (in/mm)	F (in/mm)	G (in/mm)	Cap
P563192	TPM-1215-04G	9000/630	1/4" BSPP, Form G	1.30/33	.33/8.5	0.55/14	Metal
P563197	TPP-1215-02N	5800/400	1/8" NPTF	1.14/29	.47/12	0.55/14	Plastic
P563193	TPM-1215-04N	9000/630	1/4" NPTF	1.14/29	.59/15	0.55/14	Metal
P563199	TPP-1215-03S	9000/630	3/8"-24 UNF (#3 SAE)	1.42/36	.39/10	0.87/22	Plastic
P563206	TPP-1215-04S	9000/630	7/16"-20 UNF (#4 SAE)	1.26/32	.35/9	0.67/17	Plastic
P563207	TPP-1215-06S	9000/630	9/16"-18 UNF (#6 SAE)	1.22/31	.39/10	0.75/19	Plastic

TPM/TPP-1620 Assembly Views M16x2 Thread

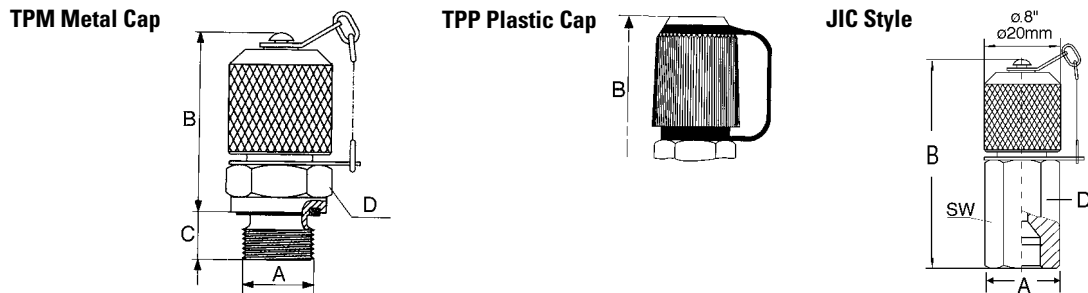

Test Point Choices

Part No.	Description	Working Pressure psi/bar	A Thread Type	B (in/mm)	C (in/mm)	D (mm)	Cap
P563210	TPM-1620-02B	5800/400	ISO 228-G 1/8" BSPP	1.5/38	0.31/8	17	Metal
P563215	TPM-1620-04B	9000/630	ISO 228-G 1/4" BSPP	1.42/36	0.39/10	19	Metal
P563987	TPM-1620-06B	9000/630	ISO 228-G 3/8" BSPP	1.42/36	0.39/10	22	Metal
P563219	TPM-1620-04J	8100/600	#4 37° JIC Female	2.17/55	—	17	Metal
P563231	TPM-1620-06J	4500/315	#6 37° JIC Female	2.26/57.5	—	19	Metal
P563212	TPM-1620-02N	5800/400	1/8" NPTF	1.3/33	0.51/13	17	Metal
P563220	TPM-1620-04N	9000/630	1/4" NPTF	1.3/33	0.65/16.5	17	Metal
P563224	TPM-1620-04S	9000/630	7/16"-20 UNF (#4 SAE)	1.46/37	0.35/9	17	Metal
P563232	TPM-1620-06S	9000/630	9/16"-18 UNF (#6 SAE)	1.42/36	0.39/10	19	Metal



Test Point Adapters



A variety of adapters to suit your application.

Hose Union Gauge

Part No.	Description	G Thread	psi/bar	L (in/mm)	SW (in/mm)
P563263	AHU-1215	M12 x 1.5	9000/630	1.14/29	.55/14
P563264	AHU-1620	M16 x 2	9000/630	1.65/42	.67/17

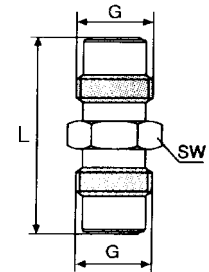

Direct Gauge Adapter

Part No.	Description	G Int. Thread	G1 Thread	psi/bar	L0 (in/mm)	SW (in/mm)
P563808	ADG-1215-04N	1/4" NPT	M12 x 1.5	9000/630	1.14/29	.55/14
P563809	ADG-1620-04N	1/4" NPT	M16 x 2	9000/630	.55/14	.75/19

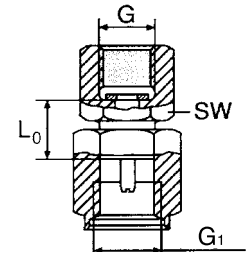

Series Converter

Part No.	Description	G1 Thread	G2 Thread	ØD (in/mm)	L (in/mm)	SW (in/mm)
P563265	ASC-1215	M16 x 2	M12 x 1.5	.67/17	1.30/33	.67/17
P563266	ASC-1620	M12 x 1.5	M16 x 2	.79/20	1.04/26.5	.67/17

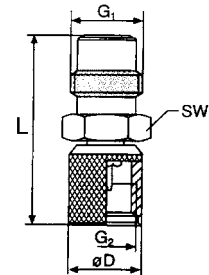

Bulkhead Gauge Adaptor

Part No.	Description	G1 Thread	G2 Thread	L (in/mm)	SW (in/mm)
P563800	ABH-1215-04N	1/4" NPT	1215M 12 x 1.5	1.52/39.5	.75/27
P563807	ASC-1620-04N	1/4" NPT	1620/M16 x 2	1.52/38.5	.75/19

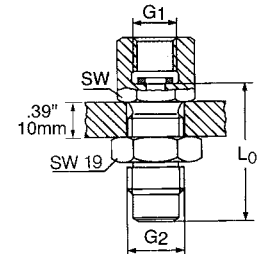

Pressure Gauge Connection

Part No.	Description	G Thread	G1 Thread	psi/bar	L (in/mm)	SW (in/mm)
P563262	AHG-1215-04N	1/4" NPT	M12 x 1.5	9000/630	.71/18	.74/19

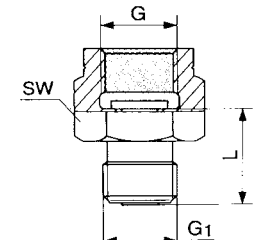

Test Point Hose Assemblies

Specifications

- Working Pressure to:
9000 psi / 630 bar
- Temperature Range:
-4°F to 212°F / -20°C to 100°C
- Length:
12" to 180" / 305mm to 4570mm



Features

Donaldson test point hoses are made of Polyamide 11 core with polyester braid reinforcement and Polyamide 11 cover. They are suitable for use with petroleum-based fluids. Hoses are standard straight on both ends and include plastic dust caps.

For hydraulic filters installed in hard-to-access locations, hose assemblies and test points can be used to plumb up a bulkhead to read pressure differentials.

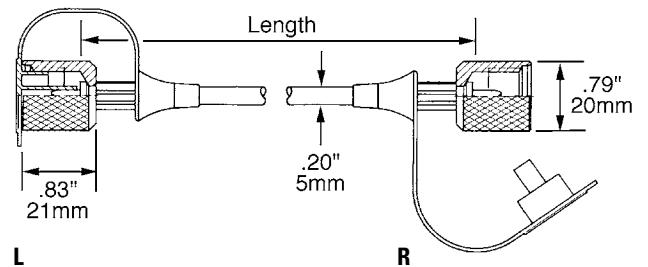
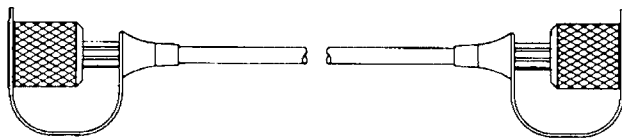

1215 Series M12x1.5 Thread

Part No.	Description	Length (in/mm)
P563240	H-1215-B-0101-012	12/305
P563243	H-1215-B-0101-024	24/610
P563244	H-1215-B-0101-036	36/915
P563245	H-1215-B-0101-048	48/1220
P563246	H-1215-B-0101-072	72/1830
P563247	H-1215-B-0101-096	96/2440
P563248	H-1215-B-0101-120	120/3050
P563249	H-1215-B-0101-180	80/4570

1620 Series M16x2 Thread

Part No.	Description	Length (in/mm)
P563250	H-1620-B-0101-012	12/305
P563251	H-1620-B-0101-018	18/460
P563252	H-1620-B-0101-024	24/610
P563254	H-1620-B-0101-036	36/915
P563255	H-1620-B-0101-048	48/1220
P563256	H-1620-B-0101-072	72/1830
P563257	H-1620-B-0101-096	96/2440
P563259	H-1620-B-0101-120	120/3050
P563260	H-1620-B-0101-144	144/3660
P563261	H-1620-B-0101-180	180/4570



In-Line Check Valves

Specifications

- Working Pressure to: 4350 psi / 300 bar
- Flow Range: 200 gpm 757 lpm



Features

Steel constructed check valves are compatible with all non-corrosive liquids. Valves contain no elastomeric seals. Restricted orifice (.062) option available on some models.

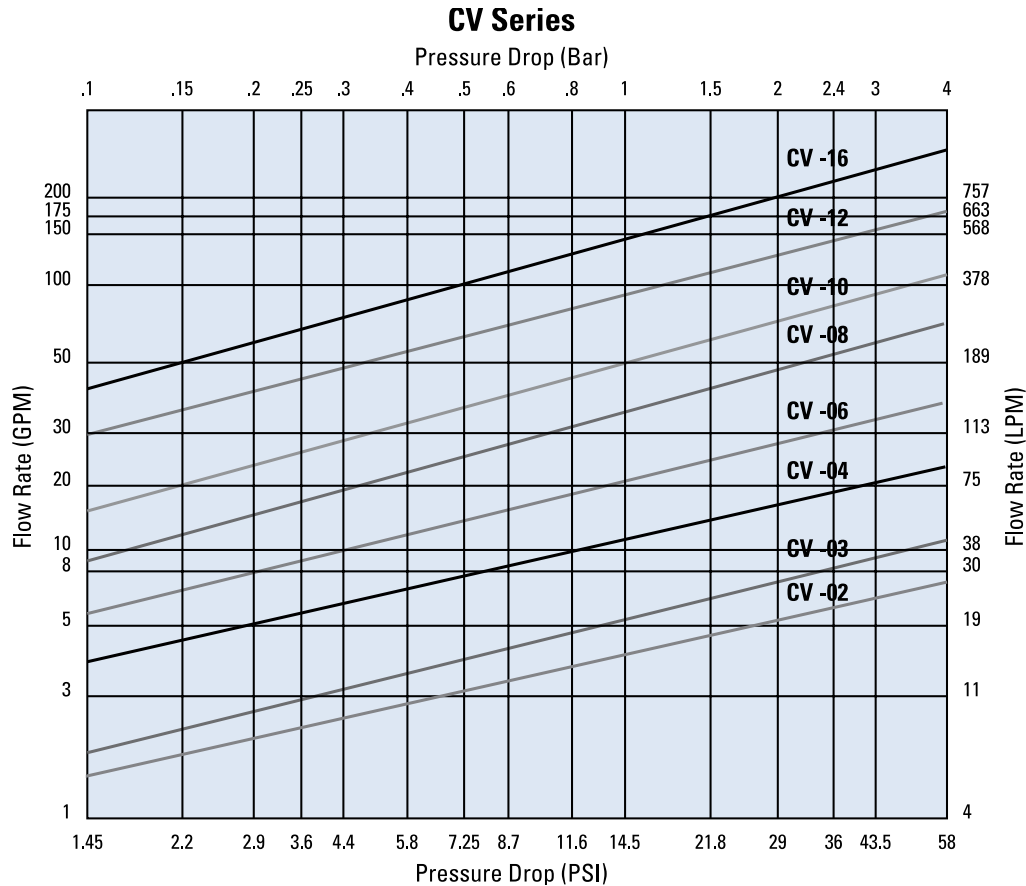

The above chart is based on Hydraulic Oil 100 SUS, S.G. = 0.86

Sizes	Opening Pressure (Cracking)
<ul style="list-style-type: none"> • ¼", 3/8", ½", ¾", 1", 1 ¼", 1 ½" and 2" NPT • #4, #6, #8, #12, #16, #20, #24 and #32 SAE 	<ul style="list-style-type: none"> • 5 psi / 0.34 bar or 65 psi / 4.5 bar



In-Line Check Valve Options

Part No.	Reference	Max Working Pressure (psi/bar)	Max. Rated Flow Flow (gpm/lpm)	Opening Pressure (psi/bar)	Port	A (in/mm)	B (in/mm)
P562297	CV-02P-5	4350/300	6/23	5/0.34	1/4" NPT	0.75/19	2.17/55
P562298	CV-02P-65	4350/300	6/23	65/4.5	1/4" NPT	0.75/19	2.17/55
P562299	CV-02S-5	4350/300	6/23	5/0.34	#4 SAE	0.75/19	2.17/55
P562301	CV-03P-5	4350/300	10/38	5/0.34	3/8" NPT	0.98/25	2.68/68
P562302	CV-03P-65	4350/300	10/38	65/4.5	3/8" NPT	0.98/25	2.68/68
P562303	CV-03S-5	4350/300	10/38	5/0.34	#6 SAE	0.75/19	2.29/58
P562305	CV-04P-5	4350/300	16/60	5/0.34	1/2" NPT	1.06/27	2.95/75
P562306	CV-04P-65	4350/300	16/60	65/4.5	1/2" NPT	1.06/27	2.95/75
P562307	CV-04S-5	4350/300	16/60	5/0.34	#8 SAE	0.98/25	2.72/69
P562308	CV-04S-65	4350/300	16/60	65/4.5	#8 SAE	0.98/25	2.72/69
P562309	CV-06P-5	4350/300	25/94	5/0.34	3/4" NPT	1.38/35	3.48/88
P562311	CV-06P-65	4350/300	25/94	65/4.5	3/4" NPT	1.38/35	3.48/88
P562312	CV-06S-5	4350/300	25/94	5/0.34	#12 SAE	1.38/35	3.48/88
P562313	CV-06S-65	4350/300	25/94	65/4.5	#12 SAE	1.38/35	3.48/88
P562314	CV-08P-5	4350/300	45/169	5/0.34	1" NPT	1.61/41	4.33/110
P562316	CV-08P-65	4350/300	45/169	65/4.5	1" NPT	1.61/41	4.33/110
P562317	CV-08S-5	4350/300	45/169	5/0.34	#16 SAE	1.61/41	4.33/110
P563307	CV-08S-65	4350/300	45/169	65/4.5	#16 SAE	1.61/41	4.33/110
P562319	CV-10P-5	4350/300	95/357	5/0.34	1-1/4" NPT	2.16/55	4.72/120
P562320	CV-10P-65	4350/300	95/357	65/4.5	1-1/4" NPT	2.16/55	4.72/120
P562321	CV-10S-5	4350/300	95/357	5/0.34	#20 SAE	2.16/55	4.72/120
P562322	CV-10S-65	4350/300	95/357	65/4.5	#20 SAE	2.16/55	4.72/120
P562323	CV-12P-5	4350/300	130/489	5/0.34	1-1/2" NPT	2.56/65	5.43/138
P562324	CV-12P-65	4350/300	130/489	65/4.5	1-1/2" NPT	2.56/65	5.43/138
P562325	CV-12S-5	4350/300	130/489	5/0.34	#24 SAE	2.56/65	5.43/138
P562326	CV-12S-65	4350/300	130/489	65/4.5	#24 SAE	2.56/65	5.43/138
P562327	CV-16P-5	2900/200	200/752	5/0.34	2" NPT	2.56/65	5.43/138
P562328	CV-16P-65	2900/200	200/752	65/4.5	2" NPT	2.56/65	5.43/138

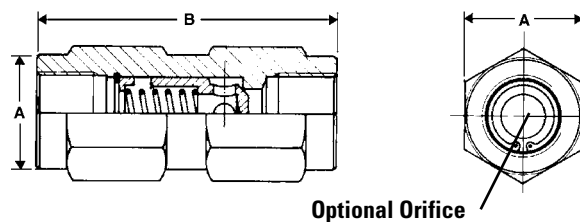



Ball Valves - Low Pressure

Specifications

- Hot pressed brass body and ball OT 58
- Materials (ball and body): BV Series chromium plated
- Steel handle
- Teflon® seals (ball and stem)

Teflon® is a registered trademark of E. I. DuPont de Nemours and Company.

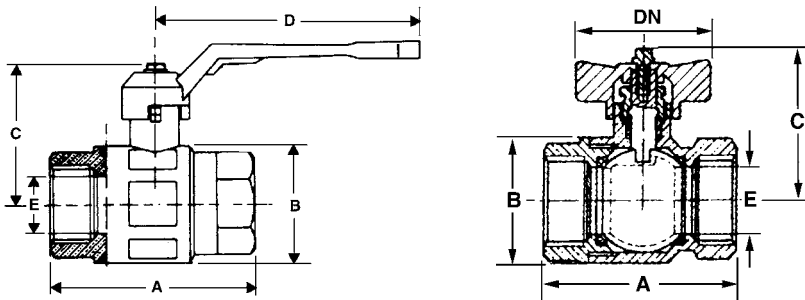

Features

Low pressure ball valves are rated for water, oil or gas (WOG) applications. Two-way/two-position, quarter turn operation. Full-ported sizes from 1/4" to 2" NPT. T-handle available on some models. Suitable for temperatures from -22°F to 350°F (-30°C to 162°C).

Ball Valve Options

Part No.	Description	Max. Working Pressure (psi/bar)	Port Thread	Dimensions (in/mm)				
				A	B	C	D	E
P562331	BV-04-N	710/49	1/4" NPT	1.89/48	0.98/25	1.69/43	3.15/80	0.40/10
P562333	BV-06-N	710/49	3/8" NPT	1.89/48	0.98/25	1.69/43	3.15/80	0.40/10
P562336	BV-08-N	710/49	1/2" NPT	2.00/51	1.22/31	1.77/45	3.15/80	0.60/15
P563311	BV-12-N	570/39	3/4" NPT	2.24/57	1.46/37	2.36/60	4.44/113	0.80/20
P562338	BV-16-N	570/39	1" NPT	2.75/70	1.81/46	2.48/63	4.44/113	1.00/25
P562339	BV-20-N	430/30	1-1/4" NPT	3.15/80	2.24/57	3.11/79	5.43/138	1.25/32
P562341	BV-24-N	430/30	1-1/2" NPT	3.66/93	2.75/70	3.27/83	5.43/138	1.57/40
P562343	BV-32-N	360/25	2" NPT	4.41/112	3.31/84	3.94/100	6.22/158	1.97/50
P562345	BV-40-N	260/18	2-1/2" NPT	5.31/135	3.82/97	3.98/101	7.75/197	2.12/54
P562346	BV-48-N	230/16	3" NPT	6.25/159	4.80/122	5.08/129	9.84/250	2.56/65



Split Flanges

Specifications

- Code 61 and Code 62
- Nitrile O-Ring

Each kit includes:

- 2 split flange halves
- 4 hex head mounting bolts and lock washers
- 1 Nitrile O-Ring

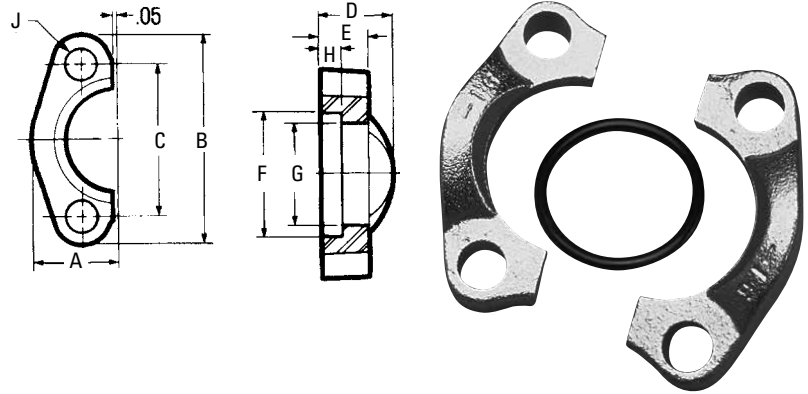

Code 61

Part No.	Reference	Flange Size	Dimensions (in/mm)									Mounting Hardware		Max. Working Pressure
			A	B	C	D	E	F	G	H	J (Dia.)	O-Ring	Hex Head Cap Screw	
P563042	L-12SF-3	0.75	0.98	2.56	1.875	0.88	0.56	1.531	1.265	0.245	0.406	-214	3/8"-16x11/4	5000
		19	25	65	48	22	14	39	32	6	10			34500kPa
P563044	L-16SF-3	1.00	1.11	2.75	2.062	0.94	0.62	1.781	1.515	0.295	0.406	-219	3/8"-16x11/4	5000
		25	28	70	52	24	16	45	38	7	10			34500kPa
P563047	L-20SF-3	1.25	1.39	3.12	2.312	0.88	0.56	2.031	1.720	0.295	0.469	-222	7/16"-14x11/2	4000 psi
		32	35	79	59	22	14	52	44	7	12			27580 kPa
P563050	L-24SF-3	1.50	1.58	3.69	2.750	1.00	0.62	2.406	2.000	0.295	0.531	-225	1/2"-13x11/2	3000 psi
		38	40	94	70	25	16	61	51	8	13			20685 kPa
P563053	L-32SF-3	2.00	1.86	4.00	3.062	1.03	0.62	2.844	2.470	0.355	0.531	-228	1/2"-13x11/2	3000 psi
		51	47	102	78	26	16	72	63	9	13			20685 kPa
P563056	L-40SF-3	2.50	2.09	4.50	3.500	1.50	0.75	3.344	2.950	0.355	0.531	-232	1/2"-13x13/4	2500 psi
		64	53	114	89	38	19	85	75	9	13			17240 kPa

Code 62 Mounting Hardware

Part No.	Reference	Flange Size	Dimensions (in/mm)									Mounting Hardware		Max. Working Pressure
			A	B	C	D	E	F	G	H	J (Dia.)	O-Ring	Hex Head Cap Screw	
P563046	L-16SFX-6	1.00	1.33	3.19	2.250	1.31	0.94	1.906	1.530	0.355	0.469	-219	7/16"-14x13/4	6000 psi
		25	34	81	57	33	24	48	39	9	12			41370kPa
P563049	L-20SFX-6	1.25	1.48	3.75	2.625	1.50	1.06	2.156	1.750	0.385	0.531	-222	1/2"-13x13/4	6000 psi
		32	38	95	67	38	27	55	44	10	13			41370kPa
P563051	L-24SFX-6	1.50	1.83	4.44	3.125	1.69	1.19	2.531	2.030	0.475	0.656	-225	5/8"-11x21/4	6000 psi
		38	46	113	79	43	30	64	52	12	17			41370kPa
P563054	L-32SFX-6	2.00	2.20	5.25	3.812	2.06	1.44	3.156	2.660	0.475	0.781	-228	3/4"-10x23/4	6000 psi
		51	56	133	97	52	37	80	68	12	20			41370kPa

Blanking Flanges

Specifications

- Code 61 and 62
- O-Ring

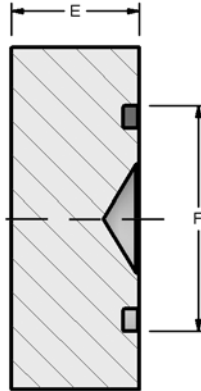
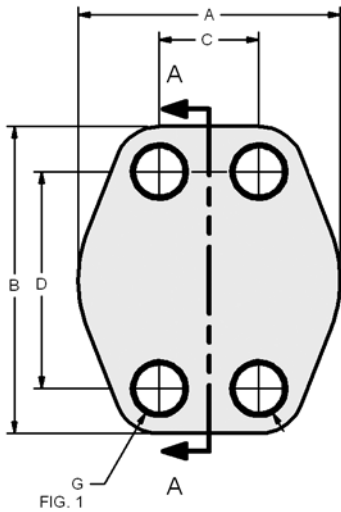
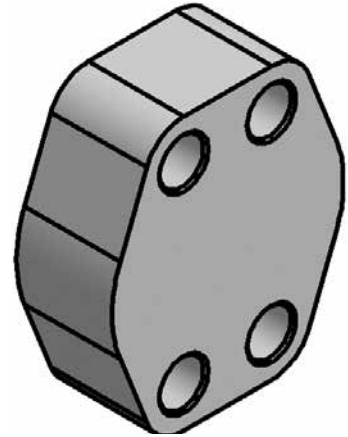

Blanking Flanges, Code 61

Part No.	Reference	Pad Size	Dimensions (in/mm)							Mounting Hardware	
			A	B	C	D	E	F	G	O-Ring	SHCS
P563061	LIB-16-16-30	1"/25mm	2.313/59	2.750/70	1.031/26	2.063/52	0.88/22	1.560/40	0.406/10	-219	3/8"-16x1.75
P563063	LIB-20-20-30	1-1/4"/32mm	2.875/73	3.125/79	1.188/30	2.313/59	0.94/24	1.750/44	0.469/12	-222	7/16"-14x1.75
P563065	LIB-24-24-30	1-1/2"/38mm	3.250/83	3.688/94	1.406/36	2.750/70	1.19/30	2.115/54	0.531/13	-225	1/2"-13x2.25
P563067	LIB-32-32-30	2"/51mm	3.813/97	4.000/102	1.688/43	3.063/78	1.44/37	2.490/63	0.531/13	-228	1/2"-13x2.50

Blanking Flanges, Code 62

Part No.	Reference	Pad Size	Dimensions (in/mm)							Mounting Hardware	
			A	B	C	D	E	F	G	O-Ring	SHCS
P563064	LIB-20-20-60	1-1/4"/32mm	3.060/78	3.750/95	1.250/32	2.625/67	1.43/36	1.750/44	0.531/13	-222	1/2"-13x2.50

4-Bolt NPTF Threaded Flange

Specifications

- Code 61 and 62
- NPT Thread
- Nitrile O-Ring
- Mounting hardware and O-Ring included on O-Ring models
- Maximum temperature with O-Ring 250°F / 121°C

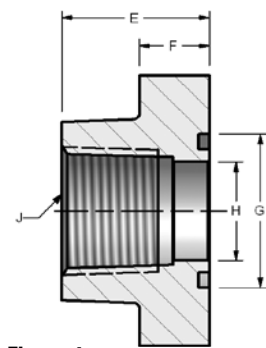
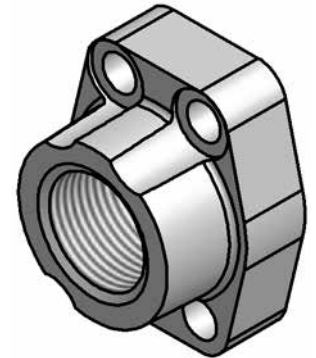
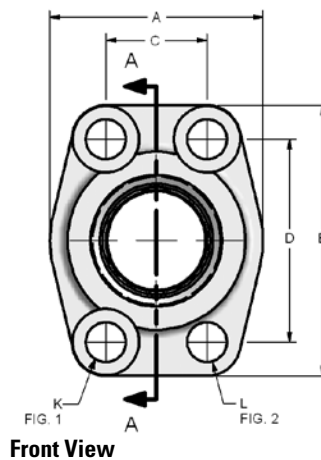

Figure 1



Front View

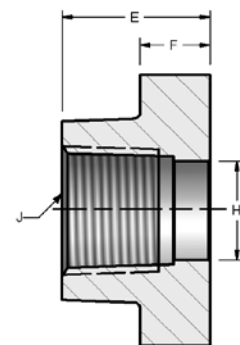

Figure 2

Code 61 NPTF Thread, O-Ring (Figure 1)

Part No.	Description	Port Size	Pad Size	Dimensions (in/mm)								J NPTF	K (dia.) Drill	Mounting Hardware	
				A	B	C	D	E	F	G	H			O-Ring	SHCS
P563088	LI-12-12P-30	0.75	0.75	1.97	2.56	0.875	1.875	1.42	0.71	1.250	0.752	3/4"-14	0.406	-214	3/8"-16 x 1.25
		19	19	50	65	22	48	36	18	32	19		10		
P563093	LI-16-16P-30	1.00	1.00	2.17	2.75	1.031	2.062	1.50	0.71	1.560	1.002	1"-11.5	0.406	-219	3/8"-16 x 1.50
		25	25	55	70	26	52	38	18	40	25		10		
P563100	LI-20-20P-30	1.25	1.25	2.68	3.12	1.188	2.312	1.61	0.83	1.750	1.252	1-1/4"-11.5	0.469	-222	7/16"-14 x 1.50
		32	32	68	79	30	59	41	21	44	32		12		
P563107	LI-24-24P-30	1.50	1.50	3.07	3.66	1.406	2.750	1.77	0.98	2.115	1.502	1-1/2"-11.5	0.531	-225	1/2"-13 x 1.75
		38	38	78	93	36	70	45	25	54	38		13		
P563113	LI-32-32P-30	2.00	2.00	3.54	4.00	1.688	3.062	1.77	0.98	2.490	2.002	2"-11.5	0.531	-228	1/2"-13 x 1.75
		51	51	90	102	43	78	45	25	63	51		13		
P563117	LI-40-40P-30	2.50	2.50	4.09	4.49	2.000	3.500	1.97	0.98	2.995	2.502	2-1/2"-8	0.531	-232	1/2"-13 x 2.25
		64	64	104	114	51	89	50	25	76	64		13		
P563118	LI-48-48P-30	3.00	3.00	4.88	5.28	2.438	4.188	1.97	1.06	3.615	3.002	3"-8	0.656	-237	5/8"-11 x 2.50
		76	76	124	134	62	106	50	27	92	76		17		

4-Bolt NPTF Threaded Flange

Code 61 NPTF Thread, Flat Face (Figure 2)

Part No.	Description	Port Size	Pad Size	Dimensions (in/mm)									L Tap	
				A	B	C	D	E	F	G	H	J NPTF	UNC-2B	
P563163	LIC-16-16P-30	1.00	1.00	2.17	2.75	1.031	2.062	1.50	0.71	1.560	1.002	1"-11.5	3/8"-16	
		25	25	55	70	26	52	38	18	40	25			
P563166	LIC-20-20P-30	1.25	1.25	2.68	3.12	1.188	2.312	1.61	0.83	1.750	1.252	1-1/4"-11.5	7/16"-14	
		32	32	68	79	30	59	41	21	44	32			
P563171	LIC-32-32P-30	2.00	2.00	3.54	4.00	1.688	3.062	1.77	0.98	2.490	2.002	2"-11.5	1/2"-13	
		51	51	90	102	43	78	45	25	63	51			

Code 62 NPTF Thread, O-Ring (Figure 1)

Part No.	Description	Port Size	Pad Size	Dimensions (in/mm)									K (dia.)	Mounting Hardware	
				A	B	C	D	E	F	G	H	J NPTF	Drill	O-Ring	SHCS
P563094	LI-16-16P-60	1.00	1.00	2.56	3.19	1.093	2.250	1.65	0.98	1.560	1.002	1-11.5	0.492	-219	7/16"-14 x 1.50
		25	25	65	81	28	57	42	25	40	25		12		
P563101	LI-20-20P-60	1.25	1.25	3.07	3.75	1.250	2.625	1.77	1.06	1.750	1.252	1-1/4-11.5	0.531	-222	1/2"-13 x 1.50
		32	32	78	95	32	67	45	27	44	32		13		
P563108	LI-24-24P-60	1.50	1.50	3.70	4.41	1.437	3.125	1.97	1.18	2.115	1.502	1-1/2-11.5	0.656	-225	5/8"-11 x 1.75
		38	38	94	112	36	79	50	30	54	38		17		



4-Bolt SAE Threaded Flange

Specifications

- Code 61 and 62
- SAE Straight Thread
- Nitrile O-Ring
- Mounting hardware and O-Ring included on O-Ring models
- Maximum temperature with O-Ring 250°F / 121°C

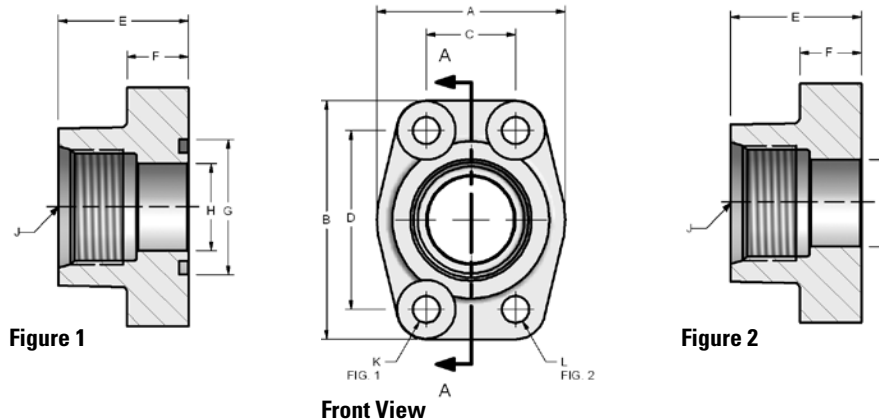
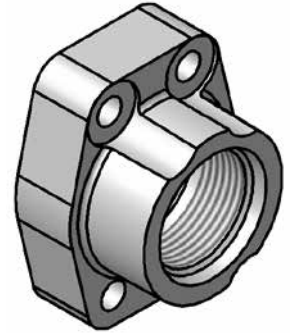

Code 61 Straight Thread, O-Ring (Figure 1)

Part No.	Reference	Port Size	Pad Size	Dimensions (in/mm)								J UN/UNF-2B	K (Dia.) Drill	Mounting Hardware	
				A	B	C	D	E	F	G	H			O-Ring	SHCS
P563090	LI-12-12S-30	0.75/19	0.75/19	1.97/50	2.56/65	0.875/22	1.875/48	1.42/36	0.71/18	1.250/32	0.752/19	1 1/16"-12	0.406/10	-214	3/8"-16 x 1.25
P563095	LI-16-16S-30	1.00/25	1.0/25	2.17/55	2.75/70	1.031/26	2.062/52	1.50/38	0.71/18	1.560/40	1.002/25	1 5/16"-12	0.406/10	-219	3/8"-16 x 1.50
P563102	LI-20-20S-30	1.25/32	1.25/32	2.68/68	3.12/79	1.188/30	2.312/59	1.61/41	0.83/21	1.750/44	1.252/32	1 5/8"-12	0.469/12	-222	7/16"-14 x 1.50
P563109	LI-24-24S-30	1.50/38	1.50/38	3.07/78	3.66/93	1.406/36	2.750/70	1.77/45	0.98/25	2.115/54	1.502/38	1 7/8"-12	0.531/13	-225	1/2"-13 x 1.75
P563115	LI-32-32S-30	2.00/51	2.00/51	3.54/90	4.00/102	1.688/43	3.062/78	1.77/45	0.98/25	2.490/63	2.002/51	2 1/2"-12	0.531/13	-228	1/2"-13 x 1.75

Code 61 Straight Thread, Flat Face (Figure 2)

Part No.	Reference	Port Size	Pad Size	Dimensions (in/mm)								J UN/UNF-2B	L Tap UNC-2B
				A	B	C	D	E	F	G	H		
P563162	LIC-12-12S-30	0.75/19	0.75/19	1.97/50	2.56/65	0.875/22	1.875/48	1.42/36	0.71/18	1.250/32	0.752/19	1 1/16"-12	3/8"-16
P563165	LIC-16-16S-30	1.00/25	1.00/25	2.17/55	2.75/70	1.031/26	2.062/52	1.50/38	0.71/18	1.560/40	1.002/25	1 5/16"-12	3/8"-16
P563168	LIC-20-20S-30	1.25/32	1.25/32	2.68/68	3.12/79	1.188/30	2.312/59	1.61/41	0.83/21	1.750/44	1.252/32	1 5/8"-12	7/16"-14

Code 62 Straight Thread, O-Ring (Figure 1)

Part No.	Reference	Port Size	Pad Size	Dimensions (in/mm)								J UN/UNF-2B	K (Dia.) Drill	Mounting Hardware	
				A	B	C	D	E	F	G	H			O-Ring	SHCS
P563096	LI-16-16S-60	1.00/25	1.00/25	2.56/65	3.19/81	1.093/28	2.250/57	1.65/42	0.98/25	1.560/40	1.002/25	1 5/16-12	0.492/12	-219	7/16"-14 x 1.50
P563103	LI-20-20S-60	1.25/32	1.25/32	3.07/78	3.75/95	1.250/32	2.625/67	1.77/45	1.06/27	1.750/44	1.252/32	1 5/8"-12	0.531/13	-222	1/2"-13 x 1.75
P563110	LI-24-24S-60	1.50/38	1.50/38	3.70/94	4.41/112	1.437/36	3.125/79	1.97/50	1.18/30	2.115/54	1.502/38	1 7/8"-12	0.656/17	-225	5/8"-11 x 2.25



Flat Socket Weld Flange

Specifications

- Code 61 and 62

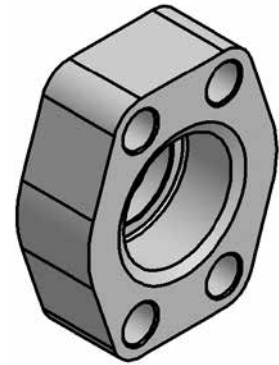
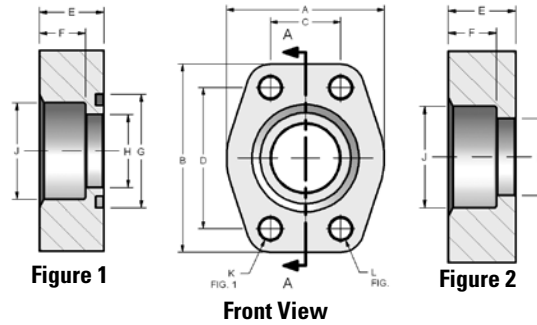

Code 61, O-Ring (Figure 1)

Part No.	Desc.	Pipe Size	Pad Size	Dimensions (in/mm)										Mounting Hardware	
				A	B	C	D	E	F	G	H	J	K	O-Ring	SHCS
P563119	LI-08-08W-30	0.50/13	0.50/13	1.813/46	2.125/54	0.688/17	1.500/38	0.75/19	0.560/14	1.000/25	0.502/13	0.855/22	0.344/9	-210	5/16"-18x1.5
P563120	LI-12-12W-30	0.75/19	0.75/19	2.063/52	2.563/65	0.875/22	1.875/48	0.75/19	0.560/14	1.250/32	0.752/19	1.062/27	0.406/10	-214	3/8"-16x1.5
P563121	LI-16-16W-30	1.00/25	1.00/25	2.313/59	2.750/70	1.031/26	2.063/52	0.88/22	0.630/16	1.560/40	1.002/25	1.328/34	0.406/10	-219	3/8"-16x1.75
P563122	LI-20-20W-30	1.25/32	1.25/32	2.875/73	3.125/79	1.188/30	2.313/59	0.94/24	0.690/18	1.750/44	1.252/32	1.672/42	0.469/12	-222	7/16"-14x1.75
P563123	LI-24-24W-30	1.50/38	1.50/38	3.250/83	3.688/94	1.406/36	2.750/70	1.19/30	0.750/19	2.115/54	1.502/38	1.922/49	0.531/13	-225	1/2"-13x2.25
P563124	LI-32-32W-30	2.00/51	2.00/51	3.813/97	4.000/102	1.688/43	3.063/78	1.38/35	0.875/22	2.495/63	2.002/51	2.406/61	0.531/13	-228	1/2"-13x2.5
P563127	LI-48-48W-30	3.00/76	3.00/76	5.156/131	5.313/135	2.438/62	4.188/106	2.12/54	1.250/32	3.615/92	3.002/76	3.547/90	0.656/17	-237	5/8"-11x3.5

Code 61, Flat Face (Figure 2)

Part No.	Desc.	Pipe Size	Pad Size	Dimensions (in/mm)										L
				A	B	C	D	E	F	G	H	J	UNC-2B	
P563177	LIC-16-16W-30	1.00/25	1.00/25	2.313/59	2.750/70	1.031/26	2.063/52	0.88/22	0.630/16	1.560/40	1.002/25	1.328/34	3/8"-16	
P563178	LIC-20-20W-30	1.25/32	1.25/32	2.875/73	3.125/79	1.188/30	2.313/59	0.94/24	0.690/18	1.750/44	1.252/32	1.672/42	7/16"-14	
P563179	LIC-24-24W-30	1.50/38	1.50/38	3.250/83	3.688/94	1.406/36	2.750/70	1.19/30	0.750/19	2.115/54	1.502/38	1.922/49	1/2"-13	
P563180	LIC-32-32W-30	2.00/51	2.00/51	3.813/97	4.000/102	1.688/43	3.063/78	1.38/35	0.875/22	2.490/63	2.002/51	2.406/61	1/2"-13	
P563181	LIC-40-40W-30	2.50/64	2.50/64	4.281/109	4.500/114	2.000/51	3.500/89	1.75/44	1.000/25	2.995/76	2.502/64	2.906/74	1/2"-13	

Reservoir Accessories

- Suction strainers protect pumps from damage
- Diffusers for effectively reducing aeration, foaming, turbulence and noise caused by return lines
- Sight and level gauges available, including standard length, screw-in styles in plastic and steel for use in a variety of applications
- Plugs, caps and vents for small power units and gearboxes
- Filler breathers and caps in chrome, zinc epoxy-coated weatherproof finishes and corrosion-resistance technopolymer – lockable, dipsticks and side-mount versions available



T.R.A.P.™ THERMALLY REACTIVE
ADVANCED PROTECTION

T.R.A.P.™ Breather Technology (Thermally Reactive Advanced Protection)

T.R.A.P. breathers provide fast-acting protection against airborne moisture and particulate contamination. It stops solid particulate down to 3 µm at 97% efficiency as well as prevents moisture from entering the reservoir. Water-holding capacity is regenerated with every oil return phase for long service life. Its self-regenerating capability enables extended life.



Suction Strainers

Specifications

- Flow Range: 0-300 gpm / 0-1,140 lpm
- Outlet Port Size: 3/8" NPT to 4" NPT
- Stainless Steel Mesh
- Steel or nylon fittings
- Operating temperatures:
Steel fitting to 250°F / 121°C
Nylon fitting to 210°F / 100°C
- Relief valve available



Features

Donaldson suction strainers are zinc-plated, with stainless steel mesh screens and rugged steel core centers epoxy bonded to heavy gauge connector and end caps. Suction strainers filter petroleum-based hydraulic fluids, phosphate esters, water glycols, lubricating oils, coolants, and fuels in fluid reservoirs, sumps and similar applications. They are cleanable and reusable. Clean by swishing in non-caustic solvent, then blow dry from inner diameter to outer diameter with compressed air.

SEC (Steel Fitting) 200-300

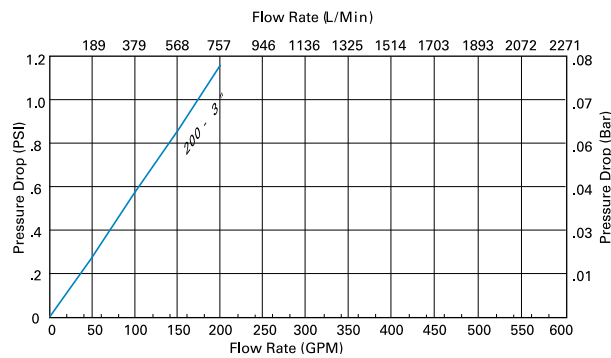

PEC (Nylon Fitting) 3-100

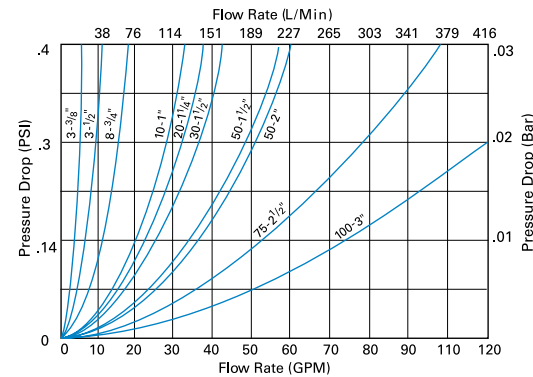

SEH/SEC (Steel Fitting) 3-100

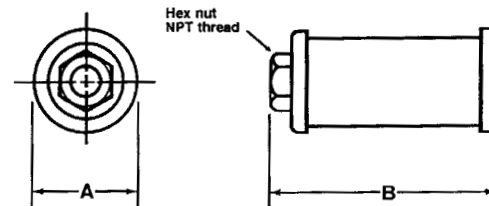
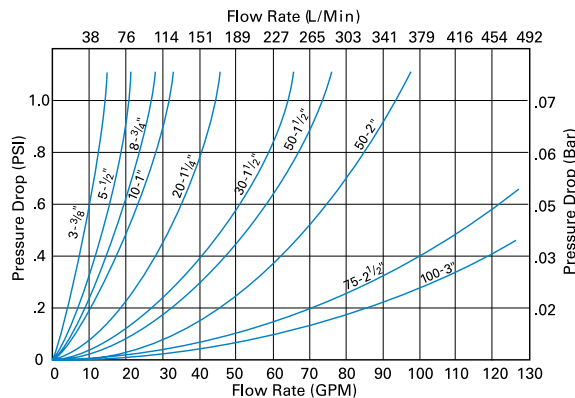

Note:
PEC and SEH model strainers have hex nut style outlet fittings. SEC model strainers have pipe coupling style (round) outlet fittings. All styles have NPT threads inside. Mount a minimum of 4" from the reservoir bottom.



Suction Strainer Choices

	Part No.	Description	Relief Valve Setting	Outlet Pipe Size	Wire Mesh Size	Dim. A (in/mm)	Dim. B (in/mm)	Screen Area (in ² /cm ²)	Max. Flow (gpm/lpm)
NYLON FITTING	P562235	PEC-3-3/8-100	n/a	3/8" NPT	100	1.9/48	2.7/69	20/129	3/11
	P562240	PEC-5-1/2-100	n/a	1/2" NPT	100	1.9/48	4.3/109	25/161	5/19
	P562245	PEC-8-3/4-100	n/a	3/4" NPT	100	2.7/69	4.3/109	40/258	8/30
	P562246	PEC-8-3/4-100-RV3	3 psid / 0.2 bar	3/4" NPT	100	2.7/69	4.3/109	40/258	8/30
	P562244	PEC-8-1-100	n/a	1" NPT	100	2.7/69	4.3/109	40/258	8/30
	P562226	PEC-10-1-100	n/a	1" NPT	100	2.7/69	5.6/142	70/452	10/38
	P562227	PEC-10-1-100-RV3	3 psid / 0.2 bar	1" NPT	100	2.7/69	5.6/142	70/452	10/38
	P562228	PEC-20-1.1/4-100	n/a	1-1/4" NPT	100	3.4/86	5.6/142	128/826	20/75
	P562229	PEC-20-1.1/4-100-RV3	3 psid / 0.2 bar	1-1/4" NPT	100	3.4/86	5.6/142	128/826	20/75
	P562231	PEC-20-1.1/4-200	n/a	1-1/4" NPT	200	3.4/86	5.6/142	128/826	20/75
	P562232	PEC-30-1.1/2-100	n/a	1-1/2" NPT	100	3.4/86	5.6/142	128/826	30/113
	P562233	PEC-30-1.1/2-100-RV3	3 psid / 0.2 bar	1-1/2" NPT	100	3.4/86	5.6/142	128/826	30/113
	P562236	PEC-50-1.1/2-100	n/a	1-1/2" NPT	100	4/102	8/203	200/1290	50/188
	P562237	PEC-50-1.1/2-100-RV3	3 psid / 0.2 bar	1-1/2" NPT	100	4/102	8/203	200/1290	50/188
	P562238	PEC-50-2-100	n/a	2" NPT	100	4/102	10.4/264	200/1290	50/188
	P562239	PEC-50-2-100-RV3	3 psid / 0.2 bar	2" NPT	100	4/102	10.4/264	200/1290	50/188
	P562242	PEC-75-2.1/2-100	n/a	2-1/2" NPT	100	5.2/132	8.5/216	316/2039	75/282
	P562243	PEC-75-2.1/2-100-RV3	3 psid / 0.2 bar	2-1/2" NPT	100	5.2/132	8.5/216	316/2039	75/282
P562223	PEC-100-3-100	n/a	3" NPT	100	5.2/132	11.5/292	379/2445	100/376	
P562224	PEC-100-3-100-RV3	3 psid / 0.2 bar	3" NPT	100	5.2/132	11.5/292	379/2445	100/376	
P562225	PEC-100-3-100-SST	n/a	3" NPT	100	5.2/132	11.5/292	379/2445	100/376	
STEEL FITTING	P562221	SEH-3-3/8-100	n/a	3/8" NPT	100	1.9/48	2.5/64	34/219	3/11
	P169012	SEH-5-1/2-100	n/a	1/2" NPT	100	2.63/67	3.1/79	62/400	5/19
	P563305	SEH-5-1/2-100-RV3	3 psid / 0.2 bar	1/2" NPT	100	2.7/69	3.1/79	62/400	5/19
	P169013	SEH-8-3/4-100	n/a	3/4" NPT	100	2.63/67	3.55/90	68/439	8/30
	P173910	SEH-8-3/4-100-RV3	3 psid / 0.2 bar	3/4" NPT	100	2.63/67	3.55/90	68/439	8/30
	P169014	SEH-10-1-100	n/a	1" NPT	100	2.63/67	5.35/136	110/710	10/38
	P173911	SEH-10-1-100-RV3	3 psid / 0.2 bar	1" NPT	100	2.63/67	5.35/136	110/710	10/38
	P169015	SEH-20-1.1/4-100	n/a	1-1/4" NPT	100	3.38/86	6.85/174	162/1045	20/75
	P173912	SEH-20-1.1/4-100-RV3	3 psid / 0.2 bar	1-1/4" NPT	100	3.38/86	6.85/174	162/1045	20/75
	P169016	SEH-30-1.1/2-100	n/a	1-1/2" NPT	100	3.38/86	8.01/203	225/1452	30/113
	P173913	SEH-30-1.1/2-100-RV3	3 psid/0.2 bar	1-1/2" NPT	100	3.38/86	8.01/203	225/1452	30/113
	P169017	SEH-50-1.1/2-100	n/a	1-1/2" NPT	100	3.94/100	9.8/249	340/2194	50/188
	P173914	SEH-50-1.1/2-100-RV3	3 psid / 0.2 bar	1-1/2" NPT	100	3.94/100	9.8/249	340/2194	50/188
	P562222	SEH-50-1.1/2-60	n/a	1-1/2" NPT	60	3.94/100	9.8/249	340/2194	50/188
	P169018	SEH-50-2-100	n/a	2" NPT	100	3.94/100	9.8/249	340/2194	50/188
	P173915	SEH-50-2-100-RV3	3 psid / 0.2 bar	2" NPT	100	3.94/100	9.8/249	340/2194	50/188
	P169019	SEC-75-2.1/2-100	n/a	2-1/2" NPT	100	5.12/130	10.1/257	400/2581	75/282
	P173916	SEC-75-2.1/2-100-RV3	3 psid / 0.2 bar	2-1/2" NPT	100	5.12/130	10.1/257	400/2581	75/282
	P169020	SEC-100-3-100	n/a	3" NPT	100	5.12/130	11.78/299	500/3226	100/376
	P173917	SEC-100-3-100-RV3	3 psid / 0.2 bar	3" NPT	100	5.12/130	11.78/299	500/3226	100/376
	P562211	SEC-100-3-60	n/a	3" NPT	60	5.12/130	11.78/299	500/3226	100/376
	P562212	SEC-100-3-60-RV3	3 psid / 0.2 bar	3" NPT	60	5.12/130	11.78/299	500/3226	100/376
	P562213	SEC-200-3-100	n/a	3" NPT	100	8.1/206	11.3/287	965/6226	200/752
	P562214	SEC-300-4-100	n/a	4" NPT	100	8.1/206	15/381	1370/8839	300/1128
	P171861	FIOA 20	n/a	G3/8"	90 micron	2.05/52	3.03/77	29/184	2.7/10
	P171869	FIOA 50	n/a	G3/4"	90 micron	2.95/75	3.74/95	54/348	6.6/25
	P171877	FIOA 90	n/a	G1"	90 micron	2.95/75	5.55/141	86/554	12.0/45
	P171885	FIOA 130	n/a	G1 1/4"	90 micron	3.74/95	7.24/184		17.3/65



Tank Mounted Strainers

Specifications

- Flow Range: 0-100 gpm / 0-380 lpm
- Outlet Port Size: 3/8" NPT to 1 1/4" NPT or SAE-8 to SAE-20
- 140 Micron Stainless Steel Mesh
- Steel SAE bushing
- Cast iron NPT bushing
- Operating temperatures to 250°F / 121°C
- Relief valve available

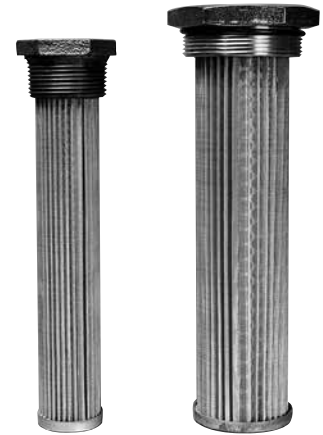

Features

Tank mounted strainers offer easy installation.

Access to reservoir interior is not needed.

You can mount these units through a sidewall or through the tank top and into a standpipe.

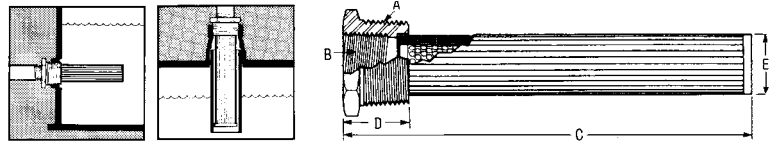

Part No.	Description	Relief Valve Setting	Wire Mesh Size	Dimensions (in/mm)					Screen Area (in ² /cm ²)	Max. Flow (gpm/lpm)
				A	B	C	D	E		
P562270	TM-3-100	n/a	100	3/4" NPT	1/2" NPT	4/102	0.97/25	0.87/22	29/187	3/11
P562274	TM-5-100	n/a	100	1" NPT	1/2" NPT	5.34/136	1.06/27	1.17/30	35/226	5/19
P562275	TM-5-100-RV5	5 psid/0.35 bar	100	1" NPT	1/2" NPT	5.34/136	1.06/27	1.17/30	35/226	5/19
P562256	TM-10-100	n/a	100	1-1/4" NPT	3/4" NPT	8.17/208	1.2/30	1.36/35	64/413	10/38
P562257	TM-10-100-RV5	5 psid/0.35 bar	100	1-1/4" NPT	3/4" NPT	8.17/208	1.2/30	1.36/35	64/413	10/38
P562259	TM-10-60-RV5	5 psid/0.35 bar	60	1-1/4" NPT	3/4" NPT	8.17/208	1.2/30	1.36/35	64/413	10/38
P562260	TM-15-100	n/a	100	1-1/2" NPT	1" NPT	8.2/208	1.22/31	1.66/42	86/555	15/56
P562264	TM-15-100-RV5	5 psid/0.35 bar	100	1-1/2" NPT	1" NPT	8.2/208	1.22/31	1.66/42	86/555	15/56
P562266	TM-25-100	n/a	100	2" NPT	1-1/4" NPT	9.04/230	1.35/34	2.12/54	125/806	25/94
P562267	TM-25-100-RV5	5 psid/0.35 bar	100	2" NPT	1-1/4" NPT	9.04/230	1.35/34	2.12/54	125/806	25/94
P562271	TM-50-100	n/a	100	3" NPT	2" NPT	9.7/246	1.7/43	3/76	260/1677	50/188
P562272	TM-50-100-RV3	3 psid/0.2 bar	100	3" NPT	2" NPT	9.7/246	1.7/43	3/76	260/1677	50/188
P562273	TM-50-100-RV5	5 psid/0.35 bar	100	3" NPT	2" NPT	9.7/246	1.7/43	3/76	260/1677	50/188
P563306	TM-100-100	n/a	100	4" NPT	3" NPT	11.3/287	1.8/46	4/102	315/2032	100/376
P562255	TM-100-100-RV5	5 psid/0.35 bar	100	4" NPT	3" NPT	11.3/287	1.8/46	4/102	315/2032	100/376
P562253	STM-5-100	n/a	100	1-5/16" -- 12 UN	3/4" -- 16 UN	5.34/136	1.06/27	1.17/30	35/226	5/19
P562254	STM-5-100-RV5	5 psid/0.35 bar	100	1-5/16" -- 12 UN	3/4" -- 16 UN	5.34/136	1.06/27	1.17/30	35/226	5/19
P562247	STM-10-100	n/a	100	1-5/8" -- 12 UN	1-1/16" -- 12 UN	8.17/208	1.2/30	1.36/35	64/413	10/38
P562249	STM-15-100	n/a	100	1-7/8" -- 12 UN	1-5/16" -- 12 UN	8.2/208	1.22/31	1.66/42	86/555	15/56
P562250	STM-15-100-RV5	5 psid/0.35 bar	100	1-7/8" -- 12 UN	1-5/16" -- 12 UN	8.2/208	1.22/31	1.66/42	86/555	15/56
P562251	STM-25-100	n/a	100	2-1/2" -- 12 UN	1-5/8" -- 12 UN	9.04/230	1.35/34	2.12/54	125/806	25/94
P562252	STM-25-100-RV5	5 psid/0.35 bar	100	2-1/2" -- 12 UN	1-5/8" -- 12 UN	9.04/230	1.35/34	2.12/54	125/806	25/94

Diffusers

Specifications

- Perforated Steel
- Cast iron bushings (TMD-tank mount)
- Zinc-plated steel (DFD-return line)
- Operating temperatures to 250°F / 121°C
- Flow Range: 0-450 gpm / 0-1,710 lpm



DFD



TMD

Features

Diffusers are highly effective in reducing aeration, foaming, turbulence and noise caused by return lines. Reservoir baffles can usually be eliminated, provided that the holes in the tube are positioned facing away from the pump suction inlet and below the reservoir oil level. Can be vertically or horizontally mounted with discharge side directed away from suction and preferably toward a tank wall or bottom.

Line Mounted Diffuser (DFD)

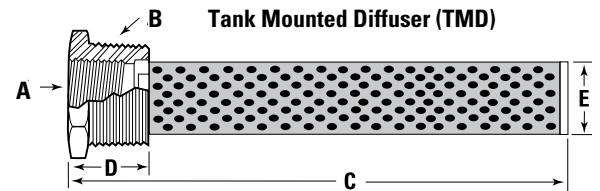
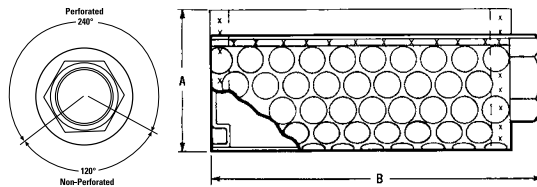

TMD - Tank Mount Diffusers

Part No.	Description	Rated Flow gpm/lpm	Dimension A Pipe Size	Dimension B Pipe Size	Dimensions (in/mm)		
					C	D	E
P562281	TMD-5	5/19	1/2" NPT	1" NPT	5.34/135	1.06/28	1.17/29
P562282	TMD-10	10/38	3/4" NPT	1-1/4" NPT	8.17/207	1.2/30	1.36/34
P562283	TMD-15	15/59	1" NPT	1-1/2" NPT	8.2/208	1.22/31	1.66/42
P562284	TMD-25	25/95	1-1/4" NPT	2" NPT	9.04/229	1.35/34	2.12/53

DFD - Line Mount Diffusers

Part No.	Description	Rated Flow gpm/lpm	Pipe Size	Dimension A (in/mm)	Dimension B (in/mm)
P562287	DFD-30	33/125	3/4" NPT	3.4/86.3	3.0/76
P562288	DFD-60	53/201	1" NPT	3.4/86.3	4.2/107
P562289	DFD-90	93/342	1-1/4" NPT	3.4/86.3	6.5/165
P562290	DFD-120	126/479	1-1/2" NPT	4.5/114.3	6.6/168
P562291	DFD-200	209/794	2" NPT	4.5/114.3	10.3/262
P562292	DFD-250	300/1140	2-1/2" NPT	5.25/133.4	13.0/330
P562293	DFD-300	450/1748	3" NPT	5.25/133.4	15.5/394

Breathers

Breathers are available in a variety of styles, materials and sizes. Breathers provide clean airflow into reservoirs and other storage containers where there is an exchange of air during changing fluid levels. In high moisture sites or applications with large changes in machine environments, breather caps with pressure relief and vacuum breakers limit air exchange and provide a positive suction head at the pump inlet.



Threaded Adapters for Creating Tank Breathers

Part No.	LHA Part No.	Male Pipe Thread	Element Attachment Thread	Length (in/mm)	Material
P173544	GBF-15	3/4" NPT	1"-12 UN	2.50/64	Aluminum
P173545	GBF-50/60	1-1/4" NPT	1-1/2"-16 UN	3.00/76	Aluminum
P562627	GBF-10	3/4" NPT	1-1/8"-16 UN	1.65/42	Steel
P562628	ABGBA	Bayonet Fitting	1-1/8"-16 UN	1.36/35	Technopolymer
P570353	NA	Bayonet Fitting	1-1/2"-16 UN	2.74/70	Technopolymer

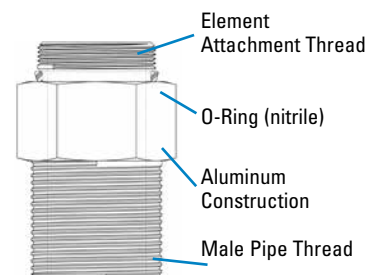

Direct Replacements for Schroeder Breathers

A replacement for Schroeder part ABF-3/10 is available as a breather+adapter set. For other Schroeder replacements and as an alternative on the ABF-3/10, you may purchase adapters and spin-on filters as separate items.

Schroeder Part No.	Donaldson Spin-On Breather + Adapter Set	Adapter	Spin-On Breather
ABF-3/10	P564425	P562627	P564424
ABF-3/10-F	NA	P562628	P564424
MBF-3-M-P20	NA	P173545	P550386
MBF-10-M-P20	NA	P173545	P550388

Replacement for Schroeder ABF3/10

P564425 Spin-On Breather & Adapter
P564424 Spin-On Breather only

Specifications:

Diameter: 3.69" / 93.7mm
Height: 3.6" / 91mm
Threads on adaptor: 3/4"-14 NPT



Spin-On Breather Filters

Part No.	Use with Adapter	Micron Rating	Length (in/mm)	Diameter (in/mm)	Flow (scfm/gpm/lpm)
P564424	P562627 or P562628	10 micron nom.	3.6/91	3.7/94	15/112/421
P556005	P562627 or P562628	10 micron nom.	5.4/137	3.7/94	23/172/647
P551551	P173544	10 micron nom.	5.4/137	3.7/94	23/172/647
P560693	P173544	10 micron abs.	5.4/137	3.7/94	23/172/647
P564357	P173544	5 micron abs.	7.9/200	3.7/94	28/216/812
P179089	P173544	10 micron abs.	7.9/200	3.7/94	28/216/812
P550386	P173545	3 micron nom.	6.7/170	5.0/127	35/262/985
P550250	P173545	3 micron nom.	10.7/272	5.0/127	42/314/1181
P167162	P173545	5 micron abs.	6.7/170	5.0/127	59/440/1654
P165762	P173545	5 micron abs.	10.7/272	5.0/127	64/479/1801
P550388	P173545	10 micron nom.	6.7/170	5.0/127	59/440/1654
P550251	P173545	10 micron nom.	10.7/272	5.0/127	64/479/1801
DBH5875	P173545	10 micron $\alpha_{c(10)} = 1000$	6.7/170	5.0/127	59/440/1654
P165875	P173545	10 micron abs.	6.7/170	5.0/127	59/440/1654
P165876	P173545	10 micron abs.	10.7/272	5.0/127	64/479/1801



T.R.A.P.™ Breather

Flow Rates to:

45 cfm / 1270 lpm

Particulate Removal to:

3 μm

Moisture Removal:

Reversible Adsorption



Features

Donaldson breathers with Thermally Reactive Advanced Protection (T.R.A.P.™) provide fast-acting protection for hydraulic reservoirs against airborne moisture and particulate contamination. Donaldson T.R.A.P. technology strip moisture vapor from intake air and expel the moisture back to the atmosphere. Moisture is prevented from entering and is actually “pumped” out with each flow cycle. T.R.A.P. media regenerates its water-holding capacity, which leads to longer service life – 3 to 4 times the life of conventional desiccant breathers.

- Electronic Indicator**
 Actuated by pressure differential, flashes red to indicate changeout is needed. Indicator setting, 1 psid/6.9 kPa. Indicator power source: 3V lithium battery CR2032.
- Mechanical Indicator Kits**
 Install kit between reservoir and T.R.A.P. breather. Lock-up style indicator with manual reset. Highly visible, bright red band shows when restriction limit is reached. Indicator setting, 20" H2O/5.0 kPa.
- Oil Splash and Mist Containment**
 Keeps oil inside reservoir.
- Easy To Install**
 Lightweight—simply hand tighten.
- Rugged Design**
 Effective to -40°F (-40°C). Robust housing protects media. Because it withstands high vibration, T.R.A.P. is suitable for both stationary and mobile applications.

Operating Temperatures
<ul style="list-style-type: none"> -40°F to 200°F / -40°C to 93°C Intermittent operation to 250°F / 121°C
Particulate Removal Efficiency
<ul style="list-style-type: none"> 3 μm at 97%
Connection Sizes
<ul style="list-style-type: none"> 1" and 3/4" NPT, 3/4" BSP Bayonet 1/4" and 3/8" NPT, 9/16"-18UN
Flow Rates
<ul style="list-style-type: none"> 45 cfm / 1274 lpm 25 cfm / 708 lpm 3 cfm / 85 lpm
Indicator Setpoint
<ul style="list-style-type: none"> 1 psid / 6.9 kPa

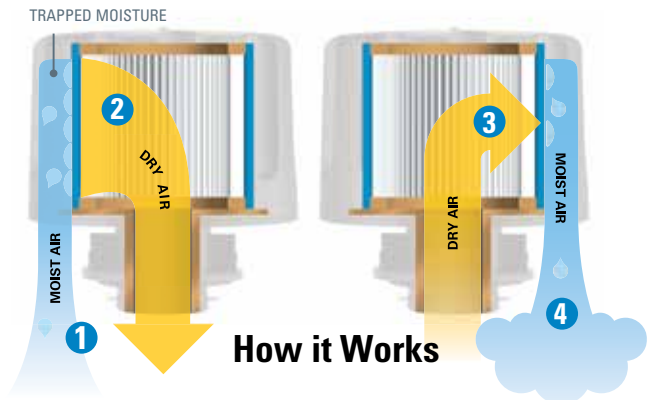

- INTAKE CYCLE (INHALATION)**
- The circuit “breathes in” air containing moisture vapor.
 - The T.R.A.P. breather strips moisture and particulate from the incoming air, allowing only clean, dry air to enter the circuit.
- OUTFLOW CYCLE (EXHALATION)**
- During the “exhalation” cycle, the T.R.A.P. breather allows unrestricted airflow outward.
 - The outflow of dry air picks up the moisture collected by the T.R.A.P. breather during intake, and “blows it back out” – fully regenerating the breather’s water-holding capacity.

Self-Regenerating T.R.A.P. Breather Choices

• Refer to the FIK section for additional T.R.A.P. breather options specific to those assembly models only.

T.R.A.P. Breather Sizing

Trap Model	Hydraulic System (gal/l)	In-plant Lube (gal/l)	Outside (gal/l)
Standard	100/375	500/1875	250/938
Metal	40/150	200/750	100/375
Mini	4/15	20/75	10/38

Part No.	Connection	Maximum Flow (cfm/lpm)	Indicator	Moisture Removal
Standard ABS Plastic Breathers with Oil/Splash Containment				
P566151*	1" NPT	45/1274	opt mechanical	Yes indicator kit
P564669	1" NPT	45/1274	electronic**	Yes
P566156	Bayonet	45/1274	none	Yes
P565616	Bayonet	45/1274	electronic**	Yes
Medium Epoxy Coated Steel Breathers with Oil/Splash Containment				
P565857*	3/4" NPT	25/708	opt mechanical	Yes indicator kit
P565858	Bayonet	25/708	none	Yes
P566037	3/4" BSP	25/708	none	Yes
P575077	Bayonet with Lock Tab	25/708	none	Yes



Standard



Medium Metal



Mini

**LED indicators not rated for fuel.

Part No.	Connection	Maximum Flow (cfm/lpm)	Indicator	Moisture Removal
Mini Nylon Breathers with Oil/Splash Containment				
P566174	9/16"-18 UNF	3/85	none	Yes
P567390	3/8" NPT	3/85	none	Yes
P567392	1/4" NPT	3/85	none	Yes

Part No.	Connection	Maximum Flow (cfm/lpm)	Indicator	Moisture Removal
Mini Particulate Only Breathers with Oil Splash Containment				
P567932	3/8" NPT	3/85	none	No
P567933	1/4" NPT	3/85	none	No

Part No.	Connection	Indicator
*Mechanical Indicator Kit - For use with P566151 & P565857 (*requires customer-supplied 3/4"x1" NPT reducer bushing)		
P566168	1" NPT coupling	20" H2O/5 kPa trip point

Part No.	Description	Connection
Bayonet Style Filler Basket - For use with bayonet style T.R.A.P. Breathers		
P566321	3" Stainless steel basket	6-bolt 2.81/71.4 circle
P575080	6" Stainless steel basket with Lock Tab	6-bolt 2.81/71.4 circle
P563874	4" Nylon Basket	6-bolt 2.81/71.4 circle
P563453	6" Stainless steel basket	6-bolt 2.81/71.4 circle

T.R.A.P. Performance Data

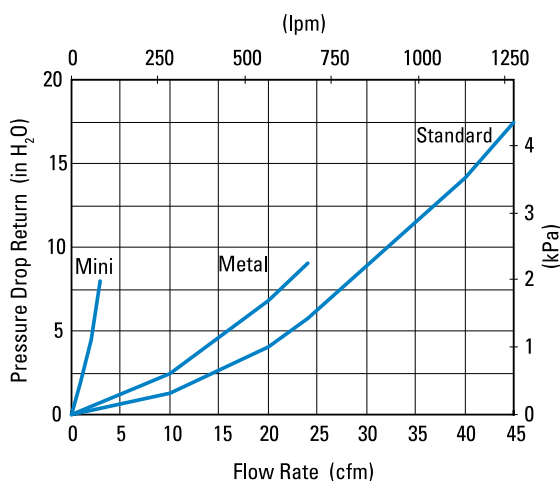

Activation Instructions for T.R.A.P. Breathers with Electronic Indicator

The T.R.A.P. breather has a service indicator that will indicate when it is time to replace the T.R.A.P. This indicator should be activated before the T.R.A.P. is put into service. Before the T.R.A.P. is activated, it is in a sleep mode to conserve the battery. The T.R.A.P. can remain in a sleep mode for over 6 months without detriment to the battery. While in sleep mode, the LED light will not flash until it is activated.

Activation

- 1 Remove the T.R.A.P. from the box and turn it upside down - with the neck and thread up.
- 2 Using a forefinger, insert into the neck of the T.R.A.P. and press on the plastic screen until the LED light begins to flash. The light will flash three times with a shortflash followed by a long flash and then another short flash.
- 3 Release pressure from the switch immediately after the light begins flashing.

The T.R.A.P. is now activated.

Replacement

Replace T.R.A.P. with a new one when the light begins to blink.



T.R.A.P.™ Breather Specifications

Standard **P565616** (electronic indicator) Bayonet connection
P566156 (no indicator version) Bayonet connection
Bayonet connection

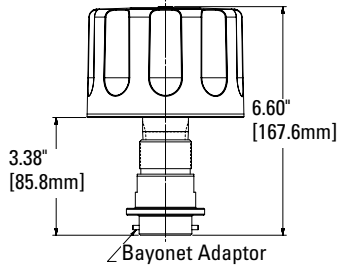

Top View

P564669 (optional mechanical) 1" NPT connection
P566151 (no indicator version) 1" NPT connection

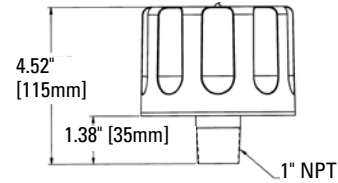

Metal **P565858** Bayonet connection
P575077 Bayonet connection with Lock Tab

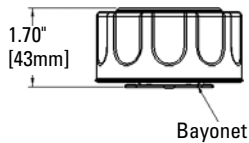

Bayonet



Top View

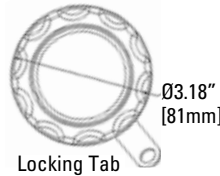

Locking Tab

P565857 (3/4" NPT connection, optional mechanical indicator)
P566037 (3/4" BSP connection)

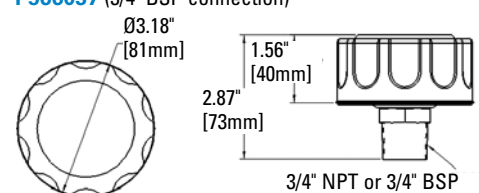

Mini **P566174** 9/16-18 UNF
P567390 3/8" NPT
P567392 1/4" NPT

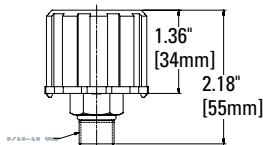

Top View

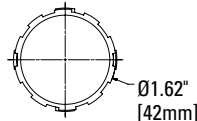

Mechanical Indicator Kit

P566168

Suitable for use with **P566151** and **P565857***
 *Requires additional 3/4" x 1" reducer bushing (supplied by customer)

Top View

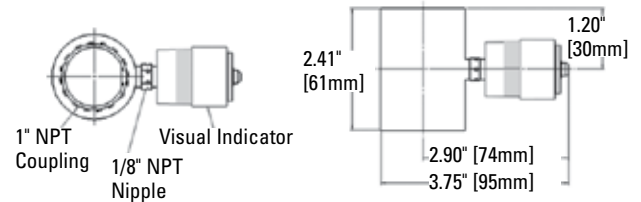

Bayonet Style Filler Basket/Flange Kits

Use with any bayonet style T.R.A.P. Breather

P566321

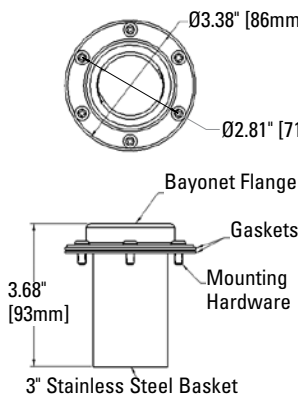

P575080

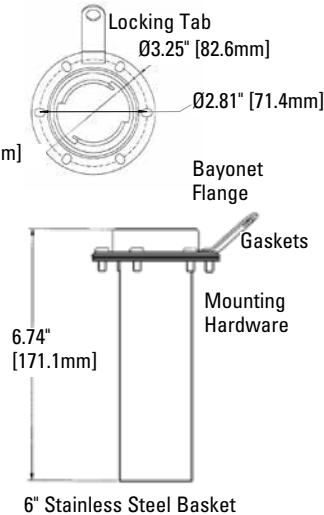

P563874

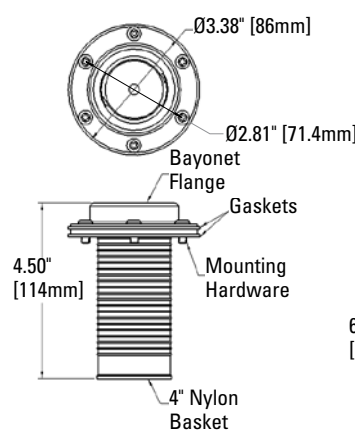

P563453

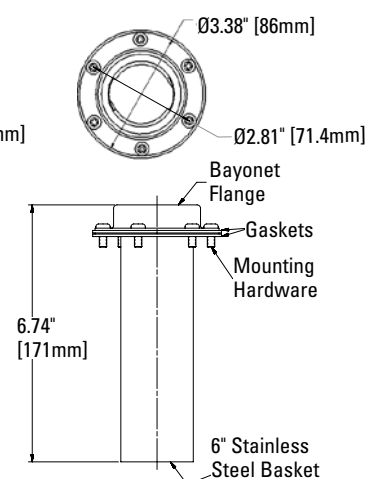

ABS, MBS Series

Specifications

- Chrome plated, epoxy coated or zinc plated steel cap
- Airflow to 30 cfm / 850 lpm
- Compatible with petroleum based fluids
- Temperature to 212°F / 100°C
- 1/2", 3/4" and 1" NPT on ABS
- 1/4" and 3/8" NPT on MBS

Options

- 3, 10 and 40 micron (ABS), 10 and 40 micron (MBS)
- Zinc and epoxy coated weather-proof cap versions

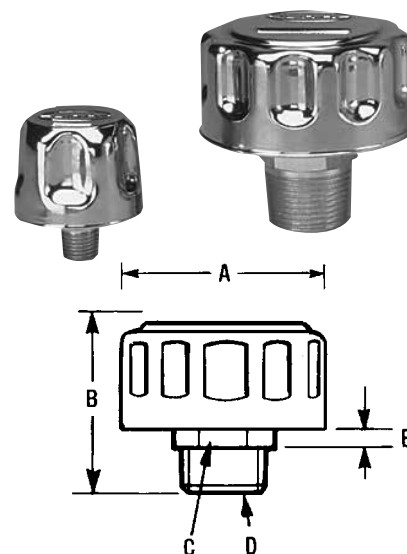

Part No.	Reference	Micron Rating	Airflow Capacity (cfm/lpm)	Dimensions (in/mm)					Finish
				A	B	C	D	E	
P562510	MBS-10-N04	10 µm	10/283	1.85/47	2.0/51	.75/19	1/4" NPT	.2/5	Chrome Plated
P562511	MBS-10-N06	10 µm	10/283	1.85/47	2.0/51	.75/19	3/8" NPT	.2/5	Chrome Plated
P562512	MBS-40-N04	40 µm	10/283	1.85/47	2.0/51	.75/19	1/4" NPT	.2/5	Chrome Plated
P562514	MBS-40-N06	40 µm	10/283	1.85/47	2.0/51	.75/19	3/8" NPT	.2/5	Chrome Plated
P562516	MBS-Z-10-N06	10 µm	10/283	1.85/47	2.0/51	.75/19	3/8" NPT	.2/5	Zinc Plated
P562517	ABS-03-N12	3 µm	30/850	3.15/80	2.8/71	1.18/30	3/4" NPT	.5/13	Chrome Plated
P562518	ABS-10-B12	10 µm	30/850	3.15/80	2.8/71	1.18/30	3/4" BSP	.5/13	Chrome Plated
P562519	ABS-10-N08	10 µm	30/850	3.15/80	2.8/71	1.18/30	1/2" NPT	.5/13	Chrome Plated
P562520	ABS-10-N12	10 µm	30/850	3.15/80	2.8/71	1.18/30	3/4" NPT	.5/13	Chrome Plated
P562521	ABS-10-N16	10 µm	30/850	3.15/80	2.8/71	1.18/30	1" NPT	.5/13	Chrome Plated
P562522	ABS-40-N08	40 µm	30/850	3.15/80	2.8/71	1.18/30	1/2" NPT	.5/13	Chrome Plated
P562523	ABS-40-N12	40 µm	30/850	3.15/80	2.8/71	1.18/30	3/4" NPT	.5/13	Chrome Plated
P562524	ABS-40-N16	40 µm	30/850	3.15/80	2.8/71	1.18/30	1" NPT	.5/13	Chrome Plated
P562525	ABS-W-03-N12	3 µm	30/850	3.15/80	2.8/71	1.18/30	3/4" NPT	.5/13	Epoxy Coated Black
P562526	ABS-W-10-N08	10 µm	30/850	3.15/80	2.8/71	1.18/30	1/2" NPT	.5/13	Epoxy Coated Black
P562527	ABS-W-10-N12	10 µm	30/850	3.15/80	2.8/71	1.18/30	3/4" NPT	.5/13	Epoxy Coated Black
P562528	ABS-W-10-N16	10 µm	30/850	3.15/80	2.8/71	1.18/30	1" NPT	.5/13	Epoxy Coated Black
P563901	ABS-W-40-B12	40 µm	30/850	3.15/80	2.8/71	1.18/30	3/4" BSP	.5/13	Epoxy Coated Black
P562529	ABS-W-40-N12	40 µm	30/850	3.15/80	2.8/71	1.18/30	3/4" NPT	.5/13	Epoxy Coated Black
P562530	ABS-W-40-N16	40 µm	30/850	3.15/80	2.8/71	1.18/30	1" NPT	.5/13	Epoxy Coated Black
P562532	ABS-Z-40-N08	40 µm	30/850	3.15/80	2.8/71	1.18/30	1/2" NPT	.5/13	Zinc Plated
P562533	ABS-Z-40-N12	40 µm	30/850	3.15/80	2.8/71	1.18/30	3/4" NPT	.5/13	Zinc Plated



PBS Series Pressure Filler Breather Cap - Screw In Style

Specifications

- Chrome plated or epoxy coated steel cap
- Air intake valve opens at 0.435 psi/3 kPa
- Compatible with petroleum based fluids
- Temperature range:
-22°F to +240°F / -30°C to 115°C
- Nitrile gaskets standard
- 10 and 40 micron available
- Relief valve settings at 5 psi / 0.34 bar or 10 psi / 0.69 bar full rate flow



5 PSI/0.34 bar

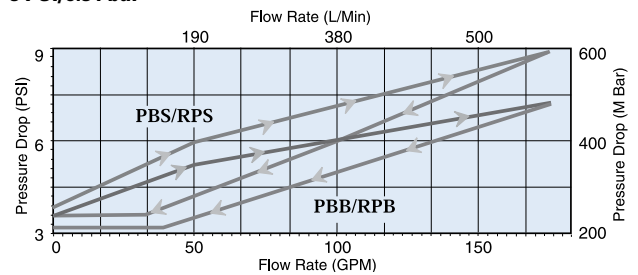

10 PSI/0.69 bar

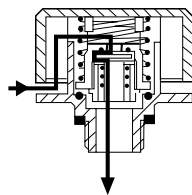
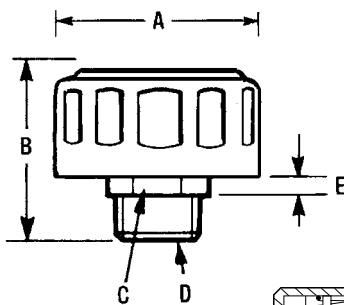
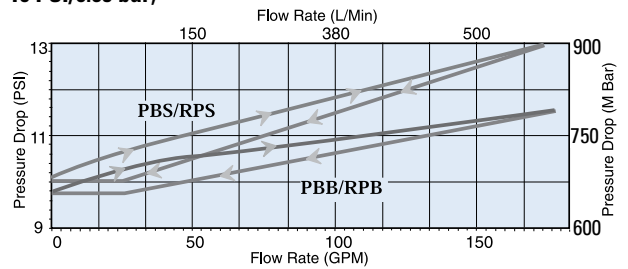

Air intake in the reservoir through vacuum breaker when pressure decreases (.435 psi)

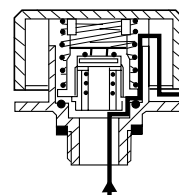

Venting to atmosphere through relief valve to maintain a 5 or 10 psi full rated flow

Part No.	Description	Micron Rating	Airflow Capacity (cfm/lpm)	Relief Valve Setting (psi/bar)	Dimensions (in/mm)					Finish
					A	B	C	D	E	
P563362	PBS-10-10-N12	10 μm	30/850	10/0.69	3.15 / 80	2.8 / 71	1.18 / 30	3/4" NPT	.5 / 13	Chrome Plated
P563363	PBS-10-10-N16	10 μm	30/850	10/0.69	3.15 / 80	2.8 / 71	1.18 / 30	1" NPT	.5 / 13	Chrome Plated
P563365	PBS-10-5-N12	10 μm	30/850	5/0.34	3.15 / 80	2.8 / 71	1.18 / 30	3/4" NPT	.5 / 13	Chrome Plated
P563366	PBS-10-5-N16	10 μm	30/850	5/0.34	3.15 / 80	2.8 / 71	1.18 / 30	1" NPT	.5 / 13	Chrome Plated
P563367	PBS-40-10-N12	40 μm	30/850	10/0.69	3.15 / 80	2.8 / 71	1.18 / 30	3/4" NPT	.5 / 13	Chrome Plated
P563368	PBS-40-5-N12	40 μm	30/850	5/0.34	3.15 / 80	2.8 / 71	1.18 / 30	3/4" NPT	.5 / 13	Chrome Plated
P563369	PBS-40-5-N16	40 μm	30/850	5/0.34	3.15 / 80	2.8 / 71	1.18 / 30	1" NPT	.5 / 13	Chrome Plated
P563370	PBS-W-10-5-N12	10 μm	30/850	5/0.34	3.15 / 80	2.8 / 71	1.18 / 30	3/4" NPT	.5 / 13	Epoxy Coated Black
P563371	PBS-W-40-10-N12	40 μm	30/850	10/0.69	3.15 / 80	2.8 / 71	1.18 / 30	3/4" NPT	.5 / 13	Epoxy Coated Black
P563372	PBS-W-40-5-N12	40 μm	30/850	5/0.34	3.15 / 80	2.8 / 71	1.18 / 30	3/4" NPT	.5 / 13	Epoxy Coated Black



Filler Breather Caps

Specifications

- High impact-resistant technopolymer construction
- Cap diameters 1.22" / 31mm, 1.65" / 42mm, 2.24" / 57mm and 2.75" / 70mm
- Compatible with petroleum and water based fluids
- Temperature range -22°F to +240°F / -30°C to +115°C
- Displacements to 250 gpm / 946 lpm without baffle
- Displacements to 144 gpm / 547 lpm with anti-splash baffle



CPS / DPS / LPS

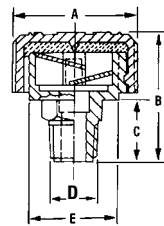

BPS / RPS

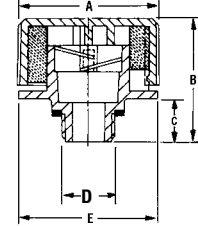

Part No.	Description	Micron Rating	Airflow Capacity (cfm/lpm)	Relief Valve Setting (psi/bar)	Dimensions (in/mm)				
					A	B	C	D	E
P562494	DPS-40-N04	40 µm	4.9/139	n/a	1.65/42	1.54/52	.67/18	1/4" NPT	1.2/30
P562495	DPS-40-N04-A	40 µm	2.1/59	n/a	1.65/42	2.05/52	.71/18	1/4" NPT	1.2/30
P563614	DPS-40-N06	40 µm	11.7/331	n/a	1.65/42	2.05/52	.71/18	3/8" NPT	1.2/30
P562497	DPS-40-N06-A	40 µm	5/142	n/a	1.65/42	2.05/52	.71/18	3/8" NPT	1.2/30
P562501	DPS-40-N08	40 µm	11.7/331	n/a	1.65/42	2.05/52	.71/18	1/2" NPT	1.2/30
P562502	DPS-40-N12	40 µm	12.5/354	n/a	1.65/42	2.05/52	.71/18	3/4" NPT	1.2/30
P562503	DPS-40-N12-A	40 µm	5.4/153	n/a	1.65/42	2.05/52	.71/18	3/4" NPT	1.2/30
P562483	CPS-40-N12	40 µm	27/765	n/a	2.24/57	1.85/47	.87/22	3/4" NPT	1.53/39
P562484	CPS-40-N12-A	40 µm	13.5/382	n/a	2.24/57	1.85/47	.87/22	3/4" NPT	1.53/39
P562480	BPS-10-N12-A	10 µm	19.3/547	n/a	2.75/70	2.48/63	.83/21	3/4" NPT	2.68/68
P562481	BPS-40-N12	40 µm	33.4/946	n/a	2.75/70	2.48/63	.83/21	3/4" NPT	2.68/68
P562482	BPS-40-N12-A	40 µm	19.3/547	n/a	2.75/70	2.48/63	.83/21	3/4" NPT	2.68/68
P562492	RPS-40-5-N12	40 µm	30/850	5/0.34	2.75/70	2.48/63	.83/21	3/4" NPT	2.68/68

* -A = anti-splash

Part No.	Description	Micron Rating	Airflow Capacity (cfm/lpm)	Dimensions (in/mm)				Comment
				A	B	C	D	
P562476	ABO-10	10 µm	30/850	2.75/70	1.5/39	.25/7	1.77/45	Fits over 1.50" OD tube
P562477	ABO-40	40 µm	30/850	2.75/70	1.5/39	.25/7	1.77/45	Fits over 1.50" OD tube

ABO

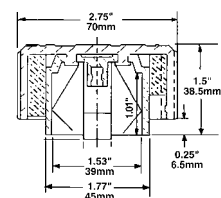



Filler Breather Assemblies

Features

- Removable 500 µm mesh strainer. (Except model P171848, which has a non-removable strainer.)
- 10 µm air breather/filter.
- Models P171855 & P171848 include drilled flanges with attaching screws.

How it Works

As fluid levels rise and fall inside the reservoir, air flows in and out through the strainer and breather as shown below. The breather filter inside the cap removes contaminants as small as 10 µm from the air to keep airborne contaminant from entering the fluid. The strainer removes large particles from fluid as it is added to the reservoir.

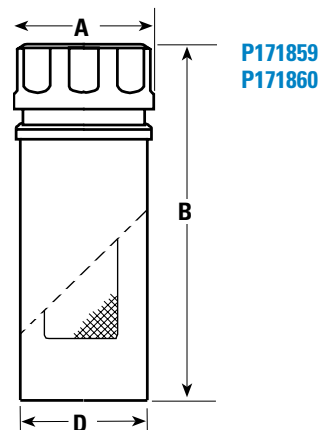
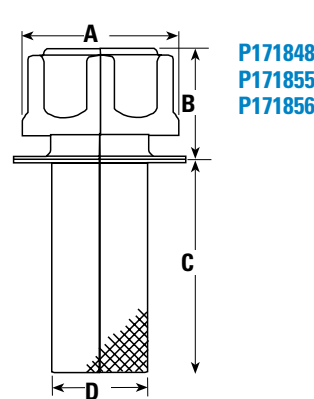
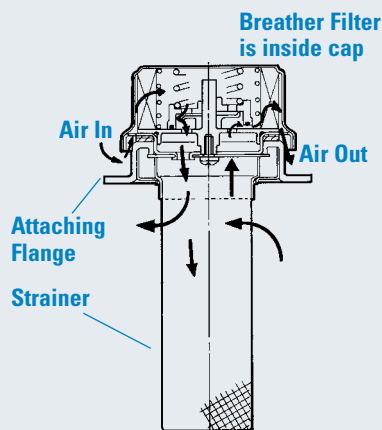

Filler Breather Specifications

Part No.	FLANGE SPECIFICATIONS				Flow (gpm/lpm)	FILLER BREATHER SPECIFICATIONS			
	Outer Dia. (in/mm)	No. of Holes	Hole Dia. (in/mm)	Bolt Circle		A	B	C	D
						Dimensions (in/mm)			
P171848	2.01/51	3	.22/5.5	1.61/41	70/270	1.81/45	1.38/35	2.48/63	1.1/28
P171855	3.31/84	6	.22/5.5	2.88/73	124/470	2.76/70	1.81/46	3.94/100	1.5/38
P171856	3.31/84	n/a	n/a		124/470	2.76/70	1.81/46	3.94/100	1.15/38
P171859		n/a - weldable			124/470	2.76/70	7.09/180	2.50/64	
P171860 *		n/a - weldable			124/470	2.76/70	7.09/180	2.50/64	

* For pressurized reservoirs at 5.8 psi/0.4 bar relief pressure.

Filler Cap Only (Replacement)

P173292 --- fits P171855, P171856, P171859

P173364 for pressurized reservoir --- fits P171860



ABB Series Filler Breathers - Bayonet Style

Specifications

- Chrome plated, epoxy coated or zinc plated steel caps
- Airflow to 30 cfm / 850 lpm
- Compatible with petroleum based fluids
- 30 mesh technopolymer basket
- Self tapping screws for flange mount
- Cork gaskets
- 3, 10, or 40 micron



30 MESH STAINLESS STEEL BASKETS

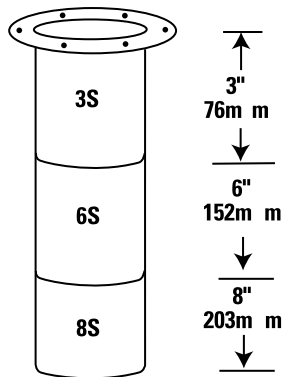

INNER GUARDS

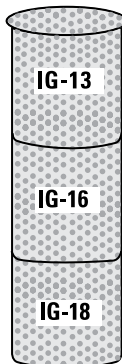

LOCKING TABS (AB ONLY)

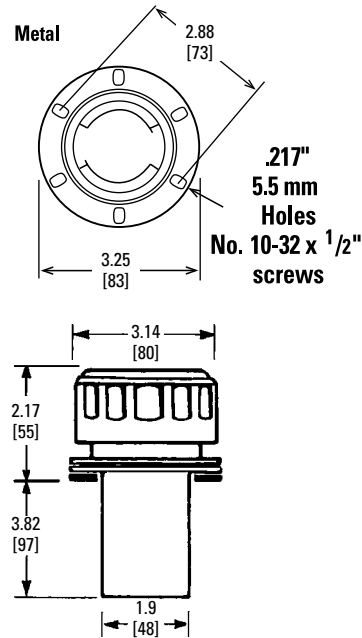
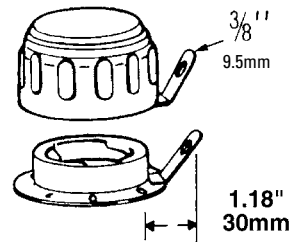

Part No.	Reference	Features	Micron Rating	Finish
P562611	ABB-W-10-3S	3" Stainless basket	10 µm	Epoxy coated, black
P562612	ABB-W-10-3S-LT	3" Stainless basket, lock tab	10 µm	Epoxy coated, black
P562614	ABB-W-10-N	Nylon basket	10 µm	Epoxy coated, black
P562616	ABB-W-10-N-R	Nylon basket, nitrile gasket	10 µm	Epoxy coated, black
P562618	ABB-W-40-3S	3" Stainless basket	40 µm	Epoxy coated, black
P562619	ABB-W-40-6S	6" Stainless basket	40 µm	Epoxy coated, black
P562620	ABB-W-40-N	Nylon basket	40 µm	Epoxy coated, black
P562623	ABB-Z-40-3S	3" Stainless basket	40 µm	Zinc plated
P562624	ABB-Z-40-3S-LT	3" Stainless basket, lock tab	40 µm	Zinc plated
P562625	ABB-Z-40-N	Nylon basket	40 µm	Zinc plated
P562626	ABB-Z-40-N-R	Nylon basket, nitrile gasket	40 µm	Zinc plated

Side Mount

P563609 Side Mount Kit
 Can be used with all Bayonet and Threaded Flange Breathers (except MBB & Pressurized Breathers). Maximum torque for fastening 112 in. lbs. with washers.

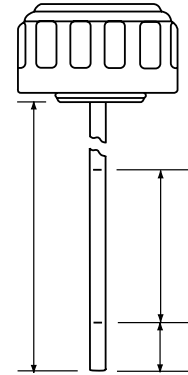
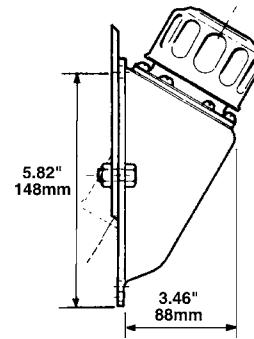

Dipsticks available for some models. See Features section on assembly tables.

Chrome ABB Series Filler Breathers - Bayonet Style

Airflow to 30 cfm/850 lpm

Part No.	Description	Features	Micron Rating
P562573	ABB-03-N	Nylon basket	3 µm
P562574	ABB-10	Flange, screws & gasket, no basket	10 µm
P562575	ABB-10-3S	3" Stainless basket	10 µm
P562576	ABB-10-3S-LT	3" Stainless basket, Lock tab	10 µm
P562577	ABB-10-3S-R	3" Stainless basket, nitrile gasket	10 µm
P562578	ABB-10-3S-SMB	3" Stainless basket, side mount kit	10 µm
P562579	ABB-10-6S	6" Stainless basket	10 µm
P562580	ABB-10-6S-LT	6" Stainless basket, Lock tab	10 µm
P562581	ABB-10-6S-R	6" Stainless basket, nitrile gasket	10 µm
P562582	ABB-10-8S	8" Stainless basket	10 µm
P562584	ABB-10-N	Nylon basket	10 µm
P562585	ABB-10-N-LT	Nylon basket, Lock tab	10 µm
P562587	ABB-10-N-R	Nylon basket, nitrile gasket	10 µm
P562589	ABB-40	Flange, screws & gasket, no basket	40 µm
P562590	ABB-40-3S	3" Stainless basket	40 µm
P562592	ABB-40-3S-R	3" Stainless basket, nitrile gasket	40 µm
P562593	ABB-40-3S-SMB	3" Stainless basket, side mount kit	40 µm
P562594	ABB-40-6S	6" Stainless basket	40 µm
P562595	ABB-40-6S-D	6" Stainless basket, dipstick	40 µm
P562596	ABB-40-6S-LT	6" Stainless basket, Lock tab	40 µm
P562598	ABB-40-8S	8" Stainless basket	40 µm
P562599	ABB-40-8S-D	8" Stainless basket, dipstick	40 µm
P562601	ABB-40-CWOF	Cap only	40 µm
P562602	ABB-40-LT	Lock tab, no basket	40 µm
P562603	ABB-40-N	Nylon basket	40 µm
P562605	ABB-40-N-LT	Nylon basket, Lock tab	40 µm
P562608	ABB-40-N-R	Nylon basket, nitrile gasket	40 µm
P562609	ABB-40-N-SMB	Nylon basket, side mount kit	40 µm

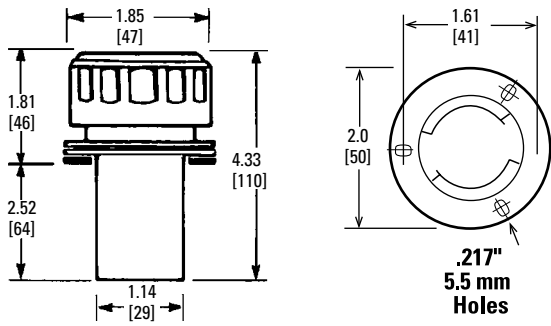

Mini Filler Breather

Part No.	Description	Micron Rating	Airflow Capacity (cfm/lpm)	Finish
P562561	MBB-10-N	10 μm	10/283	Chrome
P562562	MBB-40-N	40 μm	10/283	Chrome

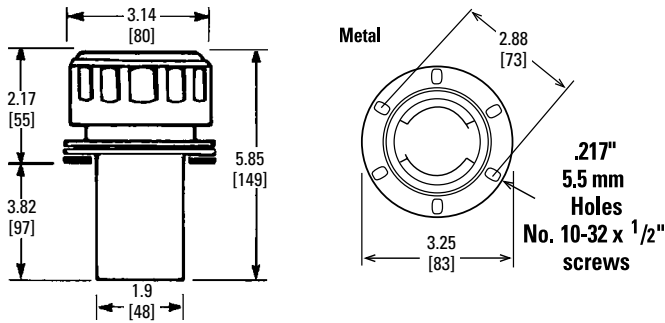

Non-Vent Filler Cap, Bayonet

Part No.	Description	Feature	Finish
P562563	NVB-00-3S	Filler Cap Assembly with 3" Stainless Basket	Chrome
P562564	NVB-00-N	Filler Cap Assembly with Nylon Basket	Chrome
P562565	NVB-W-00-8S	Filler Cap Assembly with 8" Stainless Basket	Epoxy coated, Black



Filler Breathers

Specifications

- High impact black technopolymer
- Temperature range
-22°F to +240°F / -30°C to +115 °C
- 2.75" diameter cap
- Available with bayonet or threaded flange
- Airflow to 30 cfm / 850 lpm
- Compatible with petroleum and water based fluids
- 30 mesh technopolymer basket

Options

- Dipstick 3" / 76mm, 6" / 152mm and 8" / 203mm stainless steel baskets

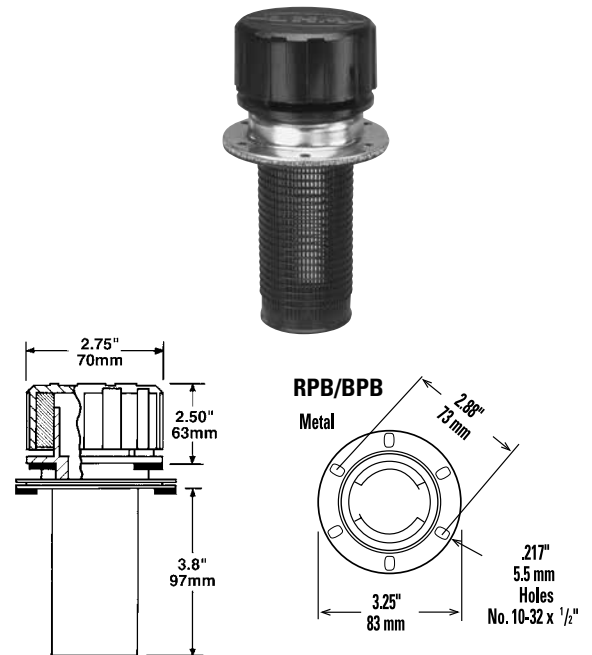

5 PSI/0.34 bar

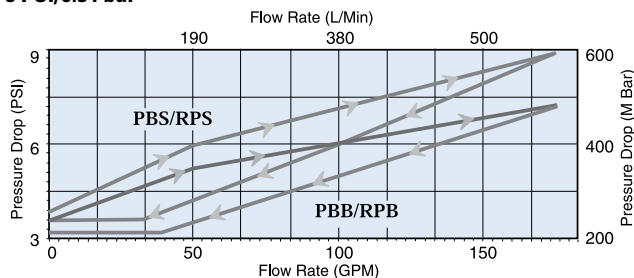

10 PSI/0.69 bar

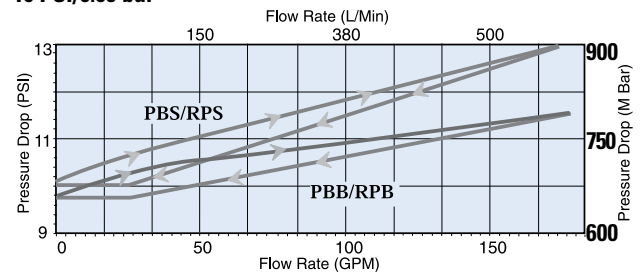

Bayonet Style (RPB) (BPB)

Part No.	Description	Feature	Micron Rating	Airflow Capacity (cfm/lpm)	Relief Valve Setting (psi/bar)
P562554	RPB-40-5-3S	3" Stainless Basket	40 µm	30/850	5/0.34
P562555	RPB-40-5-6S	6" Stainless Basket	40 µm	30/850	5/0.34
P562556	RPB-40-5-N	Nylon Basket	40 µm	30/850	5/0.34
P562536	BPB-10-N-A	Breather	10 µm	30/850	N/A
P562537	BPB-40-3S	Breather with 3" Steel Basket	40 µm	30/850	N/A
P562538	BPB-40-3S-A	Breather	40 µm	30/850	N/A
P562539	BPB-40-6S-D	Filler Breather with Dip Stick	40 µm	30/850	N/A
P562541	BPB-40-N	Breather	40 µm	30/850	N/A
P562542	BPB-40-N-A	Breather	40 µm	30/850	N/A
P562544	BPB-40-N-SMB	Breather with Side Mount Kit	40 µm	30/850	N/A



PBB Series Pressure Filler Breather Cap - Bayonet Style

Specifications

- Chrome plated, epoxy coated or zinc plated steel cap
- Air intake valve opens at 0.435 psi / 3 kPa
- Compatible with petroleum based fluids
- Temperature range
-22°F to +240°F / -30°C to 115°C
- Nitrile gaskets standard
- 10 and 40 micron available
- Relief valve settings at 5 or 10 psi / 0.34 or 0.69 bar full rate flow



5 psi/0.34 bar

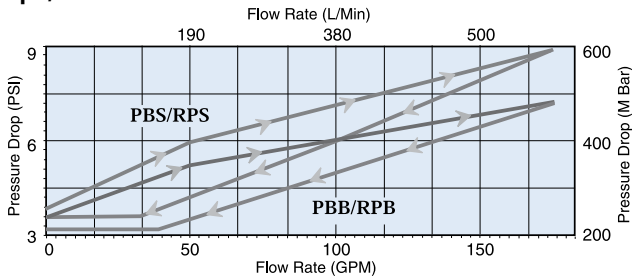

10 psi/0.69 bar

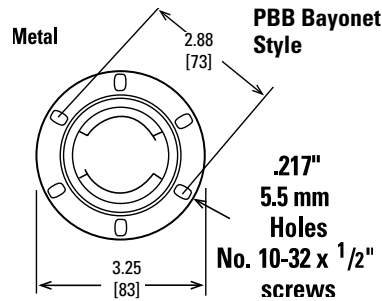
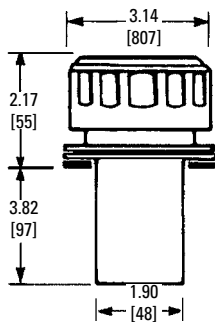
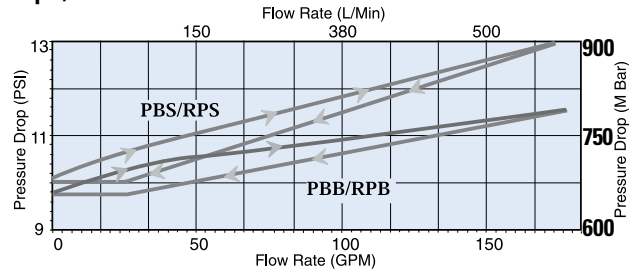



PBB Series Pressure Filler Breather Cap - Bayonet Style

Part No.	Description	Feature	Micron Rating	Airflow Capacity (cfm/lpm)	Relief Valve Setting (psi/mm)	Finish
P563346	PBB-10-5-3S	3" Stainless Basket	10 µm	30/850	5/0.34	Chrome
P563347	PBB-10-5-6S	6" Stainless Basket	10 µm	30/850	5/0.34	Chrome
P563348	PBB-10-5-N	Nylon Basket	10 µm	30/850	5/0.34	Chrome
P563349	PBB-10-5-N-LT	Nylon Basket, Lock Tab	10 µm	30/850	5/0.34	Chrome
P563350	PBB-40-10-N	Nylon Basket	40 µm	30/850	10/0.69	Chrome
P563351	PBB-40-5	Flange, Screws & Gasket, No Basket	40 µm	30/850	5/0.34	Chrome
P563352	PBB-40-5-3S	3" Stainless Basket	40 µm	30/850	5/0.34	Chrome
P563353	PBB-40-5-6S	6" Stainless Basket	40 µm	30/850	5/0.34	Chrome
P563354	PBB-40-5-8S	8" Stainless Basket	40 µm	30/850	5/0.34	Chrome
P563355	PBB-40-5-N	Nylon Basket	40 µm	30/850	5/0.34	Chrome
P563356	PBB-W-10-5-N	Nylon Basket	10 µm	30/850	5/0.34	Epoxy Coated, Black
P563358	PBB-W-40-5-3S	3" Stainless Basket	40 µm	30/850	5/0.34	Epoxy Coated, Black
P563361	PBB-Z-10-5-N	Nylon Basket	10 µm	30/850	5/0.34	Zinc Plated
P563326		3" Stainless Basket Only				
P563465		6" Stainless Basket Only				
P563466		8" Stainless Basket Only				
P563322		4" Nylon Basket Only				

5 PSI/0.34 bar

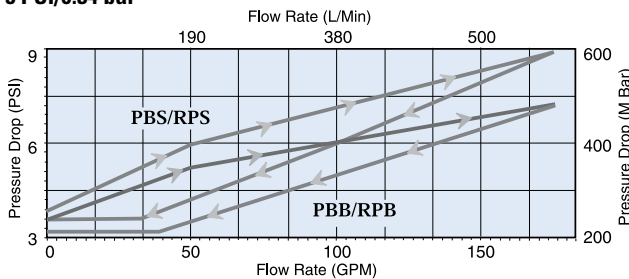

10 PSI/0.69 bar

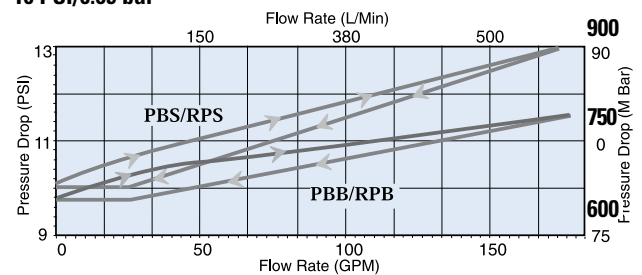

Weld Risers for Filler Breathers

Part No.	Description	Height (in/mm)
P562668	WR-5565	1/25.4



Features

- Steel stamped construction
- Predrilled holes align with standard breather tank flanges
- Provides for easy installation of filler breathers

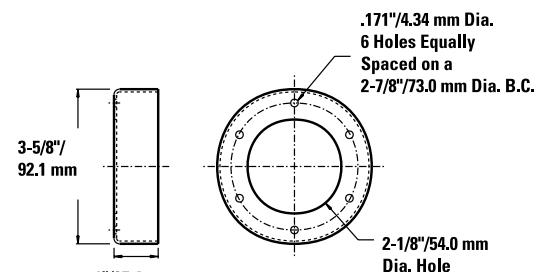



Reservoir Air Dryer

Water/moisture in fluid tanks and reservoirs is a big problem. It creates corrosion, pump cavitation, viscosity changes, additive dropout, oxidation and a host of other major system issues. Our new Reservoir Air Dryer removes damaging water, while eliminating the need to continually replace conventional desiccant breathers, or to dry fluids with vacuum dehydration units.

How it works. The Reservoir Air Dryer combats ambient ingress of moisture by introducing a steady flow of clean, dry air to the reservoir/tank. This flow of air keeps the relative humidity low in the headspace, driving moisture from the fluids and preventing condensation.

Easy Installation. With no electrical hookups, installation is easy. Just connect compressed air to the inlet and the outlet to the top of the reservoir. A coalescing pre-filter (the only part that needs servicing – takes seconds to replace) and outlet regulator are pre-installed.

Don't Forget The T.R.A.P.™ When you combine the Reservoir Air Dryer with a T.R.A.P. Breather – the complete system keeps moisture and contamination out, even if fluid flow rate out of the tank surpasses the Reservoir Air Dryer flow rate into the tank. The Reservoir Air Dryer also regenerates the T.R.A.P. Breather, increasing life and reducing the total cost of ownership.

If you've got a water problem in your reservoirs or storage tanks, or would like to prevent moisture from entering your system, contact your Donaldson distributor or representative for a complete site audit or for more information.





Reservoir Air Dryer

Features

- Designed to operate with Standard Plant Air — instrument quality air is not required!
- Submicron Coalescing Air Filter — collects oil and water droplets and fine particles present in the inlet air.
- Automatic Drain — purges captured liquid. No intervention required
- Visual Indicator — monitors filter condition
- Membrane Air Dryer — reduces the plant air dew point by as much as 150°F (66°C)
- Pressure Regulator — depressurizes the air and ensures that the proper volume of air is introduced into the reservoir
- The Clean Dry Air Sweep dehydrates the reservoir headspace and removes dissolved moisture from exposed oils and fuels*





P575852 Reservoir Air Dryer Specifications	
Efficiency	Reduces dew point as much as 150°F (66°C)*
Fluid Compatibility	Petroleum and Phosphate Ester Fluids, Diesel Fuels
Outlet Flow Volume @100 psi and dew point suppression	0.5 scfm (14.2 slpm) maximum
Inlet Air required @ 100 psi	0.8 scfm (22.7 slpm) maximum
Inlet/Outlet	¼" NPT
Pre-Filter Condition	Visual Indicator (Green/Red)
Pressure Regulator	Dial Gauge
Drain Plug	¼" NPT
Coalescer Drain	Automatic Float Type
Electrical	N/A
Max Working Pressure	116 psi (800 kPa / 8.00 bar)
Max Operating Temperature	125°F (52°C)
Mounting Bracket	3/8" - 16 UN Threaded Nut
Weight	<5 lbs (<3 kg)

*The Reservoir Air Dryer is not recommended for use on gasoline holding tanks, or for the head space of any flammable liquid (Flash Point below 100°F / 38°C)



Reservoir Air Dryer

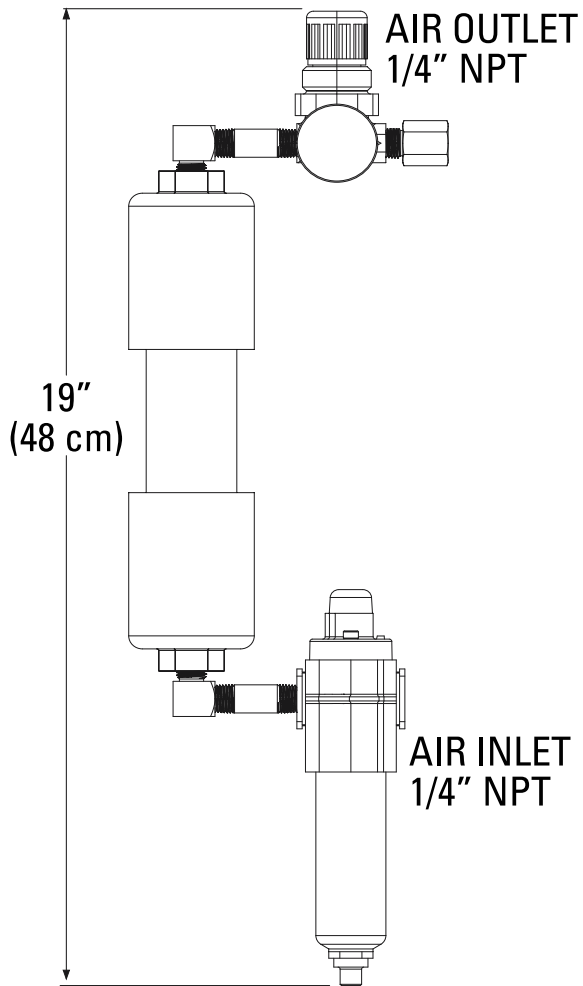
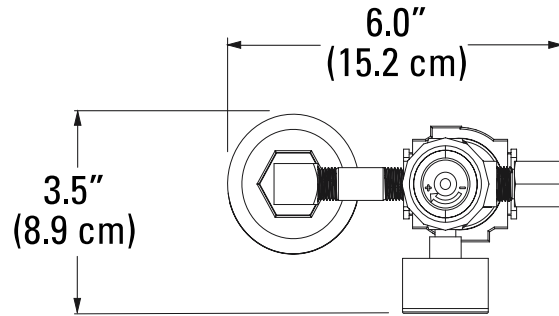



Sight Glasses

Specifications

- Working pressure: 29 psi / 200 kPa / 2 bar
- Transparent polyamid construction
- Shock resistant
- Anodized aluminum reflector
- Operating temperature range:
-20°F to 210°F / -29°C to 100°C
- Nitrile seal
- For use with mineral, petroleum and water-based fluids
- Any contact with alcohol or solvents must be avoided
- Design HFTX

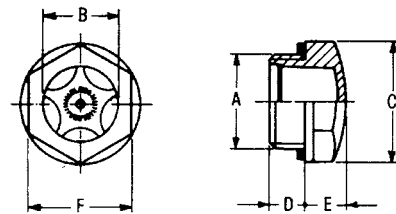

Features

Leak-free sight glasses come in plastic or metal with a variety of threads, seals and lenses. In low visibility areas, prism lens sight glasses are a good solution for quick and accurate readings. In applications involving high pressure or temperatures, steel sight glasses are preferred. Locking nuts provide mounting into sheet metal with minimum thickness and without welding.

Part No.	Description	A -Thread Size	Dimensions (in/mm)				
			B	C	D	E	F
P562423	SG-08-S	3/4" - 16 UN	.51/13	1.02/26	.59/15	.32/8	.87/22
P562427	SG-12-S	1-1/16" - 12 UN	.75/19	1.38/35	.59/15	.39/10	1.18/30



Prism Sight Glasses

Specifications

- Prism lenses: special translucent polyamide technopolymer
- For low light applications
- Body: special black polyamide technopolymer
- Available in 3/4" and 1" NPT sizes
- Resistant to solvents, oils, greases, alkaline acids
- Avoid alcohol and detergents containing alcohol
- Flat nitrile seal

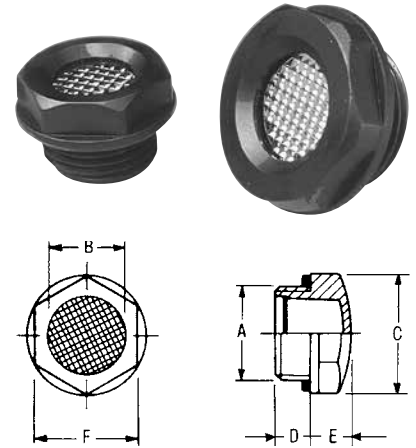

Part No.	Description	A -Thread Size	Dimensions (in/mm)				
			B	C	D	E	F
P562418	PSG-16	1" NPT	0.90/23	1.70/43	0.43/11	0.36/9	1.50/38

Specifications

- Working pressure: 500 psi / 3,450 kPa / 34.5 bar
- All nickel-plated steel construction
- Glass prism lenses hermetically sealed
- Leak-proof service
- Greater mechanical strength
- Easy installation
- Reflects light in the presence of any liquid
- Maximum operating temp. 500°F / 260°C
- Suitable for petroleum and water based fluids

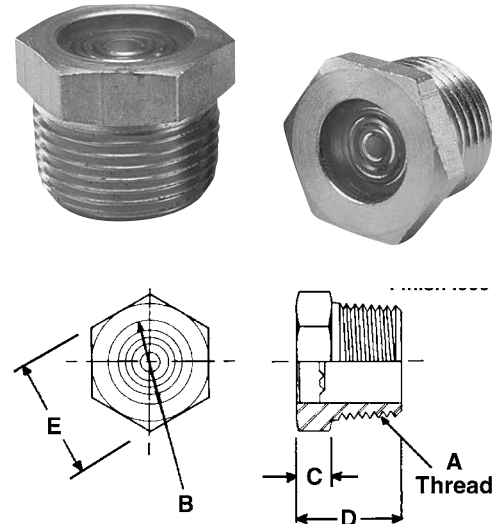

Part No.	Description	A -Thread Size	Dimensions (in/mm)			
			B	C	D	E
P562408	SVM-04	1/4" NPT	0.34/8	0.19/5	0.44/11	0.63/16
P562409	SVM-06	3/8" NPT	0.44/11	0.22/6	0.5/13	0.75/19
P562410	SVM-08	1/2" NPT	0.56/14	0.22/6	0.56/14	0.94/24
P562411	SVM-12	3/4" NPT	0.75/19	0.31/8	0.63/16	1.06/27
P562412	SVM-16	1" NPT	0.94/24	0.31/8	1.25/32	1.38/35
P562413	SVM-20	1-1/4" NPT	1.19/30	0.41/10	0.81/21	1.75/44
P562414	SVM-24	1-1/2" NPT	1.44/37	0.41/10	0.81/21	2.00/51
P562415	SVM-32	2" NPT	1.88/48	0.41/10	0.88/22	2.50/64



Fluid Level Gauges

Specifications

- Steel frame
- Acrylic lens
- Steel zinc plated bolts
- 5" (127mm) mounting bolt centers
- Maximum wall thickness: 1/2" / 12.7mm
- Maximum temperature:
SLT 225°F / 107°C; SLG 180°F / 80°C



SLT-1214
P562433

Features

Donaldson offers a wide variety of fluid level gauges that let you accurately measure fluid levels in your tanks and reservoirs. Gauges are made with transparent lens material and are suitable for lubricants, mineral, petroleum and water based fluids. They offer 180° visibility of fluid level.

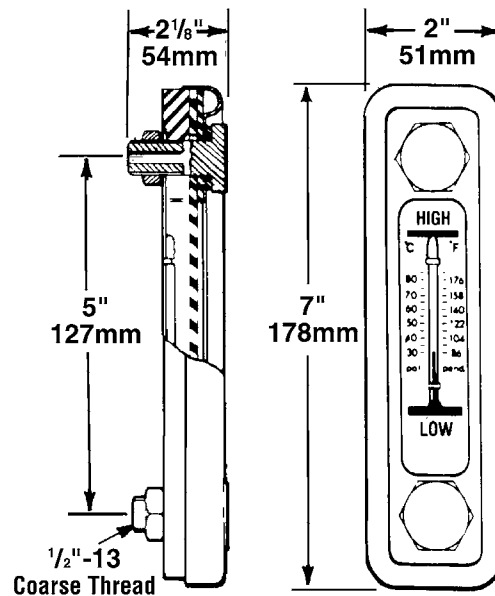

Part No.	Desc.	Feature	Seals
P562433	SLT-1214	5"/127mm Level Gauge w/ Red Thermometer, Chrome Steel Frame	Neoprene

Bolt torque: 15 ft.-lbs./20 Nt-m. Do not exceed 20 ft.-lbs./27 Nt-m.



Fluid Level Gauges

Specifications

- Transparent lens material
- Nitrile seals
- Maximum working pressure for pressurized tanks:
14.5 psi / 1 bar / 100 kPa.
- Oil level and temperature or oil level only
- Temperature scale:
35° to 210°F / 0° to 100°C.

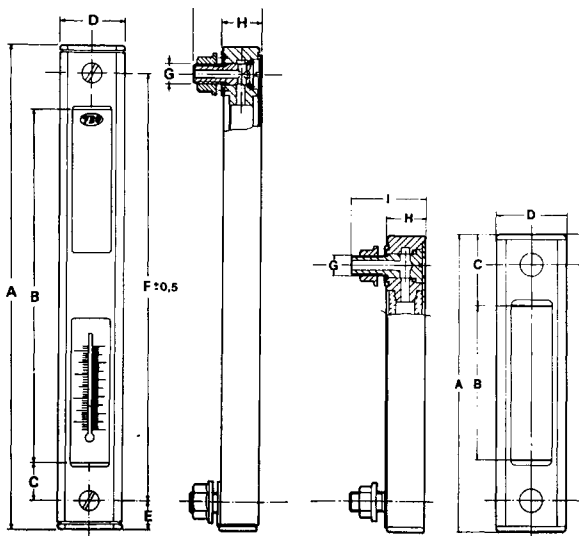

Bolt torque: 10 ft.-lbs/Nt-m.
Inside nut for tightening directly on the tank.
Suggested mounting hole diameter: 11mm or 13mm.

Oil Level/Temperature Gauge Specifications (35° - 210°F / 0° - 100°C)

Part No.	Dimensions (in/mm)								
	A	B	C	D	E	F	G-Thread	H	I
P171920	6.22/158	3.22/82	.89/22.5	1.57/40	.61/15.5	5/127	M12 x 1.75	.78/20	1.57/40
P171922	11.22/285	8.23/209	.89/22.5	1.57/40	.61/15.5	10/254	M12 x 1.75	.78/20	1.57/40

Oil Level Gauge Specifications

Part No.	Dimensions (in/mm)								
	A	B	C	D	E	F	G-Thread	H	I
P171918	6.22/1.58	3.23/82	.89/22.5	1.57/40	.61/15.5	5/127	M12 x 1.75	.78/20	1.57/40
P171913	4.21/107	1.22/31	.89/22.5	1.57/40	.61/15.5	3/76	M10 x 1.5	.78/20	1.57/40



Fluid Level Gauges

Specifications

- Ultrasonically welded polyamide
- Suitable for pressurized reservoirs
- Operating temperature range:
-20°F to 212°F / -29°C to 100°C
- Scale: 32°F to 212°F / 0°C to 100°C
- Maximum wall thickness:
- LG-3 - 1/2" / 12.7mm
- LG-5/LG-10 - 3/8" / 8.3mm
- Nitrile O-Ring seals
- Zinc plated bolts
- Metric bolts

Note: Any contact with alcohol, alcohol-based washing fluids, or petroleum distillates must be avoided. Do not chamfer tank mounting holes. Not for water-glycol applications

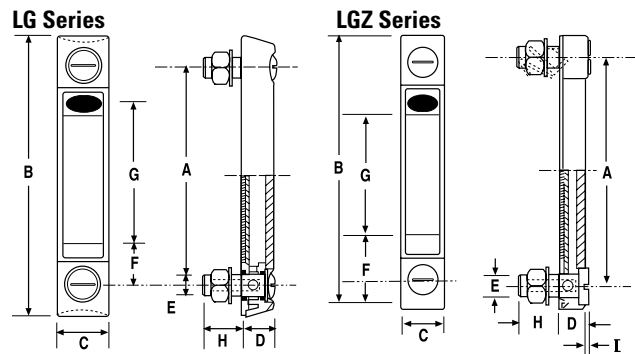

LG-3 FM option E dia. = 0.625 (5/8)
LG-5, 10 FM option E dia. = 0.688 (11/16)

Options:

- 1/2"-13 bolts (LG-5)
- Protective guard (LG-5)
- Fluorocarbon seals
- Red and blue thermometers
- Alcohol resistant version
- Fast mount kit (requires no internal access or threads to mount)

LG-5G Guard

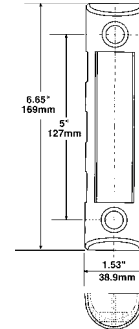

Bolt torque: 9 ft.-lbs./12 Nt-m
(7 ft.-lbs./9.5 Nt-m fast mount)

Fluid Level Gauge Guard (LG-5 Series only)

Part No.	Description	Feature	Dimensions (in/mm)			
			Bolt Center A	B	C	D
P562453	LG-G	5"/127mm Level Gauge Guard	5.00/127	6.65/169	1.53/39	.98/25



Transparent Polyamide Fluid Level Gauges

Level Gauge Choices

Part No.	Description	Feature	Dimensions (in/mm)									
			Bolt Center			Hole Dia.						
			A	B	C	D	E	Bolt Size	F	G	H	I
P562438	LG-3	3" Level Gauge	3.00/76	4.17/106	1.06/27	.63/16	.42/10	M10 x 1.5	.71/18	1.31/33	.83/21	
P562440	LG-3-FM	3" Level Gauge with Fast Mount kit	3.00/76	4.17/106	1.06/27	.63/16	.625/16	M10 x 1.5	.71/18	1.31/33	.83/21	
P562441	LG-3-T	3" Level Gauge with Red Thermometer	3.00/76	4.17/106	1.06/27	.63/16	.42/10	M10 x 1.5	.71/18	1.31/33	.83/21	
P562442	LG-3-TB	3" Level Gauge with Blue Thermometer	3.00/76	4.17/106	1.06/27	.63/16	.42/10	M10 x 1.5	.71/18	1.31/33	.83/21	
P562454	LG-Z-3	3" Level Gauge	3.00/76	3.90/99	.90/22	.57/14.5	.42/10	M10 x 1.5	.70/18	1.30/33.6	.90/23	0.06/1.5
P562444	LG-5	5" Level Gauge	5.00/127	6.34/161	1.22/31	.71/18	.47/12	M12 x 1.75	.90/23	2.91/74	.90/23	
P562445	LG-5-13	5" Level Gauge with 1/2" -13 bolt kit	5.00/127	6.34/161	1.22/31	.71/18	.50/13	1/2" - 13 UNC	.90/23	2.91/74	.90/23	
P562447	LG-5-FM	5" Level Gauge with Fast Mount kit	5.00/127	6.34/161	1.22/31	.71/18	.688/17.5	M12 x 1.75	.90/23	2.91/74	.90/23	
P562448	LG-5-T	5" Level Gauge with Red Thermometer	5.00/127	6.34/161	1.22/31	.71/18	.47/12	M12 x 1.75	.90/23	2.91/74	.90/23	
P562449	LG-5-T-13	5" Level Gauge with Red Thermometer & 1/2"-13 bolt kit	5.00/127	6.34/161	1.22/31	.71/18	.50/13	1/2" - 13 UNC	.90/23	2.91/74	.90/23	
P562450	LG-5-TB	5" Level Gauge with Blue Thermometer	5.00/127	6.34/161	1.22/31	.71/18	.47/12	M12 x 1.75	.90/23	2.91/74	.90/23	
P562451	LG-5-T-FM	5" Level Gauge with Red Thermometer & Fast Mount kit	5.00/127	6.34/161	1.22/31	.71/18	.688/17.5	M12 x 1.75	.90/23	2.91/74	.90/23	
P563913	LG-5-T-G	5" Level Gauge with Red Thermometer & Guard	5.00/127	6.34/161	1.22/31	.71/18	.47/12	M12 x 1.75	.90/23	2.91/74	.90/23	
P562452	LG-5-T-SS	5" Level Gauge with Red Thermometer, Stainless Bolt kit	5.00/127	6.34/161	1.22/31	.71/18	.47/12	M12 x 1.75	.90/23	2.91/74	.90/23	
P562456	LG-Z-5	5" Level Gauge	5.00/127	5.9/150	.90/22	.57/14.5	.47/12	M12 x 1.75	.93/23.5	2.90/73.7	.90/23	0.06/1.5
P562458	LG-Z-5-V	5" Level Gauge with Fluorocarbon seals	5.00/127	5.9/150	.90/22	.57/14.5	.47/12	M12 x 1.75	.93/23.5	2.90/73.7	.90/23	0.06/1.5
P562434	LG-10	10" Level Gauge	10.00/254	11.42/290	1.38/35	.71/18	.47/12	M12 x 1.75	1.02/26	7.60/193	.90/23	
P562435	LG-10-LF	10" Level Gauge w/ Level Float	10.00/254	11.42/290	1.38/35	.71/18	.47/12	M12 x 1.75	1.02/26	7.60/193	.90/23	
P562436	LG-10-T	10" Level Gauge w/ Red Thermometer	10.00/254	11.42/290	1.38/35	.71/18	.47/12	M12 x 1.75	1.02/26	7.60/193	.90/23	
P563909	LG-10-TB-SS	10" Level Gauge w/ Blue Thermometer & Stainless Bolt kit	10.00/254	11.42/290	1.38/35	.71/18	.47/12	M12 x 1.75	1.02/26	7.60/193	.90/23	

Fast-Mount Kits

Part No.	Description
P563513	LG-3/3T
P563514	LG-5/5T, 10/10T

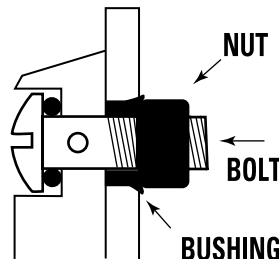

Fast Mount Assembly Instructions

Installation: Tighten nuts on bolts to the point where nuts are snug against bushings. Apply one drop of thread lock to last exposed thread at end of bolts. Mount on tank and tighten to 7 ft.-lbs./1kg-m.

(DO NOT OVER-TIGHTEN).

Removal: Loosen bolts and remove.

(IMPORTANT: THREAD LOCK PREVENTS OVER-LOOSENING OF BOLTS TO POINT WHERE NUTS DROP OFF INTO TANK.)

Easy.



Easier.



NOW YOU CAN SHOP FOR DONALDSON REPLACEMENT FILTERS ONLINE.

Visit shop.donaldson.com on your computer, phone or tablet to find all your top-quality aftermarket filters including fuel, lube, coolant and air intake filters for diesel engines, hydraulic and bulk tank filtration—plus exhaust system components. Distributors can now order directly with a secure login that provides access to all your account information—including past orders—so you can simply re-order with a click.

Shop.donaldson.com makes ordering replacement filters easier than easy so you can keep your business moving.

Shop for filters the easier way at
shop.donaldson.com



What Can Fluid Analysis Do For You?

Fluid analysis is a snapshot of what is happening inside your equipment. It summarizes the condition of your oil and identifies component wear and contamination in virtually any application.

- Identify opportunities for optimizing filtration performance
- Safely extend drain intervals
- Minimize downtime by identifying minor problems before they become major failures
- Maximize asset reliability
- Extend equipment life

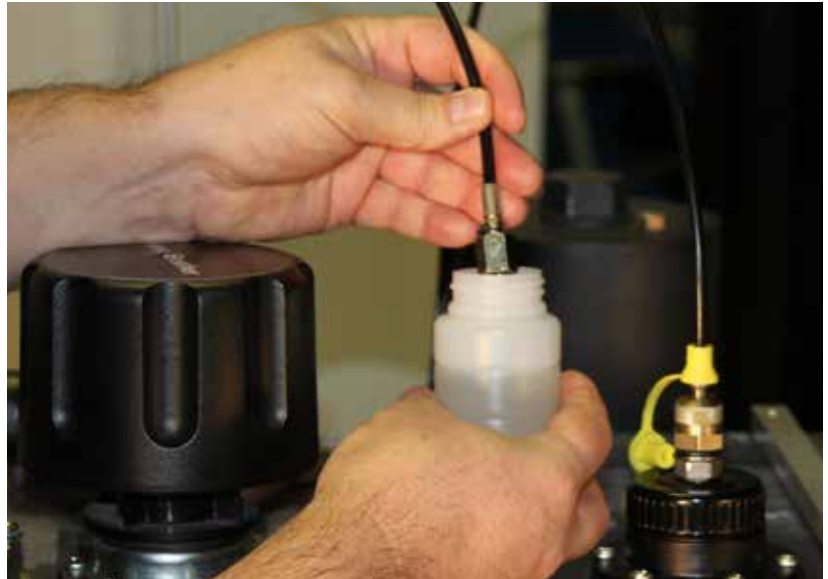

Section Index

Fluid Analysis Service	214
Analysis Program.....	214
Portable Fluid Analysis Kit.....	221

Suggested Sampling Intervals and Methods

Fluid analysis is most effective when samples are representative of typical operating conditions. Always take samples at regularly scheduled intervals and from the same sampling point each time. How critical a piece of equipment is to production should be a major consideration for determining sampling frequency.

Hydraulic	250-500 hours	By vacuum pump through oil fill port of system reservoir at mid-level
Gearboxes	750 hours	By vacuum pump through oil level plug or dipstick retaining tube
Compressors	Monthly or at least every 500 hours	By vacuum pump through oil fill port of system reservoir at mid-level
Turbines	Monthly or at least every 500 hours	By vacuum pump through oil level plug or dipstick retaining tube

Test Kits and Sampling Products Outside of North America: The fluid sampling program featured in this section is used by North American customers. If you're located outside of North America, we recommend you contact your local Donaldson distributor to discuss availability.



Fluid Analysis Program

The Donaldson Advanced Fluid Analysis Kit is designed to monitor component wear, contamination and fluid condition.

Benefits

- Partnership with a total filtration solutions provider
- High quality testing by an ISO 17025 A2LA accredited laboratory
- Results available immediately upon sample processing completion
- Innovative data management tools that will help you affect change in daily maintenance practices.

How Send Samples to the Laboratory

STEP A | Sample Information

First-time users need to establish a Horizon® account, and new components (sample point) need to be added to your account. Go to this address: www.eoilreports.com/login

Next, fill out the QR code label  with the corresponding Component ID and Sample Date. Attach the label to the sample jar and retain the other label for your records.

To improve accuracy and ensure faster processing, use the Sample Submission feature in Horizon to send the sample information to the laboratory. Once the information is submitted online, the QR code will contain all required sample information needed for processing.

NOTE: Provide the laboratory with as much detailed equipment and fluid information as possible. More in-depth analysis is possible when the analyst knows the time on both the unit and fluid and whether the fluid and/or filter have been changed since last sampled.

STEP B | Laboratory Locations

A list of available laboratory locations is included on the form. Label your package with the laboratory address of your choice and ship it using a trackable shipping service, such as UPS or FedEx.

STEP C | Online Access

If the sample information cannot be submitted online, complete the simple form on the right, detach the form and submit it to the laboratory with the sample.

IMPORTANT: Samples will be placed on hold if the component ID does not match an ID in your account and no component information is included on the paper form. Components can be added to your account online via Horizon or by contacting Customer Service. Samples placed on hold for more than 30 days will be disposed.



Fluid Sampling Products	Part No.
Fluid Analysis Kit	X009330
Sample Extraction Pump	P176431

ADVANCED INDUSTRIAL
1-877-408-3113 | www.donaldson.com
X009330 | Oil Samples Only

ONLINE SUBMISSION INSTRUCTIONS

1. Scan the QR code on the label to access the online submission form.

2. Complete the form with the following information:

- Component ID (e.g., 00000A00000)
- Sample Date
- Sample Time
- Component Type and Location
- Transmission
- Temperature
- Pressure
- Other

3. Attach the form to the sample jar and retain the other label for your records.

LABORATORY LOCATIONS

DONALDSON LABORATORY 2500 WINDYBUSH DRIVE INDIANAPOLIS, IN 46226 TEL: 317-251-1000 3300 SALT CREEK AVE. STE B P.O. BOX 10020 SALT LAKE CITY, UT 84104	DONALDSON LABORATORY 1001 75th ST HOUSTON, TX 77061 TEL: 281-281-1000	DONALDSON LABORATORY 5140 CIVIL STREET CONROCK, AL 36026 TEL: 205-654-1000
---	--	---

COMPONENT & INSTALLATION INFORMATION

Component ID: _____
 Secondary ID: _____
 Component Type and Location: _____
 Transmission: Tr Turbine
 Temperature: Tr Turbine
 Pressure: Tr Turbine
 Other: _____
 Date Taken: _____
 Fluid Type: _____
 Component Time: _____
 Filter Part #: _____
 Comments: _____

LABORATORY & INSTALLATION INFORMATION

Manufacturer: _____
 Model: _____
 Product M#: _____
 Product & Viscosity Grade: _____

Test Points, Adapters and Hose Assemblies

If you have filters installed in hard-to-access locations, test points, adapters and hose assemblies can be used to plumb up a bulkhead to read pressure differentials.

See Accessories Section for complete offering!



Test Results / Reports from Your Sample

Your Donaldson test report color codes individual results by severity for a better understanding of the overall severity of the report. It also provides a graphical representation of the cleanliness level of the fluid with a photo micropatch accompanied by the Target ISO Chart done on each sample.

With Donaldson, you're also on track for total program management with problem summary reports, sample processing turnaround tracking and data mining capabilities that allow you to affect positive change in your daily maintenance practices.

- Get test results almost immediately – online
- Identify significant trends in fluid cleanliness
- Use management reports to pinpoint problems with critical units
- Identify bottlenecks in sample turnaround time
- Influence equipment purchasing decisions
- Access your information from anywhere there is an internet connection



Information		Component Information		Sample Information	
Donaldson	Lubricant Analysis Report	Component ID: LINE 2 HYD SYSTEM T	Tracking Number: 1812M00731	Lab Number: 1794788	Lab Location: India/Reports
North America: +1-877-458-3113		Secondary ID: ON FOOD	Manufacturer: Information Requested	Model: Information Requested	Application: PLANT INDUSTRIAL
Manufacturer: KREIDER		Component Type: HYDROSTATIC TRANSMISSION	Turns Capacity: 0 gal	Sampled: 22 Nov 2018	Reviewed: 26 Nov 2018
5 CUSTER AVE		Manufacturer: Information Requested		Completed: 06 Dec 2018	
V HOLLAND, PA US		Product Manufacturer: Information Requested			
155-5419		Product Name: Information Requested			
		Viscosity Grade: Information Requested			
Filter Type: Information Requested	Filter Part#: NOT IDENTIFIED	Comments: Check for source of water contamination (DUALS, BREATHERS, FILL PORTS). Water is at a SERVICE LEVEL. Support Pump System. Lower particle count results may be invalid or unable to be tested due to water contamination. IN OPERATIONAL/STATIONARY RESULTS may be skewed due to excess water. Support spectrometric analysis may be skewed due to excessive water contamination. In order to properly compare data to the correct standards, please provide COMPONENT MANUFACTURER and MODEL, and the FLUID MANUFACTURER, PRODUCT NAME, and VISCOSITY GRADE. Please provide filter type and micron rating to allow for proper particle count evaluation.			
Micron Rating: 0					
Wear Metals (ppm)		Contaminant Metals (ppm)		Multi-Source Metals (ppm)	
Sample #	Chromium	Iron	Vanadium	Aluminum	Lead
1	0	0	0	0	0
2	0	0	0	0	0
3	0	0	0	0	0
4	0	0	0	0	0
5	0	0	0	0	0
6	0	0	0	0	0
7	0	0	0	0	0
8	0	0	0	0	0
9	0	0	0	0	0
10	0	0	0	0	0
11	0	0	0	0	0
12	0	0	0	0	0
13	0	0	0	0	0
14	0	0	0	0	0
15	0	0	0	0	0
16	0	0	0	0	0
17	0	0	0	0	0
18	0	0	0	0	0
19	0	0	0	0	0
20	0	0	0	0	0
21	0	0	0	0	0
22	0	0	0	0	0
23	0	0	0	0	0
24	0	0	0	0	0
25	0	0	0	0	0
26	0	0	0	0	0
27	0	0	0	0	0
28	0	0	0	0	0
29	0	0	0	0	0
30	0	0	0	0	0
31	0	0	0	0	0
32	0	0	0	0	0
33	0	0	0	0	0
34	0	0	0	0	0
35	0	0	0	0	0
36	0	0	0	0	0
37	0	0	0	0	0
38	0	0	0	0	0
39	0	0	0	0	0
40	0	0	0	0	0
41	0	0	0	0	0
42	0	0	0	0	0
43	0	0	0	0	0
44	0	0	0	0	0
45	0	0	0	0	0
46	0	0	0	0	0
47	0	0	0	0	0
48	0	0	0	0	0
49	0	0	0	0	0
50	0	0	0	0	0
51	0	0	0	0	0
52	0	0	0	0	0
53	0	0	0	0	0
54	0	0	0	0	0
55	0	0	0	0	0
56	0	0	0	0	0
57	0	0	0	0	0
58	0	0	0	0	0
59	0	0	0	0	0
60	0	0	0	0	0
61	0	0	0	0	0
62	0	0	0	0	0
63	0	0	0	0	0
64	0	0	0	0	0
65	0	0	0	0	0
66	0	0	0	0	0
67	0	0	0	0	0
68	0	0	0	0	0
69	0	0	0	0	0
70	0	0	0	0	0
71	0	0	0	0	0
72	0	0	0	0	0
73	0	0	0	0	0
74	0	0	0	0	0
75	0	0	0	0	0
76	0	0	0	0	0
77	0	0	0	0	0
78	0	0	0	0	0
79	0	0	0	0	0
80	0	0	0	0	0
81	0	0	0	0	0
82	0	0	0	0	0
83	0	0	0	0	0
84	0	0	0	0	0
85	0	0	0	0	0
86	0	0	0	0	0
87	0	0	0	0	0
88	0	0	0	0	0
89	0	0	0	0	0
90	0	0	0	0	0
91	0	0	0	0	0
92	0	0	0	0	0
93	0	0	0	0	0
94	0	0	0	0	0
95	0	0	0	0	0
96	0	0	0	0	0
97	0	0	0	0	0
98	0	0	0	0	0
99	0	0	0	0	0
100	0	0	0	0	0

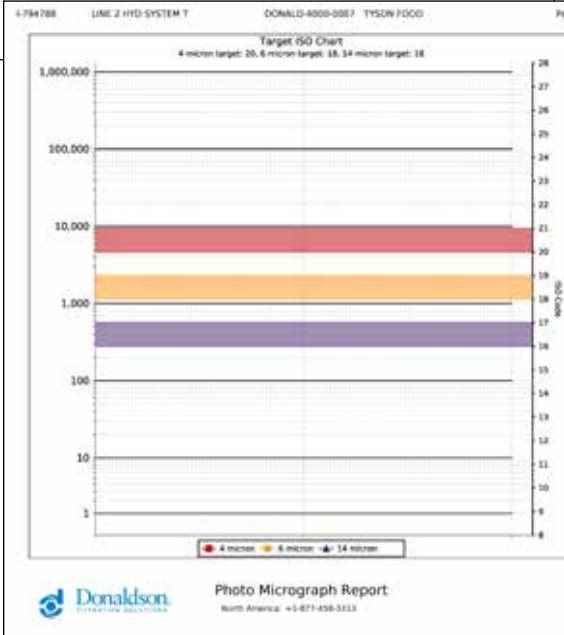



How to Read the Donaldson Fluid Analysis Report

Reading a fluid analysis report can be an overwhelming and sometimes seemingly impossible task without an understanding of the basic fundamentals for interpreting laboratory results and recommendations. Referring to the report descriptions and explanations below will help you better understand your results and, ultimately, better manage a productive, cost-saving reliability program.

Customer, Equipment and Sample Information

The information submitted with a sample is as important to who is reading the report as it is to the analyst interpreting the test results and making recommendations. Know your equipment and share this information with your laboratory. Accurate, thorough and complete lube and equipment information not only allows for in-depth analysis, but can eliminate confusion and the difficulties that can occur when interpreting results.

Lubricant Analysis Report
North America: +1-877-458-3313

Overall report severity based on comments: 0 1 2 3 4

Account Information Account Number: DONALD-4000-0007 Company Name: TYSON FOOD Contact: JEFF KRIEDER Address: 403 S CUSTER AVE NEW HOLLAND, PA US Phone Number: 717-355-5459	Component Information Component ID: LINE 2 HYD SYSTEM T Secondary ID: Component Type: HYDROSTATIC TRANSMISSION Manufacturer: Information Requested Model: Information Requested Application: PLANT/INDUSTRIAL Sump Capacity: 0 gal	Sample Information Tracking Number: 16125600733 Lab Number: 1794788 Lab Location: Indianapolis Data Analyst: RNM Sampled: 22-Nov-2018 Received: 30-Nov-2018 Completed: 06-Dec-2018
Filter Information Filter Type: Information Requested Micron Rating: 0	Miscellaneous Information Filter Part#: NOT IDENTIFIED	Product Information Product Manufacturer: Information Requested Product Name: Information Requested Viscosity Grade: Information Requested
Comments Check for source of water contamination (SEALS, BREATHERS, FILL PORTS). Water is at a SEVERE LEVEL. Suggest flushing system. Laser particle count results may be invalid or unable to be tested due to water contamination. If OXIDATION/NITRATION RESULTS may be skewed due to excess water. Suspect spectrometals analysis may be skewed due to extreme water contamination. In order to properly compare data to the correct standards, please provide COMPONENT MANUFACTURER and MODEL, and the FLUID MANUFACTURER, PRODUCT NAME, and VISCOSITY GRADE. Please provide filter type and micron rating to allow for proper particle count evaluation.		
Wear Metals (ppm) Copper, Lead, Tin, Silver, Vanadium, Silicon, Phosphorus, Iron, Titanium, Manganese, Calcium, Barium, Magnesium, Sodium, Potassium, Zinc		
Fluid Properties Viscosity @ 40°C, Viscosity @ 100°C, Total Acid Number, Total Alkali Number, Oxidation Stability, Water		
Particle Count (particles/ml) ISO Code: Based On 400/15, 400/18, 400/21, 400/24, 400/28, 400/32, 400/36, 400/40, 400/45, 400/50, 400/55, 400/60, 400/65, 400/70, 400/75, 400/80, 400/85, 400/90, 400/95, 400/100		
Additional Testing Water by Karl Fischer, Photo Micrograph		

Unit, Lube, Turnaround Time and Account information are listed on the left side of the report emphasizing the data most critical to laboratory processing and data interpretation. Details such as what kind of compressor, gearbox, engine, etc. influences flagging parameters and depth of analysis.

Second ID is each customer's opportunity to uniquely identify units being tested and their location.

Severity is represented on a sliding scale and is color-coded so that critical units are more apparent at first glance. Overall severity is based on report Comments—not individually flagged results.

- 0—Normal
- 1—At least one or more items have violated initial flagging points yet are still considered minor.
- 2—A trend is developing.
- 3—Simple maintenance and/or diagnostics are recommended.
- 4—Failure is eminent if maintenance not performed. Occasionally, a test result can violate the S4 excursion level. But, if there is no supporting data or a clear indicator of what is actually happening within the unit, maintenance action may not be recommended.

Manufacturer and Model can also identify metallurgies involved as well as the OEM's standard maintenance guidelines and possible wear patterns to expect.

Filter Types and their Micron Ratings are important in analyzing particle count—the higher the micron rating, the higher the particle count results.

Application identifies in what type of environment the equipment operates and is useful in determining exposure to possible contaminants.

Sump Capacity identifies the total volume of oil (in gallons) in which wear metals are suspended and is critical to trending wear metal concentrations.

Lube Manufacturer, Type and Grade identifies a lube's properties and its viscosity and is critical in determining if the right lube is being used.

The laboratory at which testing was completed is denoted by an **I** for Indianapolis and an **H** for Houston. The following Lab # is assigned to the sample upon entry for processing and should be the reference number used when notifying the lab with questions or concerns.

Data Analyst Initials

Make note of the difference between the Date Sampled and the Date Received by the lab. Turnaround issues may point to storing samples too long before shipping or shipping service problems.



Recommendations

A data analyst's job is to explain and, if necessary, recommend actions for rectifying significant changes in a unit's condition. Reviewing comments before looking at the actual test results will provide a roadmap to the report's most important information. Any actions that need to be taken are listed first in order of severity. Justifications for recommending those actions immediately follow.

Comments Check for source of water contamination (SEALS, BREATHERS, FILL PORTS). Water is at a SEVERE LEVEL. Suggest flushing system; Laser particle count results may be invalid or unable to be tested due to water contamination. IR (OXIDATION/NITRATION) RESULTS may be skewed due to excess water; Suspect spectrometals analysis may be skewed due to extreme water contamination; In order to properly compare data to the correct standards, please provide COMPONENT MANUFACTURER and MODEL, and the FLUID MANUFACTURER, PRODUCT NAME, and VISCOSITY GRADE. Please provide filter type and micron rating to allow for proper particle count evaluation.

Sample #	Wear Metals (ppm)										Contaminant Metals (ppm)			Multi-Source Metals (ppm)					Additive Metals (ppm)					
	Iron	Chromium	Nickel	Aluminum	Copper	Lead	Tin	Cadmium	Silver	Vanadium	Silicon	Sodium	Potassium	Titanium	Molybdenum	Antimony	Manganese	Lithium	Boron	Magnesium	Calcium	Barium	Phosphorus	Zinc
1	0	0	0	0	0	0	0	0	0	0	0	0	60	0	0	1	0	0	12	0	0	0	9	0

Sample #	Sample Information							Contaminants			Fluid Properties					
	Date Sampled	Date Received	Lube Time	Unit Time	Lube Change	Lube Added	Filter Change	Fuel Dilution	Soot	Water	Viscosity 40°C	Viscosity 100 °C	Acid Number	Base Number	Oxidation	Nitration
			h	h		gal		% Vol	% Vol	% Vol	cSt	cSt	mg KOH/g	mg KOH/g	abs/cm	abs/0.1 mm
1	22-Nov-2016	30-Nov-2016	0	0	Unk	0	Unk				44.4		0.02		192	134

"Highlighted" numbers denote test results the analyst has flagged because they exceed pre-set warning parameters and warrant closer examination or require action. Individual results are flagged by severity color to better explain the overall severity assigned to the sample.

Elemental Analysis

Elemental Analysis, or Spectroscopy, identifies the type and amount of wear particles, contamination and additives. Determining metal content can alert you to the type and severity of wear occurring in the unit. Measurements are expressed in parts per million (ppm).

Combinations of these Wear Metals can identify components within the machine that are wearing. Knowing what metals a unit is made of can greatly influence an analyst's recommendations and determine the value of elemental analysis.

Knowledge of the environmental conditions under which a unit operates can explain varying levels of Contaminant Metals. Excessive levels of dust and dirt can be abrasive and accelerate wear.

Additive and Multi-Source Metals may turn up in test results for a variety of reasons. Molybdenum, antimony and boron are additives in some oils. Magnesium, calcium and barium are often used in detergent/dispersant additives. Phosphorous is used as an extreme pressure additive in gear oils. Phosphorous, along with zinc, are used in anti-wear additives (ZDP).

Sample #	Wear Metals (ppm)										Contaminant Metals (ppm)			Multi-Source Metals (ppm)					Additive Metals (ppm)					
	Iron	Chromium	Nickel	Aluminum	Copper	Lead	Tin	Cadmium	Silver	Vanadium	Silicon	Sodium	Potassium	Titanium	Molybdenum	Antimony	Manganese	Lithium	Boron	Magnesium	Calcium	Barium	Phosphorus	Zinc
1	0	0	0	0	0	0	0	0	0	0	0	0	60	0	0	1	0	0	12	0	0	0	9	0

Iron (Fe)

Definition
Iron is a wear metal detected with Elemental Analysis for ICP (inductively-coupled plasma), which detects up to 20 elements. Measuring iron from the unit's oil can be a good indicator of wear. In addition, iron particles include iron, aluminum, copper, silicon, lead, tin, silver, nickel, cadmium and vanadium. For example, iron particles indicate oxidation, while excessive iron-nickel wear particles indicate abrasion. Iron particles may also indicate a leak in the engine or gearbox. Iron particles are also a common contaminant in hydraulic systems.

Standard Test Method Used
ASTM D6708

Reporting Measurement
ppm

Amount of Sample Needed
2 mL

Test Location
Oil

Possible Sources
- Ring/Cylinder Compressors
- Shaft, Turbine, Compressor, Packing (Seals)
- Gears, Housing Castings, Piston
- Rotary Compressors
- Hairs, Nails, Bearings, Coating
- Hydraulic / Control/Compressor
- Gears, Gears, Bearings, Pumps
- Hydraulic
- Rods, Chokes, Bores, Shafts, Pistons
- Rotational Sealers
- Pins, Screws, Washers
- Capscrews, Nuts, Valve Train Oil Pan Case

When reviewing your report online, you can click on the metal to see its definition, the ASTM test method used, how the results are reported, the amount of sample needed to perform the test, possible sources as to where the metal is coming from, and an illustration of the test equipment.



Test Data

Test results are listed according to age of the sample—oldest to most recent, top to bottom—so that trends are apparent. Significant changes are flagged and printed in the gray areas of the report.

Samples* appear in an oldest to newest **numbered sequence** so that results are easily associated with them throughout the report and depth of analysis.

Water in oil decreases lubricity, prevents additives from working and furthers oxidation. Its presence can be determined by crackle or FTIR and is reported in % of volume. Water by Karl Fischer determines the **amount** of water present. These results appear in the Special Testing section of your report.

Viscosity measures a lubricant's resistance to flow at temperature and is considered its most important physical property. Depending on lube grade, it is tested at 40 and/or 100 degrees Centigrade and reported in centistokes.

Sample Information								Contaminants			Fluid Properties					
Sample #	Date Sampled	Date Received	Lube Time	Unit Time	Lube Change	Lube Added	Filter Change	Fuel Dilution	Soot	Water	Viscosity 40°C	Viscosity 100 °C	Acid Number	Base Number	Oxidation	Nitration
			h	h		gal		% Vol	% Vol	% Vol	cSt	cSt	mg KOH/g	mg KOH/g	abs/cm	abs/0.1 mm
1	22-Nov-2016	30-Nov-2016	0	0	Unk	0	Unk				44.4		0.02		102	134

Particle Count (particles/mL)										Additional Testing		
Sample #	ISO Code	> 4 µm	> 6 µm	> 10 µm	> 14 µm	> 21 µm	> 38 µm	> 70 µm	> 100 µm	Test Method	Water by Karl Fischer - 6304C	Photo Micrograph
	Based On 4/6/14										ppm	
1	WA/WA/WA	WAT	WAT	WAT	WAT	WAT	WAT	WAT	WAT	Laser	257338	CMPLT

Comments are advisory only and are based on the assumption that the sample and data submitted are valid. Missing fluid or component information limits the evaluation. No warranty is expressed or implied.

#	Date	4 micron	6 micron	14 micron	ISO Code	Lab Number
1	22-Nov-2016	WAT	WAT	WAT	WA/WA/WA	I-794788

The **ISO Code** is an index number that represents a range of particles within a specific micron range, i.e. 4, 6, 14. Each class designates a range of measured particles per one ml of sample. The particle count is a cumulative range between 4 and 6 microns. This test is valuable in determining large particle wear in filtered systems.

Fuel and **Soot** results are all reported in % of volume. High fuel dilution decreases unit load capacity. Excessive soot is a sign of reduced combustion efficiency.

Oxidation measures the breakdown of a lubricant due to age and operating conditions. Oxidation prevents additives from working and therefore promotes increased acid content, as well as increased viscosity. **Nitration** is an indication of excessive "blow-by" from cylinder walls and/or compression rings and indicates the presence of nitric acid, which speeds up oxidation. Too much disparity between oxidation and nitration can indicate air to fuel ratio problems. As Oxidation/Nitration increases, TAN will also increase and TBN will begin to decrease.

Special Testing

Special testing is often done when additional, or more specific, information is needed. For example, an Analytical Ferrograph might be requested when a ferrous metal larger than 5 microns has been detected by Direct Read Ferrography. The AF can determine actual size of the particle, its composition—iron, copper, etc.—and the type of wear it's creating—rubbing, sliding, cutting, etc. Additional special testing could include, Water by Karl Fischer and RPVOT (Rotating Pressure Vessel Oxidation Test).

Photo Micropatch

A photo Micropatch is included with each test report and provides digital imagery of the wear debris, contamination and/or filter media particles found in each fluid sample. It is taken at a 100x magnification and includes the sample's ISO code and a 10 micrometer scale for particle size comparison.

I-794788 LINE 2 HYD SYSTEM T DONALD-4000-0007 TYSON FOOD Page 3
ISO Code: WA / WA / WA **Volume:** 10mL
Magnification: 100x

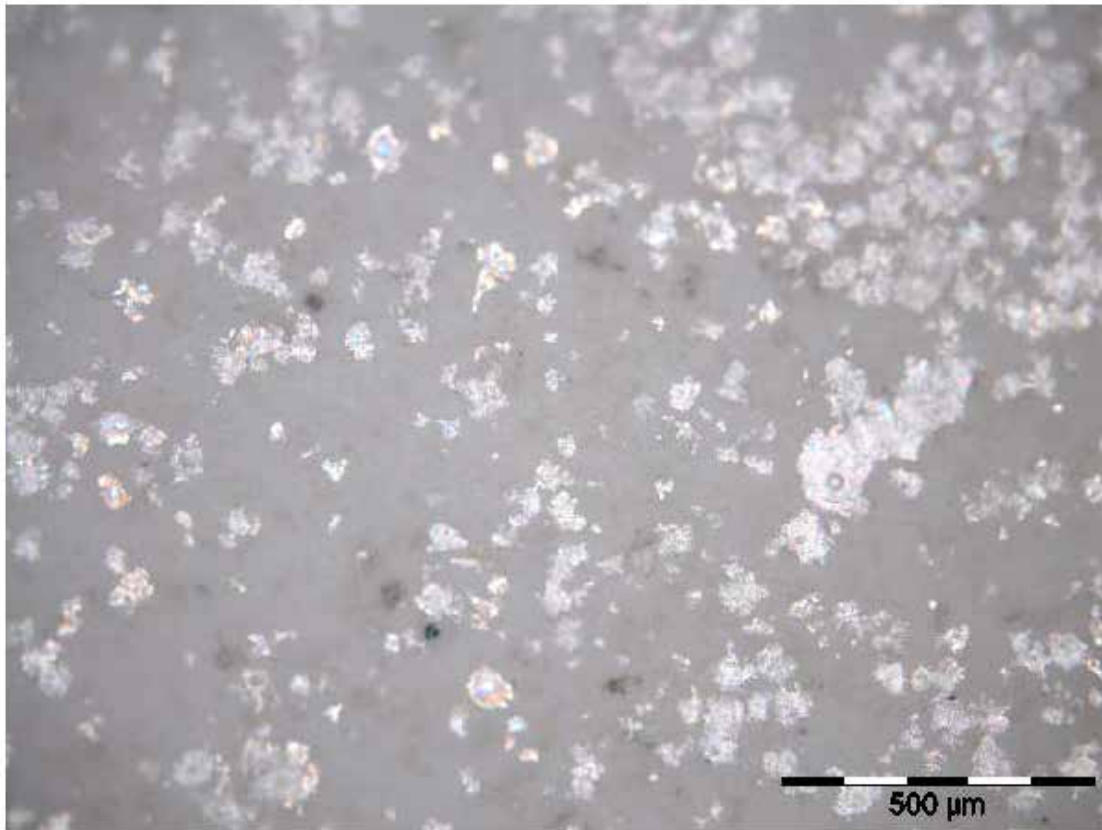

500 micrometer scale



Target ISO Chart

If target ISO codes are provided on the Component Registration Form, it will appear above the unit ID.

I-782287 64044 NL DONALD-4136-0000 WL GORE (CHERRY HILL) Page 2

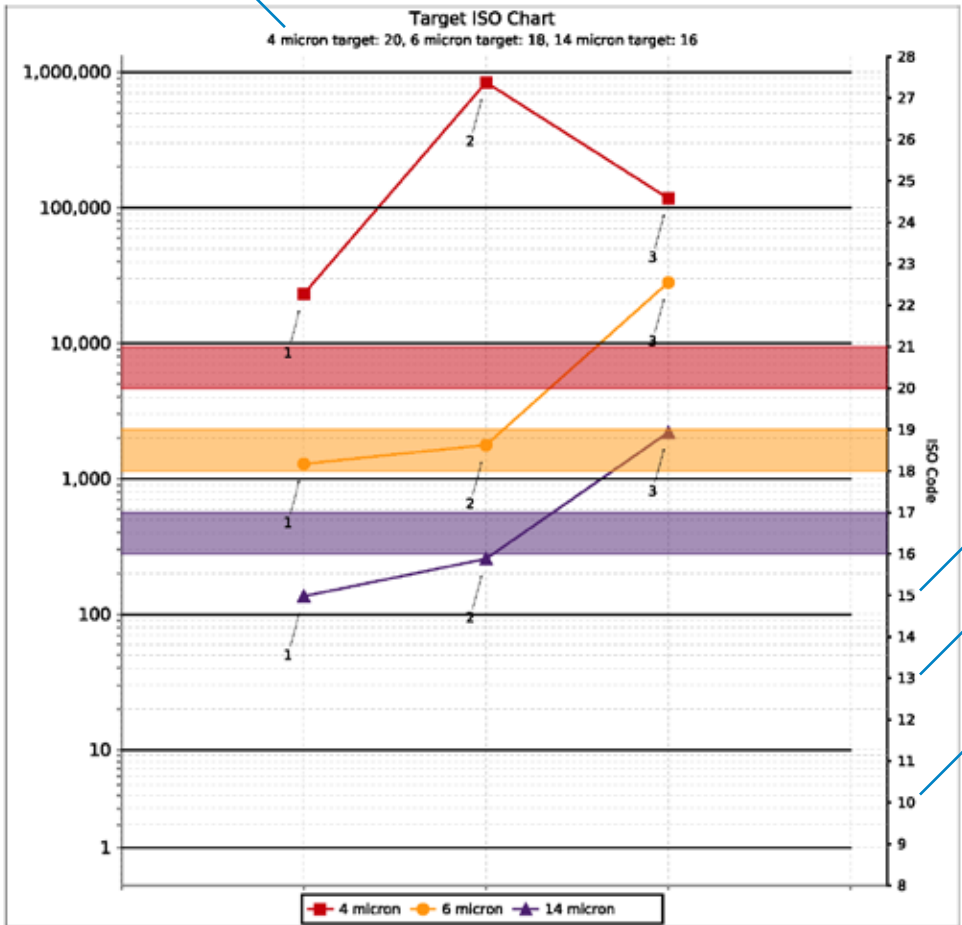

Particle count results are reported in particles per milliliter or particles per 100 milliliters at a given size (microns) and ISO Cleanliness Code. When sampling units for the first time, you must include on the Component Registration Form the target ISO Cleanliness Codes specific to each of your applications. These unit-specific codes will then pre-fill on each test report. If target ISO codes are not provided, the target ISO field will be determined by the type of hydraulics and pressure rating listed on the Component Registration Form. The 4, 6 and 14 micron particle ranges are then graphed for each sample tested.

The ISO 4406 standard utilizes a three number system to classify system cleanliness — The first number represents the number of particles present measuring greater than 4 μm. The second represents particles greater than 6 μm and the third represents those greater than 14 μm.

#	Date	4 micron	6 micron	14 micron	ISO Code	Lab Number
1	22-Nov-2016	WAT	WAT	WAT	WA/WA/WA	I-794788

Each of the ISO Code's three numbers represents an ISO range. For example, the ISO Cleanliness Code for the most recent sample in this report is 19/18/15. Because the number of 4μm particles is between 2,500 and 5,000, the corresponding ISO code is 19. Because the number of 6μm particles is between 1,300 and 2,500, the corresponding ISO code is 18. Because the number of 14 μm particles is between 160 and 320, the corresponding ISO code is 15.

Portable Fluid Analysis Kit

Fluid analysis is a snapshot of what is happening inside your equipment. It tells you the condition of the lubricant and identifies component wear and contamination in virtually any application. The Donaldson Portable Fluid Analysis Kit (**Part No. X009329**) allows you to conduct immediate on-site particulate analysis in as little as ten minutes.

Using the patch test method, you can quickly and reliably assign a three-digit cleanliness code per ISO 4406-1999 to a given fluid sample. Simply pull a 25 ml fluid sample through a patch membrane filter and compare oil sample particle distribution with the Fluid Cleanliness Comparison Guide (included) to assign an ISO Cleanliness Code.

- Use this kit to determine which systems need improved filtration.
- When improvements are made, use it to monitor the cleanliness status of the system.
- A great alternative to expensive, portable electronic devices.

Kit Contents

Kit Part Number X009329

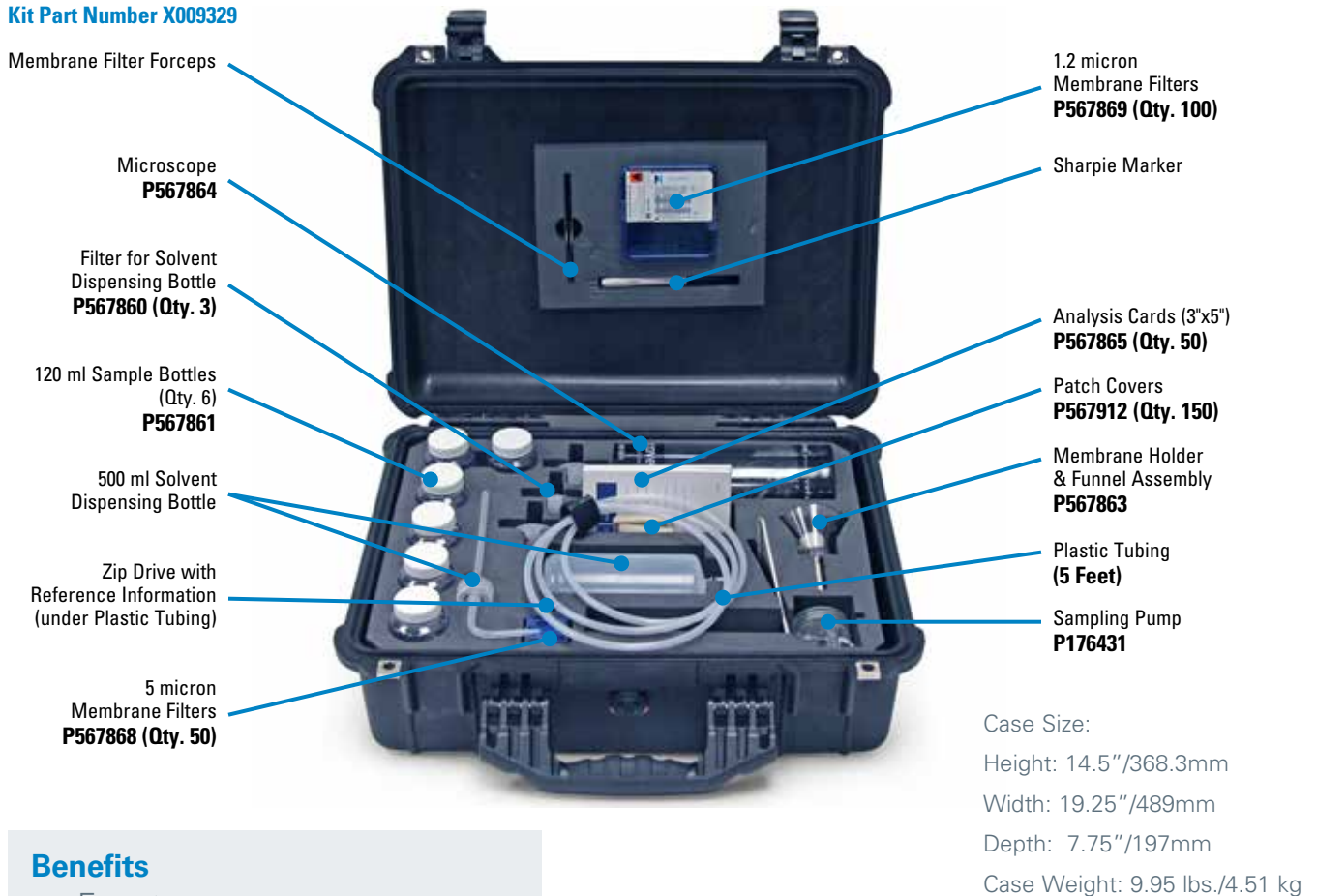

Benefits

- Easy to use
- Results in as little as 10 minutes
- Measures particulate levels
- Provides reliable results

The **Donaldson Portable Fluid Analysis Kit** includes enough supplies for 200 fluid samples. All apparatus is securely packaged and well-protected with laser-etched foam in a sturdy carrying case.



Basic Steps for Use

Kit includes detailed operating instructions and visual comparison guide.



1. Assemble waste bottle, funnel-patch assembly, and vacuum pump to form the sample processing assembly. Tighten the vacuum pump o-ring on the funnel-patch assembly tube by turning the aluminum locking device.



7. Draw the sample fluid through the patch by pulling on the vacuum pump handle.



2. Install solvent* dispensing tube and install solvent filter on end of the dispensing tube.



8. Once the entire sample has passed through the patch rinse the funnel with filtered solvent and draw through the patch. Continue to pull air through until the patch starts to dry. Then separate the funnel from the patch supporter and remove the patch with forceps.

*Mineral spirits are the most commonly used solvent



3. Rinse the funnel-patch assembly with the filtered solvent to remove background contamination. The patch should not be in place for this process.



9. Place the sample (ink/dirty side up) on a clean index card and cover it immediately with a plastic laminate patch cover.



4. Separate the funnel from the patch supporter and install a filter patch with ink grid up. (If the patch has an ink grid).



10. Analyze the sample with the 100x magnification field microscope.



5. Reattach the funnel to the filter patch base with filter patch. Twist lock the funnel to the base.



11. For best results, stand the microscope (without the lens cap or base) directly over the sample.



6. Agitate the sample fluid bottle and pour 25ml into the funnel. 25ml is denoted by the first line on the funnel (closest to the patch).

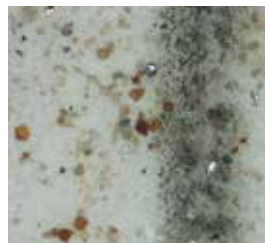

12. Use the reference photos at the back of the manual to make approximate ISO code correlation and identify contaminant types.

* Odorless mineral spirits



Off-Line Filtration: Where and Why Used

The Donaldson Filter Cart, Filter Panel, Filter Buddy™, and DCF Compact Offline Filter Unit offer convenient off-line filtration, flushing and fluid transfer.* Use them with your in-plant machinery and mobile hydraulic equipment to achieve and maintain proper ISO cleanliness levels.

*Not for use with diesel fuel or gasoline.



Section Index

Recommended Storage Practices	224
Calculating Time Required to Filter All Your Fluid Once	224
Filter Cart	225
Filter Buddy™	228
Filter Panels	230
DCF Compact Offline Filter Unit	232

New oil isn't clean oil.

To optimize system performance and lengthen component life, new oil should be filtered before being transferred into a reservoir or gearbox.

Typical Fluid Applications	Viscosity	Target ISO Cleanliness & Photo Micropatch	
Hydraulic Oil Transmission Oil Glycols (<150°F) Hydraulic Based Water Emulsions	0-500 cSt	16/14/11 	ISO 22/21/18 Typical Cleanliness of New, Delivered Fluids 
Gear Oils Glycols Phosphate Esters	0-6000 cSt	18/16/13 	



Recommended Storage Practices

Donaldson Filter Carts, Filter Buddy™, and Panels include electric motors and indoor storage is required. Exposure to rain, snow and other elements may cause electric motors to fail. Failures that result from misapplication, improper use or storage are not covered by the Donaldson warranty.

Reference document no. F110064 at www.donaldson.com/en/engine/support/datalibrary/000194.pdf

Calculating the Time Required to Filter All Your Fluid Once

When using offline filtration the fluid will need to pass through the filter cart approximately seven times to filter all your fluid once. Use the following formula to calculate the amount of time needed to filter all your fluid once:

$$\text{(Reservoir Size x 7) / Flow Rate = Time*}$$

For example: if you have a 50 gallon reservoir, it will take approximately 35* minutes to filter all your fluid once.

$$\text{(50 gallons x 7) / 10 gpm = 35 minutes}$$

*Times will vary depending on initial cleanliness of oil, system ingress, choice of media grades and other variables.

Custom Product Configurations

The following pages highlight Donaldson's stocked off-line filtration offering for quick access and convenient ordering. If an appropriate solution is not available, Donaldson is able to configure a custom solution to meet most specifications requirements. Please be prepared to provide the following information prior to contacting our qualified solutions partner. Note: product lead times will vary.

Operating Conditions

Flow Rate: _____ gpm
Temperature: °C or °F
Ambient _____ Normal Operating _____

Fluid Type:

- | | |
|--|---|
| <input type="checkbox"/> Mineral Hydraulic Oil | <input type="checkbox"/> Water-glycol |
| <input type="checkbox"/> Synthetic Hydraulic Oil | <input type="checkbox"/> HWBF |
| <input type="checkbox"/> Synthetic Gear Oil | <input type="checkbox"/> Turbine Oil |
| <input type="checkbox"/> Industrial Gear Oil | <input type="checkbox"/> Food Grade Oil |
| <input type="checkbox"/> Phosphate-ester | <input type="checkbox"/> Other |

Viscosity: (2 required)

_____ cSt or Ssu @ 40° C Temp
_____ cSt or Ssu @ 100° C Temp

Brand of Fluid: _____

Target ISO Cleanliness

In the chart to the right, circle the target cleanliness for the most stringent component in the circuit.

Betax(c) = 1000: _____ μm
Current ISO Level: _____ (18/16/13)
Capacity of Reservoir: _____ gallons/liters
Application: _____ (power unit)
Filter Media: Synthetic Cellulose Wire Mesh

Electrical

115 Volt 230 Volt

Use and Storage

Indoor Outdoor

Pumps	ISO Ratings
Fixed Gear Pump	19/17/15
Fixed Vane Pump	19/17/14
Fixed Piston Pump	18/16/14
Variable Vane Pump	18/16/14
Variable Piston Pump	17/15/13
Valves	
Directional (solenoid)	20/18/15
Pressure (modulating)	19/17/14
Flow Controls (standard)	19/17/14
Check Valves	20/18/15
Cartridge Valves	20/18/15
Load-sensing Directional Valves	18/16/14
Proportional Pressure Controls	18/16/13
Proportional Cartridge Valves	18/16/13
Servo Valves	16/14/11*
Actuators	
Cylinders	20/18/15
Vane Motors	19/17/14
Axial Piston Motors	18/16/13
Gear Motors	20/18/15
Radial Piston Motors	19/17/15

Filter Cart

The Donaldson Filter Cart provides a convenient portable mode of off-line/kidney loop filtration, flushing and fluid transfer. Use it with your in-plant machinery and hydraulic equipment to achieve and maintain proper ISO cleanliness levels.

Dual in-series HMK05 pressure filters can provide coarse/fine particle removal or, install a water absorbing filter to obtain particulate and water removal. A SP50/60 suction filter is required to protect the pump. The powerful one horsepower motor won't bog down and when coupled with a gear pump, it provides efficient fluid transfer and filtration. Convenient features include a rear mounted motor for better balance, a removable angled drip tray and clear braided hoses.

Notice

Donaldson Filter Carts include electric motors and indoor use is recommended. Exposure to rain, snow and other elements may cause electric motors to fail. Failures that result from misapplication, improper use or storage are not covered by the Donaldson warranty.

Reference the aftermarket warranty: document no. F110064.

Fluid Compatibility

Not for use with diesel fuel or gasoline. For fuel solutions, please contact the Donaldson Clean Solutions team at clean.solutions@donaldson.com or 800-374-1374.

shop.donaldson.com

Applications

- Transferring New Oil
- Cleaning Stored Oil
- System Draining
- Line Flushing
- Hose Cleaning
- Kidney Loop Filtration
- Repairs & Equipment Rebuild Flushing
- Flushing During Equipment Commissioning



Features	Benefits
Rugged and durable frame	Enables long service life
High efficiency media	Cost effective filtration
Two pressure filters	Two-stage filtration – coarse/fine or particulate/water
Safety relief valve	Prevents over pressurizing and damage to pump, hoses and filters
Overload protected switch	Prevents motor from overheating

Applications	
Filter new fluid	New fluids are usually above the recommended ISO cleanliness levels
Offline filtration	Filter cart can be used to supplement existing filtration
Water removal	Using Donaldson water removal filters to remove free water from the system.
Transferring fluid	Fluid is transferred from a storage container (tote, drum, tank, etc.) to a machine's reservoir
Flushing	After repairs & builds machines need to be flushed thoroughly before returning to service. During equipment commissioning, new machines have original fabrication debris and dirt that has ingressed during transport and storage.



Filter Cart Features

Stainless steel wands

- Will not break, corrosion resistant

Clear braided hoses

- Visually shows fluid flowing
- 85 psi working pressure

Differential pressure indicators

- Lets you know when to change filters

Suction filter

- Protects pump

Two pressure filters mounted in series

- Allows for particulate/water removal or coarse/fine particle removal

Removable angled drip tray

- Easy clean up, fluid will not leak out when tipped back



Oil sampling valve

- Monitors filter performance and cleanliness of oil

Overload protected switch

- Protects motor from overheating

Motor/Pump

- Industrial brand 10 gpm / 38 lpm flow

Integrated safety relief valve

- Protects against over pressurizing
- Set at 150 psi

Motor mounted on back

- Better balance
- Fluid will not drip on motor when changing filters

Foam filled tires

- Tires will not go flat



Filter Cart Assembly Choices

NOTE: Filters ordered separately

The Importance of Temperature When Selecting a Filter Cart

Consider operating temperature ranges when determining the proper viscosity filtration solution. It's crucial to select the proper viscosity option to maintain adequate flow and avoid restriction. Refer to the oil viscosity with temperature chart located on the front cover of the catalog.

Example: ISO Grade 32 Hydraulic Oil @ 68°F = 86.7 (cSt)

Assembly Part No.	Low Viscosity Max Viscosity 500 SUS (108 cSt)* Filters ordered separately X011297[‡]	High Viscosity Max Viscosity 8000 SUS (1700 cSt)* Filters ordered separately X011298[‡]
Operating Temperature Range:	-10° F to 160° F (-23° C to 71° C)	-10° F to 160° F (-23° C to 71° C)
Filter Bypass Valve Settings:	Suction – 5 psid/0.34 bar Pressure – 25 psid/1.7 bar	Suction – Y strainer Pressure – 25 psid/1.7 bar
Electrical Service:	115 volts: 14 amp, single phase, 60 Hz	115 volts: 14 amp, single phase, 60 Hz
Cord Length:	7 ft. /2.1m cord with storage for 50 ft./15m	7 ft. /2.1m cord with storage for 50 ft./15m
Gear Pump Flow Rate*:	10.4 gpm/38 lpm	2 gpm/8 lpm
TEFC** Motor:	1 hp, 1800 RPM	1 hp, 1200 RPM
Fluid Compatibility:	Mineral-based fluids, water glycols, polyol esters	
Dry Weight:	Approximately 140 lbs. (63.5 kg)	Approximately 175 lbs. (79.38 kg)
Dimensions:	Height: 47" (1194mm) Width: 24" (610mm) Length: 23" (585mm) Hose/Wand assembly length: 10' (3.05m)	
Filter Notes:	Requires 3 filters: 2 pressure, 1 suction	Requires 4 pressure filters

[‡]These part numbers now have relief valves in the pump. The relief valve setting is: 10.3 bar (150 PSI)

Pressure Filter Choices

Media Type	$\alpha_{x(c)} = 1000$	$\beta_{x(c)} = 2$	$\beta_{x(c)} = 1000$	Length		Part No.	Comments
	Rating based on ISO 23369	Rating based on ISO 16889		in	mm		
Synteq Synthetic			<4 μ m	14.2	361	P564468	
			6 μ m	11.6	294	P165675	
			6 μ m	11.6	294	P171274 ¹	
			6 μ m	14.2	361	P179763	
Alpha-Web	10 μ m			14.2	361	DBH0949	
Synteq Synthetic			11 μ m	7.6	193	P176207	
			11 μ m	11.6	294	P165659	
			11 μ m	11.6	294	P573996 ¹	
			11 μ m	14.2	361	P170949	
			23 μ m	7.6	193	P176208	
			23 μ m	11.6	294	P165569	
			23 μ m	11.6	294	P171276 ¹	
			23 μ m	14.2	361	P173789	
			50 μ m	11.6	294	P165672	
		50 μ m	14.2	361	P573353		
Water Absorbing		10 μ m		11.6	294	P179075	Absorbs 300 ml water

¹Fluorocarbon o-ring, epoxy

Suction Filter Choices

Media Type	$\beta_{x(c)} = 2$	Length		Part No.
	Rating based on ISO 16889	in	mm	
Wire Mesh	150 μ m	6.7	170	P550275
	150 μ m	10.7	271	P550276

*Contact Donaldson for special order options. **Totally Enclosed Fan-Cooled. Filter Notes: Refer to table in the Technical Reference Guide for fluid compatibility with our filter media. Thread sizes are 1 3/4"-12 UNF-2B (HMK05) and 1 1/2"-16 UN-2B (suction filter). Filters with seals made of fluorocarbon are required when using diester, phosphate ester fluids, water glycol, water/oil emulsions, and HWCF (high water content fluids) over 150°F. Filters with seals made of nitrile are appropriate for most applications involving petroleum oil.

Filter Buddy™

Handheld Portable Filtration System

The Donaldson Filter Buddy™ is a handheld portable system allowing you to kidney loop reservoirs that you normally cannot with larger filter carts. Its small size and light weight allows carrying up and down stairs and into tight or confined spaces. It also fits on top of a drum for convenient transferring and filtering from a drum to a reservoir.

The Filter Buddy features dual HMK04 filtration utilizing Donaldson's exclusive high efficiency Synteq™ media. The filters are plumbed in series giving you the option of coarse/fine particle removal or install a water absorbing filter for water/ particle removal.

Notice

Donaldson Filter Buddys include electric motors and indoor use is recommended. Exposure to rain, snow and other elements may cause electric motors to fail. Failures that result from misapplication, improper use or storage are not covered by the Donaldson warranty.

Reference the aftermarket warranty: document no. F110064.

Fluid Compatibility

Not for use with diesel fuel or gasoline. For fuel solutions, please contact the Donaldson Clean Solutions team at clean.solutions@donaldson.com or 800-374-1374.

Applications

- Transferring New Oil
- Cleaning Stored Oil
- System Draining
- Line Flushing
- Hose Cleaning
- Kidney Loop Filtration
- Repairs and Equipment Rebuild Flushing
- Flushing During Equipment Commissioning



Features	Benefits
Rugged and durable frame	Enables long service life
Compact size	Allows filtration in hard to reach locations
High efficiency media grades	Cost effective filtration
Dual stage filtration	Coarse/fine or water/particulate removal
Overload protected switch	Prevents motor from overheating
Sample ports	Enables system cleanliness measurements
Integrated safety relieve valve	Protects against over pressurization

Applications	
Fluid transfer	Ensure that the fluid you are transferring from a drum or tote is clean.
Offline filtration	Supplement existing filtration to achieve target ISO cleanliness levels.
Water removal	Using Donaldson water removal filters to remove free water from the system.
Filter new fluid	Clean up new fluids because they are usually highly contaminated. Don't contaminate your equipment with new fluids. Protect your equipment with proper filtration.



Filter Buddy™ Assembly Choices

NOTE: Filters ordered separately

The Importance of Temperature When Selecting a Filter Cart

Consider operating temperature ranges when determining the proper viscosity filtration solution. It's crucial to select the proper viscosity option to maintain adequate flow and avoid restriction. Refer to the oil viscosity with temperature chart located on the front cover of the catalog.

Example: ISO Grade 32 Hydraulic Oil @ 68°F = 86.7 (cSt)

Assembly Part No.	Low Viscosity Max Viscosity 900 SUS (200 cSt)* Filters ordered separately	High Viscosity Max Viscosity 8000 SUS (1700 cSt)* Filters ordered separately	
	X011303 [‡]	X011304 [‡]	X011305 [‡]
Operating Temperature Range:	-10° F to 160° F (-23° C to 71° C)		
Electrical Service:	115 volts: 8.4 amp, single phase, 60 Hz		
Gear Pump Flow Rate*:	2 gpm (7.6 lpm)	1.8 gpm (6.8 lpm)	5 gpm (18.9 lpm)
TEFC** Motor: Totally Enclosed Fan-Cooled	1/2 hp, 1725 rpm	3/4 hp, 1725 rpm	1 1/2 hp, 1725 rpm
Compatibility:	Mineral-based fluids, water glycols, polyol esters		
Hose: terminated with male NPT connections	Suction: 4' (1.2m) Length, 3/4" (1.9cm) OD	Suction: 4' (1.2m) Length, 1" (2.5cm) OD	
	Discharge: 7' (2.1m) Length, 1/2" (1.3cm) OD	Discharge: 7' (2.1m) Length, 3/4" (1.9cm) OD	
P573154 Stainless Steel Wand Kit (optional):	Suction: 40" (1.0m) Length Discharge 20" (.5m) Length		
Dry Weight:	Approximately 55 lbs. (25 kg)	Approx. 65 lbs. (29 kg)	Approx 90 lbs. (40 kg)
Dimensions:	Height: 21" (533mm) Width: 13" (330mm) Length: 26" (660mm)	Height: 25" (635mm) Width: 13" (330mm) Length: 26" (660mm)	
Filter Notes:	Requires 2 Filters		

*These part numbers now have relief valves in the pump. The relief valve setting is: 10.3 bar (150 PSI)

Filter Choices for X011303 & X011304

Media Type	$\alpha_{x(c)} = 1000$	$\beta_{x(c)} = 2$	$\beta_{x(c)} = 1000$	Length		Part No.
	Rating based on ISO 23369	Rating based on ISO 16889		in	mm	
Synteq Synthetic			<4 μm	9.4	240	P165185 ¹
			6 μm	5.97	152	P165354
			6 μm	9.4	240	P165332
Alpha-Web	10 μm			5.97	152	DBH3542
Synteq Synthetic			11 μm	5.97	152	P163542 ²
			11 μm	5.97	152	P164375
			11 μm	9.4	240	P164378
			13 μm	9.4	240	P164056 ¹
			14 μm	9.4	240	P177047
			22 μm	9.4	240	P164059 ¹
			23 μm	9.4	240	P163567 ²
			23 μm	5.97	152	P164381
			23 μm	9.4	240	P164384
			50 μm	5.97	152	P165335
			50 μm	9.4	240	P165338
Water Absorbing		10 μm		9.4	240	P560584

Filter Choices for X011305

Media Type	$\alpha_{x(c)} = 1000$	$\beta_{x(c)} = 2$	$\beta_{x(c)} = 1000$	Length		Part No.	Comments
	Rating based on ISO 23369	Rating based on ISO 16889		in	mm		
Synteq Synthetic			<4 μm	14.2	361	P564468	
			6 μm	11.6	294	P165675	
			6 μm	11.6	294	P171274 ¹	
			6 μm	14.2	361	P179763	
Alpha-Web	10 μm			14.2	361	DBH0949	
Synteq Synthetic			11 μm	7.6	193	P176207	
			11 μm	11.6	294	P165659	
			11 μm	11.6	294	P573996 ¹	
			11 μm	14.2	361	P170949	
			23 μm	7.6	193	P176208	
			23 μm	11.6	294	P165569	
			23 μm	11.6	294	P171276 ¹	
			23 μm	14.2	361	P173789	
			50 μm	11.6	294	P165672	
			50 μm	14.2	361	P573353	
Water Absorbing		10 μm		11.6	294	P179075	Absorbs 300 ml water

1. Fluorocarbon o-rings are required when using diester, phosphate ester fluids, water glycol, water/oil emulsions and HWCF (high water content fluids) over 150°F.

2. 500 psi collapse

Filter Notes:

Standard filter collapse rating is 150 psi, except as noted.

X011303 and X011304 thread sizes: 1 3/8"-12 UNF-2B (HMK04)

X011305 thread size: 1 3/4"-12 UNF-2B (HMK05).

Refer to table in the Technical Reference Guide for fluid compatibility with our filter media.



Filter Panels

Fixed-Mounted Off-Line Filtration

Donaldson Filter Panels provide fixed-mount offline/kidney loop filtration and a turnkey approach to supplemental filtration for your in-plant machinery and hydraulic equipment – helping to reduce costs and achieve and maintain proper ISO cleanliness levels.

Donaldson filter panels are offered with 4 different pump flow rates. Reservoir size, fluid viscosity and fluid temperature will help determine the correct flow rate. Filter panels feature dual HMK05 filtration utilizing Donaldson's exclusive high efficiency Synteq™ media. The filters are plumbed in series giving you the option of coarse/fine particle removal or install a water absorbing filter for water/particle removal.

Notice

Donaldson Filter Panels include electric motors and indoor installation is recommended. Exposure to rain, snow and other elements may cause electric motors to fail. Failures that result from misapplication, improper use or storage are not covered by the Donaldson warranty.

Reference the aftermarket warranty: document no. F110064.

Fluid Compatibility

Not for use with diesel fuel or gasoline. For fuel solutions, please contact the Donaldson Clean Solutions team at clean.solutions@donaldson.com or 800-374-1374.



Applications

- Transferring New Oil
- Cleaning Stored Oil

Features	Benefits
High efficiency media grades	Cost effective filtration
Dual-stage filtration	Coarse/Fine or Water/Particulate removal
Differential pressure indicators	Alerts you when to change filters
Optional overload protected switch	Prevents motor from overheating
Sample port	Enables system cleanliness measurements
Integrated safety relieve valve	Protects against over pressurization

Applications	
Offline filtration	Supplement existing filtration to achieve target ISO cleanliness levels.
Water removal	Using Donaldson water removal filters to remove free water from the system.
Filter new fluid	Clean up new fluids because they are usually highly contaminated. Don't contaminate your equipment with new fluids. Protect your equipment with proper filtration.



Filter Panel Assembly Choices

NOTE: Filters ordered separately

The Importance of Temperature When Selecting a Filter Cart

Consider operating temperature ranges when determining the proper viscosity filtration solution. It's crucial to select the proper viscosity option to maintain adequate flow and avoid restriction. Refer to the oil viscosity with temperature chart located on the front cover of the catalog.

Example: ISO Grade 32 Hydraulic Oil @ 68°F = 86.7 (cSt)

Assembly Part No.	Low Viscosity Max Viscosity 500 SUS (108 cSt)* Filters ordered separately			High Viscosity Max Viscosity 8000 SUS (1700 cSt)* Filters ordered separately
	X011299 [†]	X011300 [†]	X011301 [†]	X011302 [†]
Operating Temperature:	-10° F to 160° F (-23° C to 71° C)			
Gear Pump Flow Rate*:	3 gpm (11.4 lpm)	5 gpm (18.9 lpm)	10 gpm (37.9 lpm)	2 gpm (7.57 lpm)
TEFC** Motor:	1/2 hp, 1800 rpm	3/4 hp, 1800 rpm	1 hp, 1800 rpm	1 hp, 1200 rpm
Fluid Compatibility:	Mineral-based fluids, water glycols, polyol esters			
Connections	Inlet (pump) : SAE 12 O-Ring Outlet: SAE 20 O-Ring			Inlet (pump) : SAE 12 O-Ring Outlet: SAE 20 O-Ring
Electrical Service: 115 volts, 60 Hz single phase	8.4 amp	14 amp	14 amp	14 amp
Dry Weight:	Approx. 95 lbs. (43 kg)			Approx. 120 lbs. (54 kg)
Dimensions:	Height: 20" (508mm)		Width: 36" (915mm)	Depth: 8" (203mm)
Filter Notes:	Requires 2 Filters			Requires 4 Filters

**Totally Enclosed Fan-Cooled

[†]These part numbers now have relief valves in the pump. The relief valve setting is: 10.3 bar (150 PSI)

Filter Choices

Media Type	$\alpha_{x(c)} = 1000$	$\beta_{x(c)} = 2$	$\beta_{x(c)} = 1000$	Length		Part No.	Comments
	Rating based on ISO 23369	Rating based on ISO 16889		in	mm		
Synteq Synthetic			<4 μ m	14.2	361	P564468	
			6 μ m	11.6	294	P165675	
			6 μ m	11.6	294	P171274'	
			6 μ m	14.2	361	P179763	
Alpha-Web	10 μ m			14.2	361	DBH0949	
Synteq Synthetic			11 μ m	7.6	193	P176207	
			11 μ m	11.6	294	P165659	
			11 μ m	11.6	294	P573996'	
			11 μ m	14.2	361	P170949	
			23 μ m	7.6	193	P176208	
			23 μ m	11.6	294	P165569	
			23 μ m	11.6	294	P171276'	
			23 μ m	14.2	361	P173789	
			50 μ m	11.6	294	P165672	
			50 μ m	14.2	361	P573353	
Water Absorbing		10 μ m		11.6	294	P179075	Absorbs 300 ml water

[†]Fluorocarbon o-ring, epoxy are required when using diester, phosphate ester fluids, water glycol, water/oil emulsions and HWCF (high water content fluids) over 150°F.

Donaldson Compact Offline Filter Unit

Our DCF Compact Offline Filter Unit is the ideal solution for smaller hydraulic systems where larger offline systems aren't able to fit. The DCF is designed for permanent installation to keep your system running. Applications range from gear boxes, mobile and stationary hydraulic units and more.

Features

Proven media: Multi-layered synthetic media with water removal which is optimized for efficiency, capacity, and flow restriction.

No modification to current circuit: The compact filter unit is able to run separate from the working circuit allowing it to clean the fluid without impacting system performance.

Validation: Independent tests show that cleaning fluid in a hydraulic circuit by as little as three ISO Cleanliness Codes can increase the life expectancy of hard components by 2x.



DCF Specifications

Dimensions & Weights ¹	Height 8.5" (22 cm)	Length 27.75" (70 cm)	Width 8" (20 cm)	Weight 35 lbs (16 kg)
Connections	Inlet: 3/4" female SAE-ORB		Outlet: 1/2" female SAE-ORB	
Operating Temperature	Fluid Temperature: 30°F to 225°F (0°C to 105°C)		Ambient Temperature: -4°F to 104°F (-20C to 40C)	
Flow Rate	1.5 gpm (5.7 lpm)			
ΔP Indicator Trigger	35 psi (2.4 bar)			
Filter Assembly Bypass	50 psid (3.4 bard)			
Materials of Construction	Motor Steel	Pump Aluminum	Filter Assembly Aluminum	Element End Caps Nylon Glass Filled
Power Options	1/2 HP, 24 V DC, 20 A, Electric Motor			
Pump	Custom designed positive displacement gerotor pump with internal relief valve.			
Media Description	DTW High performance DT media combined with water removal media. Use for particulate and water removal. Rated at $\beta_{d(c)} \geq 1000$.			
Viscosity	1-2200 cSt Maximum viscosity based on dedicated DCF installations with positive inlet flooded suction. Contact factory for portable DCF maximum recommended viscosity with hoses and wands.			
Fluid Compatibility	Petroleum and mineral based fluids (standard). For polyol ester, phosphate ester, and other specified synthetic fluids use fluorocarbon seal option or contact factory.			

¹Dimensions and weights are approximations taken from base model and will vary according to options chosen.

Small size, huge results.

The vertical design allows the installation of equipment with limited space compared to filter panels or other offline filtration equipment. At only 8.5" depth, 8" wide, and 27.75" tall, the DCF can be installed on almost any piece of industrial or mobile equipment.



High viscosity performance.

The custom-designed gerotor pump was specifically designed to allow for a higher viscosity range than competing units. The DCF can pump up to a 2,200 cSt fluid, equivalent to an ISO 460 oil at room temperature. This increases the range of applications that are suitable without adding bulky heater options.

Easy filter element servicing.

Only 1.5" of clearance is required for element servicing since the bowl and filter are removed as a single piece. The element snaps into the bowl and is automatically seated to the pump as the bowl is installed. A bowl drain comes standard as well as a hex nut for easy removal and installation. The required torque is listed on the bowl for easy reference during servicing.

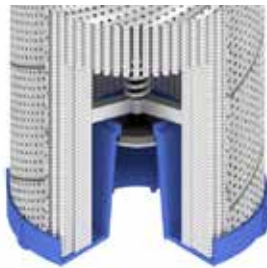

Reverse flow element with integrated bypass.

The filter elements used in the DCF utilize a reverse flow element with a bypass valve integrated into the closed end cap. The raised bypass design keeps dirt in the bottom end cap during bypass and element servicing. Every time an element is changed, a new bypass is installed eliminating bypass valve fatigue and leakage over time.

Filter panel assembly: X012223

Note: Filters ordered separately.

Filter Choices			
Element	Length	Media Code	Description
P582921	11"	DTW5	150 psid (3.4 bar) burst, 11" nominal, $\beta_{5(c)} \geq 1000$ + water absorbing, fluorocarbon seals standard
P582922	11"	DTW12	150 psid (3.4 bar) burst, 11" nominal, $\beta_{12(c)} \geq 1000$ + water absorbing, fluorocarbon seals standard

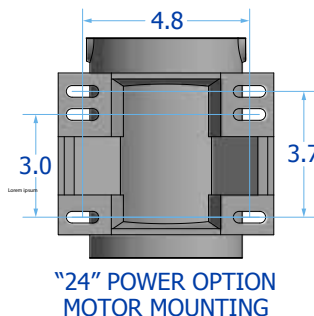
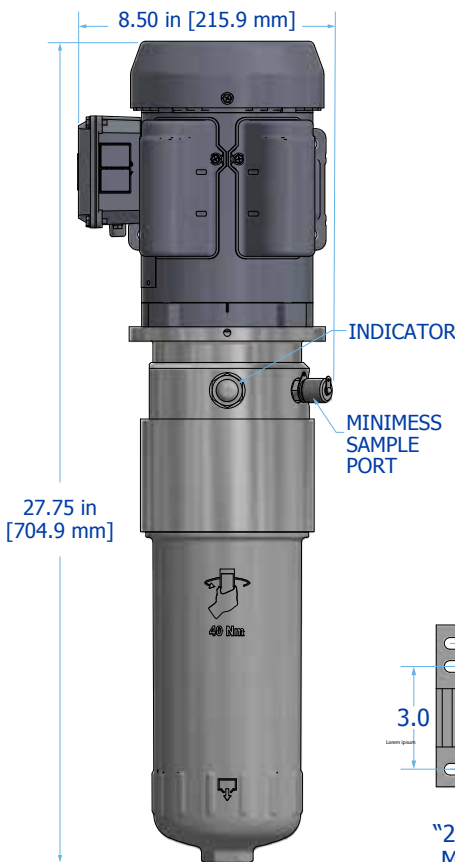

DCF Particulate/Water Removal Elements Only

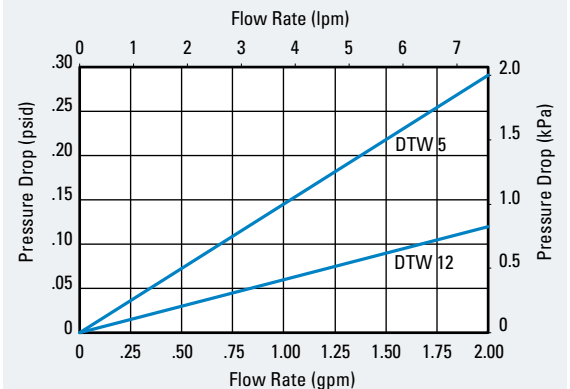

Easy.



Easier.



NOW YOU CAN SHOP FOR DONALDSON REPLACEMENT FILTERS ONLINE.

Visit shop.donaldson.com on your computer, phone or tablet to find all your top-quality aftermarket filters including fuel, lube, coolant and air intake filters for diesel engines, hydraulic and bulk tank filtration—plus exhaust system components. Distributors can now order directly with a secure login that provides access to all your account information—including past orders—so you can simply re-order with a click.

Shop.donaldson.com makes ordering replacement filters easier than easy so you can keep your business moving.

Shop for filters the easier way at
shop.donaldson.com



Bulk Fluids

The sophistication of today's equipment requires higher fuel and fluid cleanliness levels than ever before. Donaldson bulk tank filtration systems help save on costly component replacement, prevent unplanned downtime and even prevent a decrease in fuel efficiency due to injector wear. Our bulk filtration systems reduce your total cost of equipment ownership.



Section Index

Overview.....236
Part Number Listing.....238

Achieve More.





Donaldson Delivers Superior Bulk Fluid Filtration

- Lower Total Cost of Ownership
- Avoid Unplanned Downtime
- Maximize Fuel Efficiency
- Low Installation Costs
- Custom Designs
- Modular Solutions
- Compact Installation
- Low Inventory Costs
- Easily Shipped
- Easily Serviced



Clean.

Donaldson single-pass filtration on the inlet removes contamination before it can enter your storage tank and contaminate it.

Compact and easy to replace, Donaldson filters are an important line of defense in maintaining fluid quality and can be configured for high flow rates while minimizing pressure drop.



Protect.

Water absorbing filters, T.R.A.P.™ Breathers and Reservoir Air Dryers reduce the risk of moisture and contaminants entering a bulk storage tank so fluids are kept clean and dry. Used together, they'll help guard fluids from free water, airborne contamination and microbial growth for as long as they stay in storage.



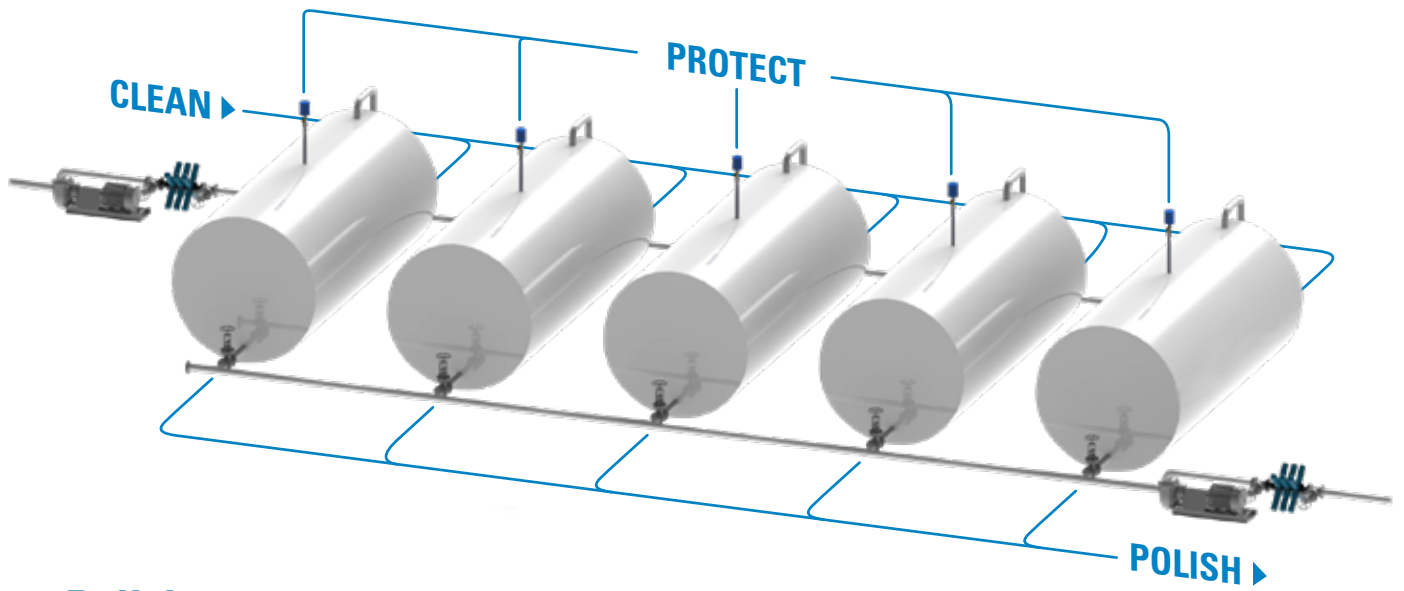

Polish.

Unstable fluids and the tank itself can be a source of contamination. Final filtration on the outlet with Donaldson filters ensures that targeted ISO cleanliness levels are achieved before fluids are pumped into your system.

Achieve More.



Filters

Max. Working Pressure: 350 psi/2413 kPa/24.1 bar
 Rated Static Burst: 800 psi/5516 kPa/55.2 bar

Part No.	Fluid Type	Max. Flow Range	Target ISO Cleanliness	Filter Efficiency
DBB5333	All diesel fuels	32 gpm/121 lpm	14/13/11	4 micron @ Beta 2000
DBB7733	All diesel fuels	32 gpm/121 lpm	16/14/11	7 micron @ Beta 2000
DBB8666	All diesel fuels	65 gpm/246 lpm	14/13/11	4 micron @ Beta 2000
DBB8777	All diesel fuels	65 gpm/246 lpm	16/14/11	7 micron @ Beta 2000
DBB8665	Transmission and hydraulic oils	65 gpm/246 lpm	16/14/11	7 micron @ Beta 2000
DBB2533	Engine and gear oils	65 gpm/246 lpm	18/16/13	25 micron @ Beta 2000
DBB8664	Engine and gear oils	65 gpm/246 lpm	18/16/13	25 micron @ Beta 2000
DBB0248	Ethanol-free fluids*	65 gpm/246 lpm	N/A	N/A

*Designed with expanding, water-absorbing media that prevents water from entering storage or equipment tanks.

Filter Heads

Max. Working Pressure: 350 psi/2413 kPa/24.1 bar
 Rated Static Burst: 800 psi/5516 kPa/55.2 bar

Part No.	Filter Qty	Mounting Connection	Max. Flow Range	Bypass
P570329	1	SAE-20 O-ring	65 gpm/246 lpm	No
P570330	1	1 1/4" NPTF	65 gpm/246 lpm	No
P568583	2	1 1/2" SAE 4-Bolt	125 gpm/473 lpm	No



Pictured with Direct Gauge Adapter: P563809
 Gauge: P562709
 Use test points and direct gauge adapters.

Filter Manifolds

Part No.	Filter Qty	Mounting Connection	Max. Flow Range
P561880	4	2" ANSI 150 Flange	250 gpm/946 lpm
P568932	8	4" ANSI 150 Flange	500 gpm/1893 lpm
P568933	10	4" ANSI 150 Flange	600 gpm/2271 lpm
DFF1012	up to 12	4" ANSI 150 Flange	700 gpm/2650 lpm



T.R.A.P.™ Breathers

T.R.A.P. breathers protect the fluids in your storage tank from airborne particulate moisture contamination and ambient moisture.

Assembly Part No.	Mounting Connection	Max. Flow Range	Filter Efficiency	Replacement Part No.
X920006	1-1/2 in NPT Female	400 gpm/1500 lpm	97% @ 3 micron	P923075



Reservoir Air Dryer

The Reservoir Air Dryer combats ambient ingress of moisture by introducing a steady flow of clean, dry air to the reservoir. No electrical requirements.

Part No.	Outlet Flow Volume @100 psi & dew point suppression	Inlet Air required @ 100 psi	Inlet/Outlet
P575852	0.5 scfm (14.2 slpm)	0.8 scfm (22.7 slpm)	1/4" NPT



DEF Filter and Housing

Max. Working Pressure: 300 psi/2068 kPa/20.7 bar

Part No.	Filter Element*	Mounting Connection	Max. Flow Range	Efficiency
P575057	P575059	1" NPT	10 gpm/38 lpm	1 micron @ Beta 5000 (99.98%)
P575058	P575059	1" BSPT		

*Filter element sold separately.



Bulk hP Filters

Designed for higher pressure delivery systems out of bulk storage tanks, typically on air pump fed hose reels in lube shops, mobile service trucks and other refer pressure single pass applications.

Element Collapse Rating: 300 psi/2068 kPa/20.7 bar
 Max. Working Pressure: 1000 psi/6895 kPa/68.9 bar
 Rated Static Burst: 2200 psi/15168 kPa/151.7 bar

Part No.	Fluid Type	Max. Flow Range	Target ISO Cleanliness	Filter Efficiency
P565184	Petroleum based oil	50 gpm/189 lpm	14/13/11	4 micron @ Beta 2000
P565185	Petroleum based oil	50 gpm/189 lpm	16/14/11	8 micron @ Beta 2000
P565183	Petroleum based oil	50 gpm/189 lpm	18/16/13	14 micron @ Beta 2000

Plastic filter cartridges and metal housings are easily separated for recycling.



Bulk hP Filter Heads

Max. Working Pressure: 1000 psi/6895 kPa/68.9 bar

Part No.	Filter Qty	Mounting Connection	Max. Flow Range	Bypass Valve
P566023	1	SAE-16 O-ring	50 gpm/189 lpm	No
P566024				50 PSI

For more information about bulk filtration systems, contact Donaldson:

Email: clean.solutions@donaldson.com

Web: mycleandiesel.com

Phone: 855-518-7784

More detailed product information can be found in the F111500 Bulk Filtration Product Guide.



Donaldson provides this technical reference as a short course in “Hydraulic Filtration 101”— for those who want to gain a better understanding of hydraulic filtration.

In stationary and mobile applications at factories all over the world, we too often see hydraulic circuits that don’t include proper fluid filtration, or include it as an afterthought. Good filtration needs to be an integral part of the hydraulic circuit to ensure the long life and proper operation of the pumps, valves and motors. A \$100 filter protects your \$100,000 equipment.

This section is offered to aid in choosing the filter that will help you achieve the ideal cleanliness levels and longest life for your critical components.

Topics

Why Hydraulic Components Need Protection.....	240
How Contamination Damages Precision Parts.....	240
Types of Contaminant	240
Typical Factors in Component Life	240
Where Contamination Comes From.....	241
Fluid Conditioning	242
Proper Filter Application	243
Fluid Properties	243
Types of Hydraulic Fluid	244
How Filter Media Functions	245
Basic Types of Filter Media	246
ISO 23369 Test Standards.....	249
ISO 16889 Test Standards.....	250
Hydraulic Filtration Pressure Drop.....	251
Fluid Viscosity/Temperature Chart.....	252
Filter Design & Construction	253
ISO Ratings and Filter Performance Ratings	254
Micron Size Comparison.....	254
ISO Beta Rating System.....	255
Application Guide for Donaldson Synthetic Media	256
Understanding the Alpha Rating System.....	257
Filter Efficiency Standards	258
Donaldson Hydraulic Filter Media Beta Rating	260
Cleanliness Level Correlation Table.....	261
Fluid to Filter Media Compatibility.....	262
A Note on Seals.....	263
Filter Positioning.....	264
Do Not Use Dented or Damaged Filters.....	266
Storage and Handling of Filters On-Site	266
Typical Hydraulic Circuit and Filter Locations	267
Maintenance Practices for Contamination Control.....	268
Spin-On Filter Servicing	268
Cartridge Filter Servicing	269
In-tank Filter Servicing	270
Application Design Worksheet	271

Symbols Used

α	Alpha Ratio
β	Beta Ratio
cSt	Centistokes
ΔP	Pressure Drop or Differential Pressure
ISO	International Standards Organization
μm	Micron or micrometer
ppm	Parts per million
SSU SUS	Saybolt Seconds Universal

Material in this section is in the public domain, not confidential, and may be copied for educational purposes at any time. Information was collected from many sources, both public and private, including Donaldson Company, Inc. Engineering Departments, Eaton Corporation, the Lightning® Reference Handbook from Berendsen Fluid Power, Hydraulics & Pneumatics Magazine, National Fluid Power Association (NFPA), and various industry authorities.



Why Hydraulic Components Need Protection

Fluid power circuits are designed in all shapes and sizes, both simple and complex in design, and they all need protection from damaging contamination. Abrasive particles enter the system and, if unfiltered, damage sensitive components like pumps, valves and motors. It is the job of the hydraulic filter to remove these particles from the oil flow to help prevent premature component wear and system failure. As the sophistication of hydraulic systems increases, the need for reliable filtration protection becomes ever more critical.

How Contamination Damages Precision Parts

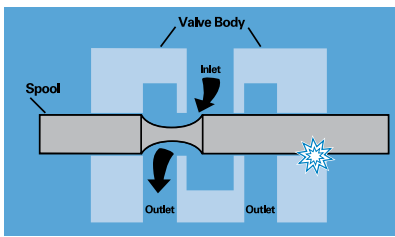

This illustration of a simple hydraulic valve illustrates how particles damage components. In normal operation, the spool slides

back and forth in the valve body, diverting oil to one side of the valve or the other. If a particle lodges between the spool and valve body, it will erode small wear particles from the metal surfaces. As these wear particles are moved back and forth by the action of the spool, they can roll into a burr that jams the spool and disables the valve.

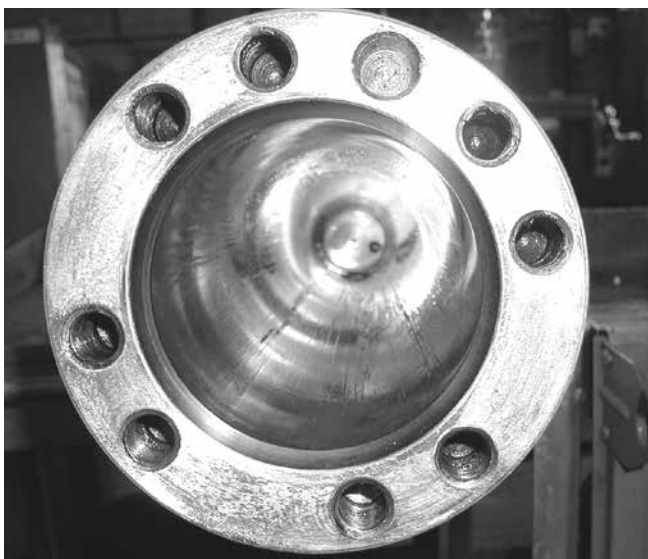

Component Damage

Looking down the barrel of an hydraulic cylinder, we can see the scratches along the inside surface. Don't cut costs by eliminating hydraulic filters. It could cost you more in the long run in major component repairs.

Types of Contaminant

Many different types of contamination may be present in hydraulic fluid, causing various problems. Some are:

- Particulate (dust, dirt, sand, rust, fibers, elastomers, paint chips)
- Wear metals, silicon, and excessive additives (aluminum, chromium, copper, iron, lead, tin, silicon, sodium, zinc, barium, phosphorous)
- Water
- Sealants (Teflon[®]* tape, pastes)
- Sludge, oxidation, and other corrosive products
- Acids and other chemicals
- Biological, microbes (in high water based fluids)

Typical Factors in Component Life

Studies show that most (typically 70%) of hydraulic component replacement is necessary because of surface degradation, and most of that is due to mechanical wear. Proper filtration of hydraulic fluids can lengthen component life.

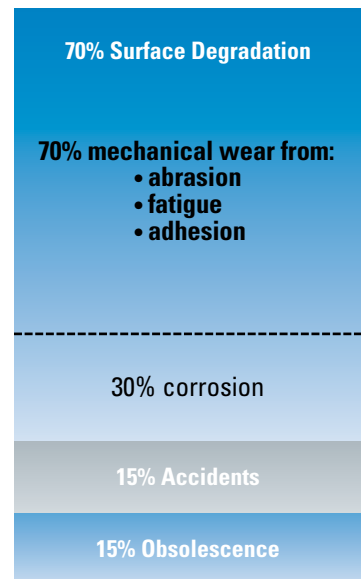

Disaster Strikes

When filters are not a main component of the hydraulic circuit, disaster awaits. Here, piston rings were eaten away by contaminants.

* Teflon is a registered trademark of E.I. Dupont de Nemours & Co., Inc.



Where Contamination Comes From

There are many sources of contamination in a hydraulic system or circuit.

New Hydraulic Fluid Adding new fluid can create contamination. New hydraulic fluid isn't clean. (What looks clean may not be - the human eye can only see a particle of about 40µm.) Oil from shipping containers is usually contaminated above acceptable levels for most hydraulic systems. Typical cleanliness levels are:

- New fluid: about the same as ISO Code 23/21/19
- Water content: 200 to 300 ppm.

Never assume your oil is clean until it is filtered. Having a dedicated off-line circulation loop, or "kidney" loop is an effective way of ensuring thorough fluid conditioning.

How Clean is Your New Oil?

Amount of contaminant in 100 gallons hydraulic oil

Donaldson Hydraulic Filter Synteq™ Media	Standard Hydraulic Filter Cellulose Filter Media	New, Unfiltered Hydraulic Oil
ISO 14/9/3 0.004 gram dust	ISO 19/17/14 0.363 gram dust	ISO 22/21/18 4.73 grams dust

New, unfiltered hydraulic oil can contain 1,000 times more contaminant than filtered oil. Contamination levels of different ISO 4406 codes vary dramatically.*

Amount of contaminant that passes through a 25 gallon hydraulic reservoir with a 25 gpm pump running for a period of 500 hours.

Synteq™ Media ISO 14/9/3	Cellulose Media ISO 19/17/14	New Hydraulic Oil ISO 22/21/18
0.03 lbs (12.5 g)	2.5 lbs (1,125 g)	32.5 lbs (4,750 g)

Hydraulic Pump Exposure to Dirt

* Derived from the ISO 16889 test standard with NIST certified on-line automatic particle counters and ISO medium test dust (assumes spherical particle shape and lower bound diameter for test dust). Achieved with $\beta_{400\mu m} > 1000$ Synteq™ media. Actual results may vary.

Built-In Built-in contamination (primary contamination), is caused during the manufacture, assembly and testing of hydraulic components. Metal filings, small burrs, pieces of Teflon tape, sand and other contaminants are routinely found in initial clean up filtration of newly manufactured systems.

Ingressed Ingressed (external) contamination comes from the environment outside the system. Dirt can enter the hydraulic fluid supply through leaking seals, reservoir breather caps, and worn cylinder rod seals. Ingressed moisture can particularly cause long-term problems. As a hot system cools at night, cool, moisture-laden air can be drawn into the reservoir. As air condenses, water is released into the reservoir. Water exceeding 0.5% by volume in a hydrocarbon-based fluid accelerates the formation of acids, sludge

shop.donaldson.com

and oxidation that can attack internal components, cause rust, and adversely affect lubrication properties. The severity and type of contaminant depend on the applications and environment.

Induced Maintenance procedures can introduce contamination into the system. Opening the system can introduce airborne particles. Leaving the system open during operation allows continuous ambient particle ingress. Keep your system closed as much as possible.

In-Operation The major sources of contamination are the pump and actuators, the hydraulic cylinder, or the hydraulic motor. Wear-generated contaminants are a hazard during normal hydraulic system operation. The circuit actually generates additional particles as the fluid comes into contact with the precision machined surfaces of valves, motors and pumps. Contaminant levels can keep doubling with every new particle generated. The result can be catastrophic if these contaminants are not properly filtered out of the system.

Rubber & Elastomers Hoses, accumulator bladders, seals, or other elastomer products can all be sources of contamination. Rubber compounds and elastomers degrade due to temperature, time, and high-velocity fluid streams, releasing particulates.

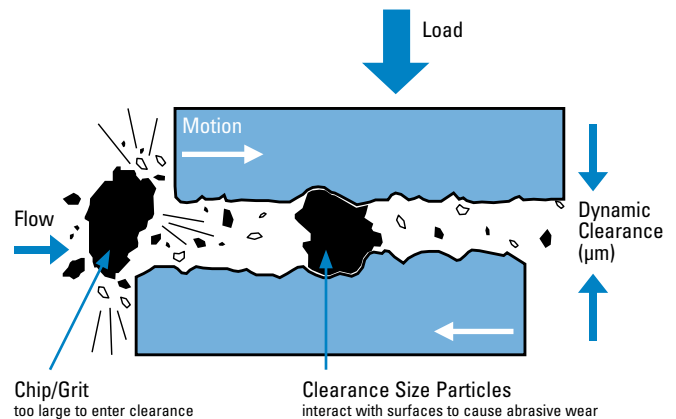

High Water Based Fluids The water in HWBF tends to support biological growth and generate organic contamination and microbes.

Replacement of Failed Components

Failure to thoroughly clean fluid conductor lines after replacing a failed hydraulic pump will cause premature catastrophic failure. Donaldson recommends frequent oil sampling to ensure proper contamination control. Sample test points should be close to hydraulic pumps and at other key locations that provide safe, reliable access to the fluid while under full system pressure.



Fluid Conditioning

Fluid Conditioning is the term for the overall conditioning of the fluid in the hydraulic system, and encompasses particulate removal via filters along with other various methods for removing silt, air, water, heat, acid, sludge or chemicals.

Particulate Removal

Particulate removal is usually done with mechanical filters. A well designed reservoir that allows settling will also help in keeping particulates out of the mainstream fluid. For ferrous particulates and rust, reservoir magnets or strainer band magnets can also be used. Other methods such as centrifuging or electrostatic filtration units can also be used, particularly in continuous batch processing and fluid reclamation.

Removal of Silt

Silt, defined as very fine particulate under 5 µm in size, requires very fine filtration or “oil polishing.”

Air Removal

Getting air out of the system is best done by adding 100 mesh screen in the reservoir, approximately 30° from horizontal to coalesce entrained air and allow larger bubbles to rise to the surface when reservoir velocities are low.

Water Removal

A number of techniques exist to prevent water or moisture ingress or to remove water once it is present in a hydraulic or lube oil system. The best choice of technique for removal is dependent on whether or not the water exists as a separate phase (dissolved or free), and also on the quantity of water present. For example, the presence of water or moisture can be reduced or prevented from entering a fluid reservoir through the use of adsorptive breathers or active venting systems. However once free water is present in small quantities, water absorbing filters

or active venting systems usually provide adequate removal means. For large quantities of water, vacuum dehydration, coalescence, and centrifuges are appropriate techniques for its removal. However, as each of these techniques operates on different principles, they have various levels of water removal effectiveness. The chart below provides comparative information on these techniques and their relative effectiveness. Care should be taken to apply the best technique to a given situation and its demands for water removal.

Chemical Removal

Removal of acids, sludge, gums, varnishes, soaps, oxidation products and other chemicals generally requires an adsorbent (active) filter with Fuller’s Earth, active type clays, charcoal, or activated alumina.

Heat Removal

Removing heat is important to maintain viscosity and prevent fluid breakdown. Usually performed with heat exchangers, including air-to-oil and water-to-oil types, finned coolers, or refrigerated units.

Heat Addition

Added heat is used for cold temp start-up to get fluid viscosities within operational limits. Use heaters, immersion or in-line.

Kidney Loop Filtration

One very effective way of ensuring thorough fluid conditioning is with a dedicated off-line circulation loop, or “kidney” loop. This system uses a separate circulation pump that runs continuously, circulating and conditioning the fluid. Multiple stages and types of filters can be included in the circuit, as well as heat exchangers and in-line immersion heaters.

Water Prevention and Removal Techniques

	Usage	Prevents Humidity Ingression	Removes Dissolved Water	Removes Free Water	Removes Large Quantities of Free Water	Limit of Water Removal
Adsorptive Passive Breather	prevention	Y				n/a
Active Venting System	prevention & removal	Y	Y	Y		down to <10% saturation
Water Absorbing Cartridge Filter	removal			Y		only to 100% saturation
Centrifuge	removal			Y	Y	only to 100% saturation
Coalescer	removal			Y	Y	only to 100% saturation
Vacuum Dehydrator	removal		Y	Y	Y	down to ~20% saturation



Proper Filter Application

When selecting a new filter assembly or replacement filter, it's important to first answer some basic questions about your application. Where will the filter be used? What is the required cleanliness level (ISO code) of your system? What type of oil are you filtering? Are there specific problems to be addressed?

It's also important to think about the viscosity of the fluid in your system. In some machinery lubrication applications, for example, the oil is very thick and has a tougher time passing through the layer of media fibers. Heating techniques and the addition of polymers can make the liquid less viscous and therefore easier to filter. Another option is to install a filter with larger media surface area, such as the Donaldson W041 or HRK10 low pressure filters, that can accommodate more viscous fluids.

Next, think about duty cycle and flow issues. Working components such as cylinders often create wide variations in flow—also called pulsating flow—that can be problematic for filters with higher efficiency ratings. On the other hand, dedicated off-line filtration (also called “kidney loop”) produces a very consistent flow, so it makes sense to use a more efficient filter.

Filters used in applications with steady, continuous operation at lower pressures will last longer than filters that must endure cycles of high pressure pulsating flow. Generally, the lower the micron rating of a filter, the more often it needs to be changed since it is trapping more particles.

Finally, it's wise to ask yourself, “How much is my equipment worth?” Calculate how much it would cost to replace the equipment in your system, in case of component failure, and make sure those areas are well protected with proper filtration. (For example, high performance servo valves are very sensitive, costly components that need to be protected with finer filtration media.)

Minimizing maintenance costs through good contamination control practices requires proper filter application based on the specific contamination problems. Good contamination control means cost-effective filtration. When looking for a filter, first assess the needs of your system and any problem areas.

Characteristics to Consider When Specifying a Filtration System

- 1) Oil Viscosity
- 2) Flow
- 3) Pressure
- 4) What Components will be protected by the filter
- 5) Cleanliness level required (expressed in ISO code)
- 6) Type of oil/fluid
- 7) Environment (the system, the surrounding conditions, etc.)
- 8) Duty cycle
- 9) Operating Temperature

Fluid Properties

Lubricity The property of the fluid that keeps friction low and maintains an adequate film between moving parts.

Viscosity The thickness of the fluid as measured by resistance to flow. The fluid must be thin enough to flow freely, heavy enough to prevent wear and leakage. Hydraulic fluids thicken when they cool and thin out as they heat up. Because some hydraulic systems work under wide temperature extremes, viscosity can be an important factor.

Viscosity Index (VI) The rate of viscosity change with temperature: the higher the index, the more stable the viscosity as temperature varies. VI can sometimes be improved by additives, usually polymers.

Rust Resistance Rust inhibiting chemicals in hydraulic fluids help overcome the effects of moisture from condensation.

Oxidation Resistance Oxidation inhibitors delay the sludgy/acidic effects of air, heat, and contamination in the system.

Foaming Resistance Although control of foaming depends largely on reservoir design, anti-foaming additives in the fluid also help.



Types of Hydraulic Fluid

There are many kinds of fluids used for power, but they can basically be called petroleum-based fluids, biodegradable fluids, and fire-resistant fluids. A brief description of some of the types in each category are listed below; for details on these or others, consult your filter supplier or refer to a reputable manual on hydraulics, such as the Lightning Reference Handbook, published by Berendsen Fluid Power, Whittier, CA 90601.

Petroleum Based (Hydrocarbon)

These are the most commonly used fluids in hydraulic systems. Their major advantages are low cost, good lubricity, relatively low/non-toxicity, and common availability. This type of fluid is not just plain oil; rather, it is a special formulation with additives that make it suitable for hydraulic systems. Mostly, the additives inhibit or prevent rust, oxidation, foam and wear.

Variations:

- Straight oils: same as petroleum-based oil but without the additives.
- Automatic transmission fluids (ATF): excellent low temp viscosity and very high VI.
- Military hydraulic fluids (ie: MIL-H-5606 and MIL-H-83282): also called 'red oil' because of the color. Low viscosity, good for cold temp operations, but may have to be modified for pumps.

Fire Resistant Fluids

There are two types of fire-resistant fluids commonly used in hydraulic applications: Phosphate Esters and High Water Content Fluids (HWCF). Although generally not as viscous at cold temperatures as petroleum-based fluids, they are fire resistant due to their high content of noncombustible material. Very useful in overcoming the likelihood of fire caused by a broken hydraulic line spraying petroleum fluid into a pit of molten metal, onto a hot manifold, into a heat-treating furnace, or other ignition source.

Some types of HWCF:

- Oil-in-water emulsions (HFA): typically 95% water and 5% oil, with the oil droplets dispersed throughout the water. Provide some fire resistance, but due to oil content, other fluids are superior.
- Water-in-oil emulsions (invert emulsion HFB): typically 40% water and 60% oil, with the water dispersed in the oil. Provide some fire resistance, but due to oil content, other fluids are superior.

- Water-glycol (HFC): typically 40% water and 60% glycol. Excellent fire resistance. Since glycol is an antifreeze, water-glycol can be used at lower temps.

NOTE: HWCF may require reduced pressure rating of pumps and other components.

HFD Fluids

The HFD group is a classification given to several different types of synthetic products that do not contain petroleum oil or water. Phosphate ester fluids were the first HFD fluids and are the most fire resistant within the HFD family. Not as popular today, their use declined due to poor environmental performance, limited compatibility, and high cost. Certain phosphate esters have very high auto-ignition temperatures and are still used in specific applications, such as aircraft and power generation. A common brand is known as Skydrol® (registered trademark of Solutia Inc., a subsidiary of Eastman Chemical Company). Skydrol requires EPR seal for chemical compatibility. Today most phosphate esters have been replaced by polyol esters. Based on organic esters, polyol esters are the most common HFD fluids used today. They offer good inherent fire resistance, good compatibility with system materials, excellent hydraulic fluid performance, and easy conversion from petroleum oil. In addition, the organic nature of these fluids gives them good environmental performance in biodegradability and aquatic toxicity. Another type of synthetic, fire resistant fluids have been formulated for certain niche markets. Water free polyalkylene glycols (PAGs) feature extended fluid life and good environmental performance. Technically an HFD fluid, PAGs (also known as polyalphaolefins (PAOs) are more often used for their biodegradability and overall environmental friendliness. This group also contains the synthetic silicone (siloxane) oils, known for their anti-foaming properties.

Biodegradable

With increasing concern about the environmental impact of hydraulic system leaks and spills, biodegradable fluids are receiving expanded usage, particularly in Europe. There are two types of common biodegradable hydraulic fluids: 1) vegetable-based oils, such as sunflower or rapeseed (canola) oils, and 2) synthetic oils like diesters, etc. Generally, systems using biodegradable fluids are derated for maximum and minimum temperatures. Users who replace standard hydraulic oils with biodegradable oils must check with filtration component manufacturers to confirm that the fluid and components are compatible.



How Filter Media Functions In a Filtration System

The job of the media is to capture particles and allow the fluid to flow through. For fluid to pass through, the media must have holes or channels to direct the fluid flow and allow it to pass. That's why filter media is a porous mat of fibers that alters the fluid flow stream by causing fluid to twist, turn and accelerate during passage.

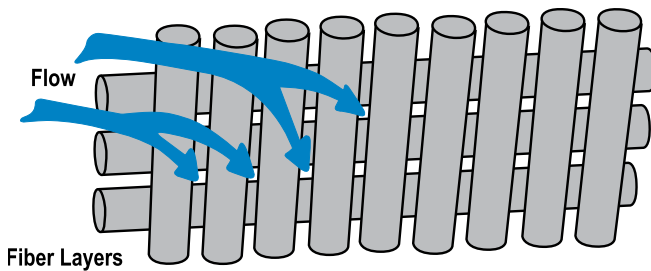

The fluid changes direction as it comes into contact with the media fibers, as illustrated above. As the fluid flows through the media, it changes direction continuously as it works its way through the maze of media fibers. As it works its way through the depths of the layers of fibers, the fluid becomes cleaner and cleaner. Generally, the thicker the media, the greater the dirt-holding capacity it has.

Looking at a cross-section view of the fibers, we can see how the flowstream is accelerated as it flows into the spaces between the fibers.

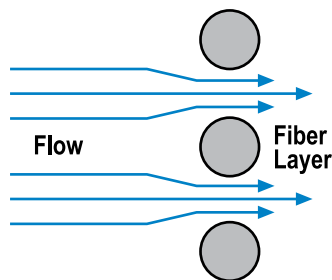

How Filter Media Collects Particles

There are four basic ways media captures particles.

The first, called **inertia**, works on large, heavy particles suspended in the flow stream. These particles are heavier than the fluid surrounding them. As the fluid changes direction to enter the fiber space, the particle continues in a straight line and collides with the media fibers where it is trapped and held.

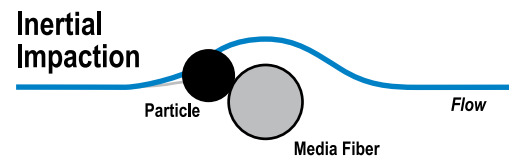

The second way media can capture particles is by **diffusion**. Diffusion works on the smallest particles. Small particles are not held in place by the viscous fluid and diffuse within the flow stream. As the particles traverse the flow stream, they collide with the fiber and are collected.

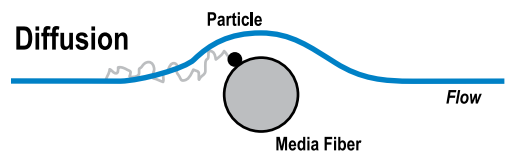

The third method of particle entrapment is called **interception**. Direct interception works on particles in the mid-range size that are not quite large enough to have inertia and not small enough to diffuse within the flow stream. These mid-sized particles follow the flow stream as it bends through the fiber spaces. Particles are intercepted or captured when they touch a fiber.

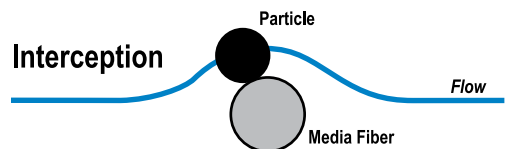

The fourth method of capture is called **sieving** and is the most common mechanism in hydraulic filtration. As shown at right, this is when the particle is too large to fit between the fiber spaces.

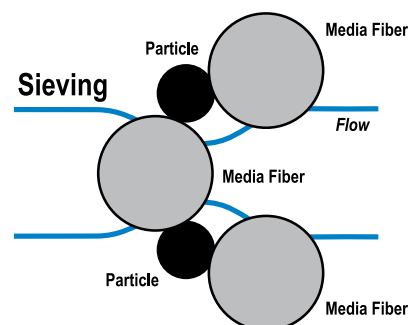



Basic Types of Hydraulic Filter Media Filter Media

Media is a term used to describe any material used to filter particles out of a fluid flow stream. There are seven basic types used to remove contamination in hydraulic applications:

DT High-Performance Media (Synthetic)

Donaldson high-performance DT grades of Synteq media utilize a blend of synthetic fibers optimizing efficiency and initial pressure drop. Donaldson filter media scientists found this provides the best available chemical resistance for the broadest array of hydraulic applications.

DT High-Performance media is ideal for use with phosphate ester and water glycol fluids.

HOW IT WORKS

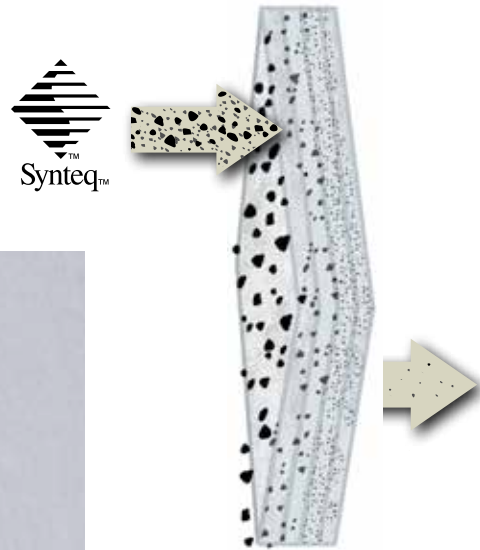

SEM 100X

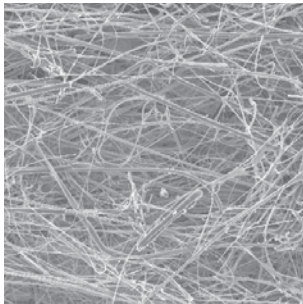

SEM 600X

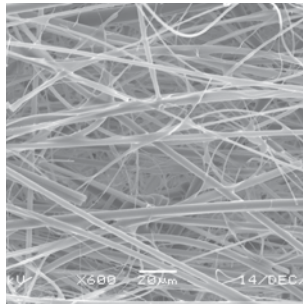

MEDIA IMAGE

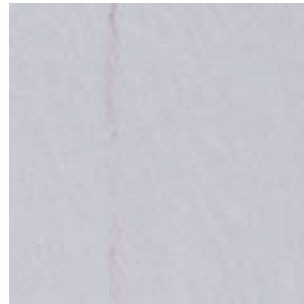

The chemical and thermal compatibility of fluid filters is an increasingly difficult design challenge due to the complex variety of fluid systems. Today's fluid systems are often tailored towards the special needs fire resistance, biodegradability, and electrical insulating ability. Fortunately, there are media solutions available to meet these challenges.

Donaldson DT Synteq Media Efficiency

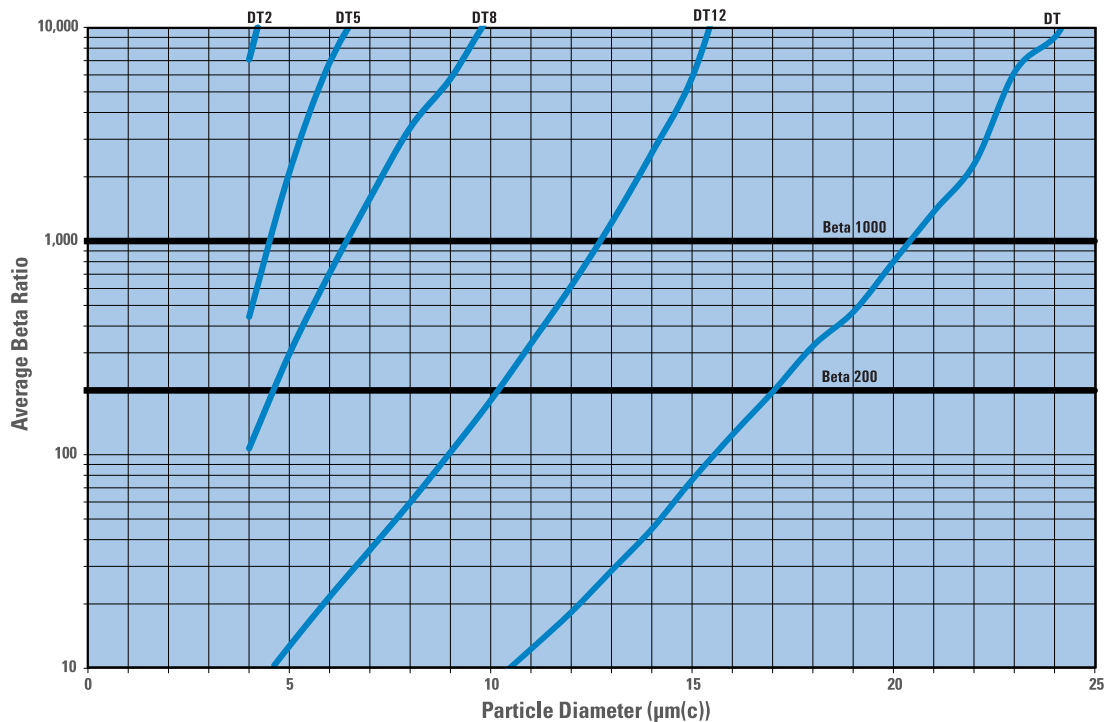

Alpha-Web™ Media (Synthetic)

Donaldson Alpha-Web media was developed by Donaldson scientists for real world hydraulic applications. In real world hydraulic applications, contaminant particles can become dislodged from filter media with varying flowrates. Donaldson's Alpha-Web media utilizes a fine fiber layer that traps and locks particles that outperforms conventional media in cyclic flow efficiency testing.

SEM 100X

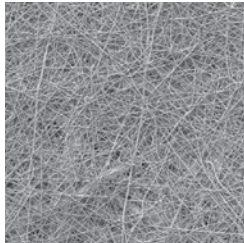

SEM 600X

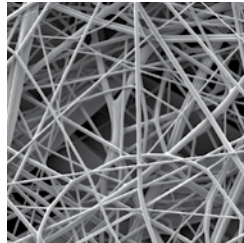

MEDIA IMAGE



ALPHA-WEB™

HOW IT WORKS

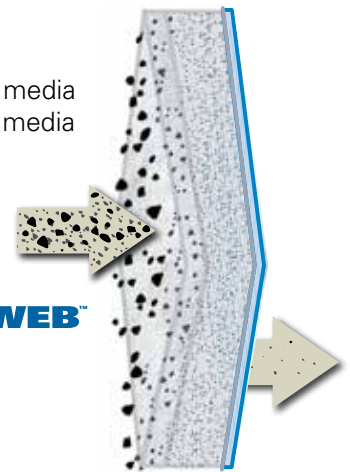

Synteq™ Media (Synthetic)

Synthetic fibers are man-made, smooth, rounded and consistent in shape, allowing control of the fiber size and distribution pattern throughout the media mat. This gives the smoothest, least inhibited fluid flow. Consistency of fiber shape allows maximum contaminant-catching surface area and specific pore size control. The result is media with predictable filtration efficiencies removing specified contaminants and maximum dirt holding capacity.

The low resistance of synthetic media to fluid flow makes it ideal for use with synthetic fluids, water glycols, water/oil emulsions, HWCF and petroleum-based fluids.

SEM 100X

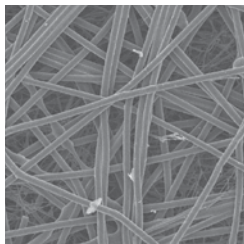

SEM 600X

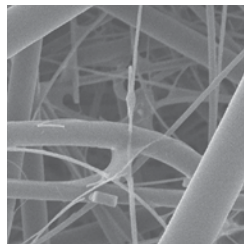

MEDIA IMAGE



HOW IT WORKS

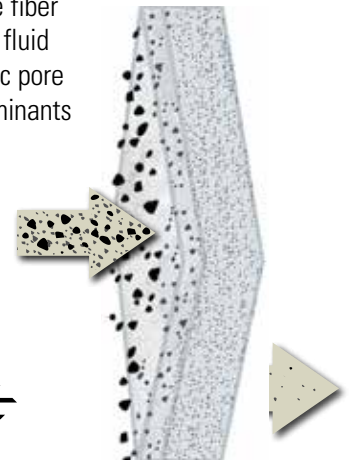

Cellulose Media (Traditional)

Cellulose fibers are actually wood fibers, microscopic in size and held together by resin. Fibers are irregular in both shape and size. Cellulose often has lower beta ratings, which means there are smaller pores in the media. Smaller media pores cause more flow resistance, resulting higher pressure drop.

While cellulose provides effective filtration for a wide variety of petroleum-base fluids, in certain applications it results in poor filtration performance as compared to synthetic media.

SEM 100X

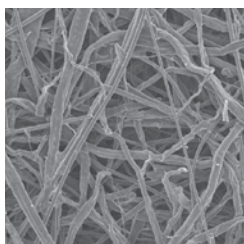

SEM 600X

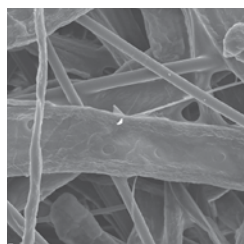

MEDIA IMAGE



HOW IT WORKS

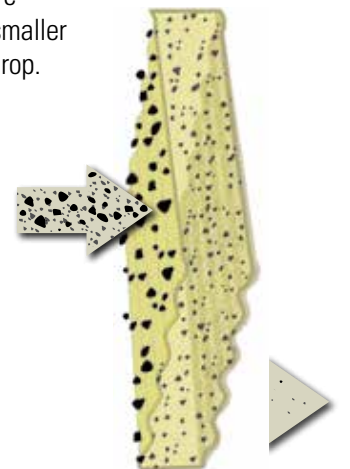



Water Absorbing Media

Water absorption media quickly and effectively removes free water from hydraulic systems. Using super-absorbent polymer technology with a high affinity for water absorption, this media alleviates many of the problems associated with water contamination found in petroleum-based fluids.

HOW IT WORKS

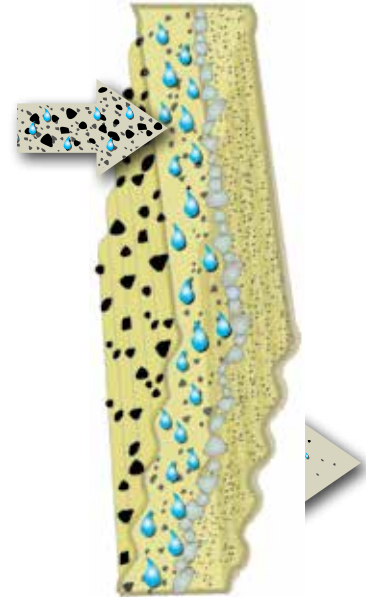

SEM 100X

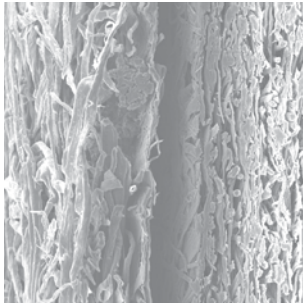

SEM 600X

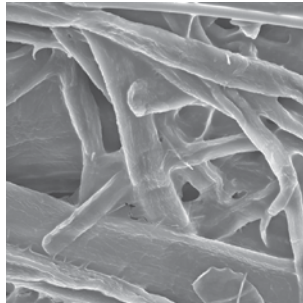

MEDIA IMAGE



Wire Mesh Media

Wire mesh media consists of stainless steel, epoxy-coated wire mesh available in 3 mesh sizes:

- 100 mesh yields 150 µm filtration
- 200 mesh yields 74 µm filtration
- 325 mesh yields 44 µm filtration

Typically wire-mesh filters will be applied to catch very large, harsh particulate that would rip up a normal filter. You may also find this media useful as a coarse filter in viscous fluid applications.

HOW IT WORKS

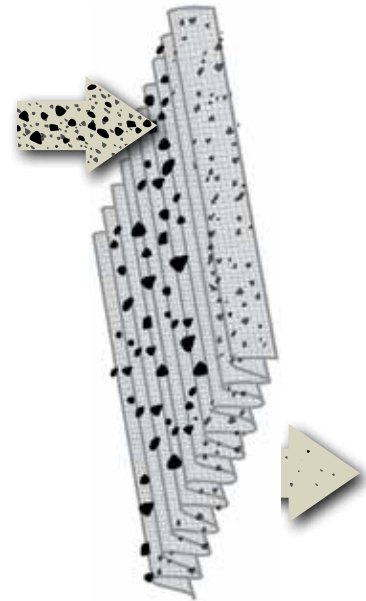

SEM 60X

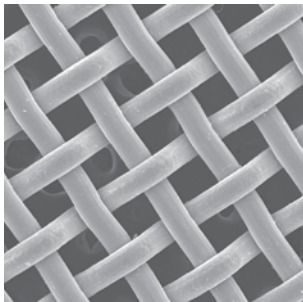

SEM 100X

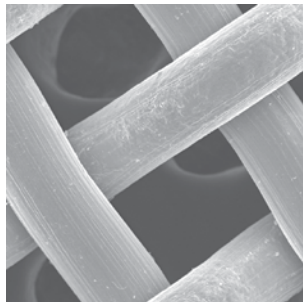

MEDIA IMAGE





Donaldson Filter Media Efficiency Ratings per ISO 23369 Test Standards

ISO 23369 is the international standard for Multi-Pass Testing to determine the efficiency (beta rating or beta ratio) and the dirt-holding capacity of the filter in real world hydraulic cyclic flow conditions.

Donaldson Alpha-Web media has been tested per the new standard and the current alpha ratings are shown. New alpha ratios are shown at 2, 200 and 1000, with a (c) to indicate test adherence to the ISO 23369 standard.

More than 75 percent of all hydraulic system failures can be traced back to contaminated fluid. Today's modern hydraulic systems operate at such high pressures that even microscopic particles can cause wear and tear on components, unplanned downtime, and higher maintenance costs.

Alpha-Web improves hydraulic fluid cleanliness by 2 ISO codes over synthetic media, which is hydraulic fluid 4x cleaner, and According to the Equipment Life Extension Table by Noria Corporation, the industry-accepted authority on fluid cleanliness, an improvement in fluid cleanliness by two ISO codes can extend component life by 60%.

Donaldson Filter Alpha-Web Media Efficiency Ratings Per ISO 23369 Test Standards

$\alpha_{x(c)} = 2$	$\alpha_{x(c)} = 200$	$\alpha_{x(c)} = 1000$
Donaldson Alpha-Web Synthetic Media		
<4 μm	8 μm	10 μm

Fine-Fiber vs. Synthetic Media in Cyclic Conditions

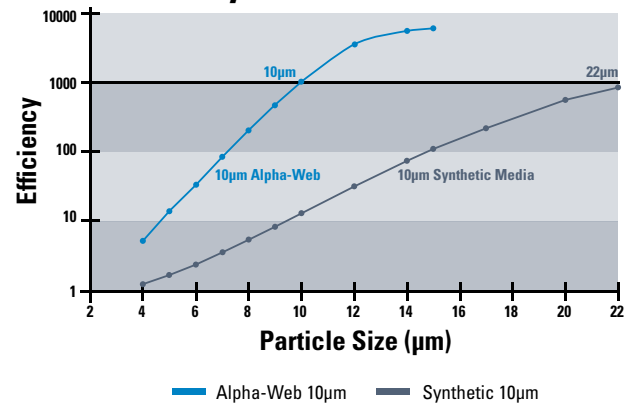

Donaldson's 10 μm Alpha-Web media delivers better efficiencies in cyclic conditions compared to legacy 10 μm synthetic medias. Alpha-Web offers higher efficiency with a lower restrictive pressure drop.

Donaldson's 10 μm Alpha-Web and 5 μm legacy synthetic medias are comparable in efficiency performance. The 10 μm Alpha-Web allows for pressure drop 20% lower than the legacy 5 μm synthetic media. In mobile hydraulic applications where high efficiency is required but restriction is a concern, 10 μm Alpha-Web provides a significant benefit to legacy 5 μm media.

Initial Restriction dP

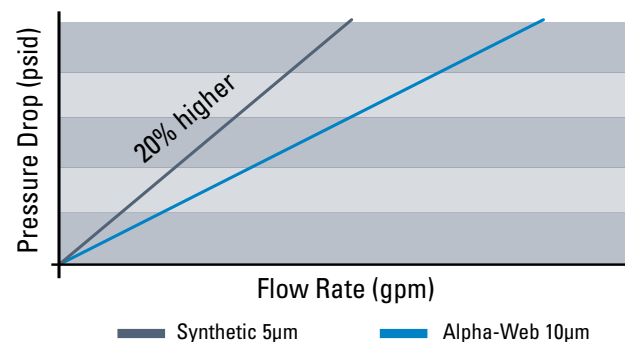

ALPHA-WEB IMPROVES HYDRAULIC FLUID CLEANLINESS BY

2 ISO codes over synthetic media

That's hydraulic fluid up to **4x cleaner***

Which can **extend component life by 60%**

*Results achieved from lab testing. Field testing is ongoing.



Donaldson Filter Media Efficiency Ratings per ISO 16889 Test Standards

ISO 16889 is the international standard for Multi-Pass Testing to determine the efficiency (beta rating or beta ratio) and the dirt-holding capacity of the filter. It replaced the ISO 4572 test standard.

Donaldson filter media has been re-tested per the new standard and the current beta ratios are shown at right. New beta ratios are shown at 2, 200 and 1000, with a (c) to indicate test adherence to the ISO 16889 standard and traceability to NIST test dust.

Fluid to be Filtered	Recommended Media
Petroleum-based	Synteq or Cellulose
Phosphate Ester	DT High-Performance
Diester	Synteq
Water Glycol	DT High-Performance
Water-Oil Emulsion	Synteq
Biodegradable Fluid	Synteq
HWCF (high water content fluids)	Synteq
Coarse Filtration	Wire Mesh

Donaldson Filter Media Efficiency Ratings Per ISO 16889 Test Standards

$\beta_{x(c)} = 2$	$\beta_{x(c)} = 200$	$\beta_{x(c)} = 1000$
Donaldson DT High-Performance Synthetic Media		
<4 μm	<4 μm	<4 μm
<4 μm	<4 μm	5 μm
<4 μm	6 μm	8 μm
<4 μm	10 μm	12 μm
7 μm	18 μm	23 μm
Donaldson Synteq™ Synthetic Media		
<4 μm	<4 μm	<4 μm
5 μm	10 μm	13 μm
6 μm	16 μm	22 μm
7 μm	18 μm	23 μm
14 μm	>42 μm	50 μm
Donaldson Cellulose Media		
5 μm	18 μm	24 μm
7 μm	19 μm	23 μm
17 μm	>40 μm	>40 μm
27 μm	>40 μm	>40 μm
Donaldson Water Absorbing Media		
10 μm		
Donaldson Wire Mesh Media		
45 μm		
60 μm		
75 μm		
90 μm		
125 μm		
150 μm		



Hydraulic Filtration Pressure Drop

The difference between the inlet pressure and the outlet pressure is called pressure drop or differential pressure. It's symbolized by ΔP . ΔP is an irrecoverable loss of total pressure caused by the filter, and is mostly due to frictional drag on the fibers in the media.

Differential drop may increase as the particulate rating or efficiency of the filter (as expressed by its beta ratio) gets better. ΔP also increases as the filter is being loaded with contaminant.

4 Major Factors Contribute to Pressure Drop

1. Filter Media

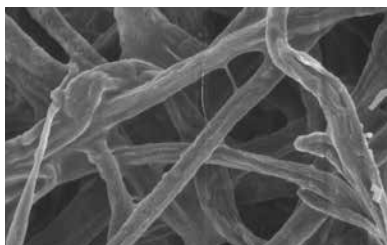

Natural Fiber Cellulose media, as seen under the scanning electron microscope.

Media is, of course, the main factor influencing pressure drop; indeed, it causes pressure drop. That's why having a low-friction, high-flowing media is so important. The natural cellulose or

paper fibers (shown at left) typically used in filtration are large, rough, and as irregular as nature made them.

Donaldson developed a synthetic media with smooth, rounded fibers, consistently shaped so that we can control the fiber size and distribution pattern throughout the media mat, and still allow the smoothest, least inhibited fluid flow. Our synthetic media is named Synteq™.

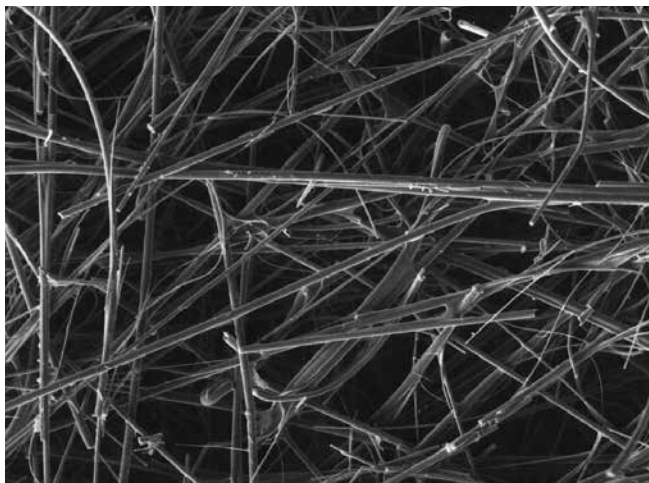

Donaldson's synthetic Synteq filter media — photo from scanning electron microscope — magnified hundreds of times.

Synteq fibers offer the least amount of resistance to fluid passing through the media. Consistency of fiber shape allows the maximum amount of contaminant-catching surface area and specific pore size control. The result is media with predictable filtration efficiencies at removing specified contaminants (e.g., 4 μm) and maximum dirt holding capacity.

Natural cellulose fibers are larger than synthetic fibers and jagged in shape, so controlling size of the pores in the media mat is difficult and there is less open volume. In most applications this results in higher ΔP as compared to synthetic filters. Higher beta ratings mean there are smaller pores in the media; smaller media pores cause more flow resistance, in turn causing higher pressure drop.

2. Dirt, Contaminant

As dirt gets caught in the media, it eventually begins to build up and fill the pore openings. As the pore openings shrink, the differential pressure (pressure drop) increases. This is called restriction. This photo from our scanning electron microscope shows actual dirt particles building up in the media pores.

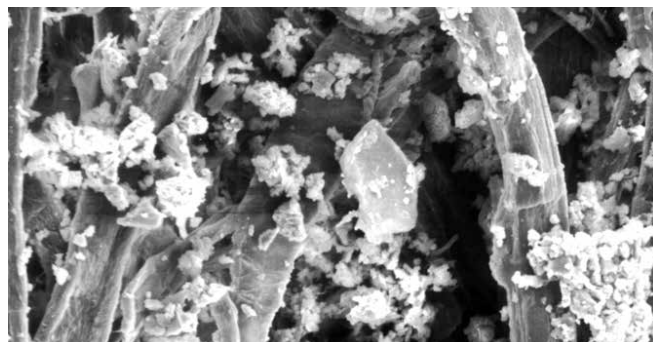

Excessive dirt in the media can cause dirt migration or even filter failure. Dirt migration occurs when the restriction is so great that the differential pressure pushes dirt deeper into the media and, eventually, through the media and back into the system. Filter failure occurs when the restriction becomes so high that the filter cartridge collapses (outside-in flow) or bursts (inside-out flow) to relieve the upstream pressure.

To avoid such catastrophe, use of a filter service indicator is recommended. It measures the pressure drop across the filter, then signals when the filter is 'full' and needs to be changed.

3. Flow

Higher flows create higher pressure drop. With fast moving fluid, there will be more friction causing higher pressure drop across the media.



4. Fluid Viscosity

Measured in centistokes (cSt) or Saybolt Seconds Universal (SSU or SUS), fluid viscosity is the resistance of a fluid to flow. As fluid viscosity increases, the cSt rating increases. Higher fluid viscosities also mean higher pressure drop because the thicker oil has a tougher time passing through the layer of media fibers. Cold start fluid is a good example of highly viscous fluid. See chart below.

Filter media, amount of contamination, the flow rate, and fluid viscosity are all factors in the importance of sizing the filter for the system requirements. Filters that are too small won't be able to handle the system flow rate and will create excessive pressure drop from the start. The results could be filter operation in the bypass mode, filter failure, component malfunction, or catastrophic system failures. Filters that are too large for the system can be too costly. Oversized filters require more system oil and higher cost replacement filters. Optimal sizing is best.

Viscosity Charts

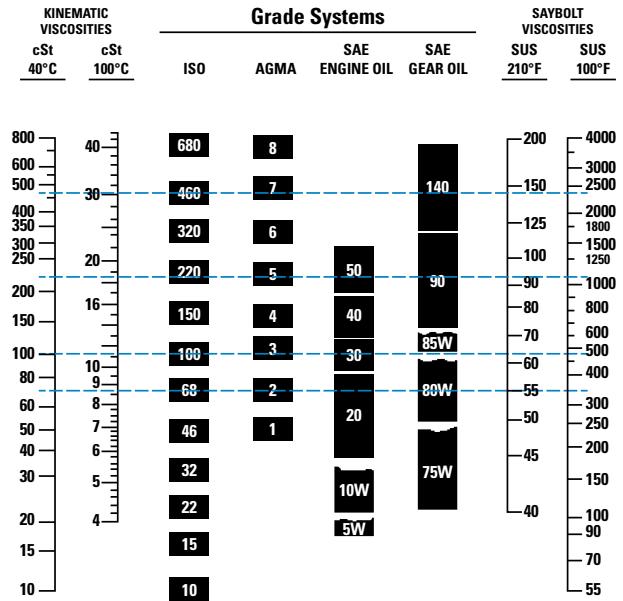

Viscosity/Temperature Chart

A.S.T.M. Standard Viscosity-Temperature Chart for Liquid Petroleum Products (D 341-43) Saybolt Universal Viscosity

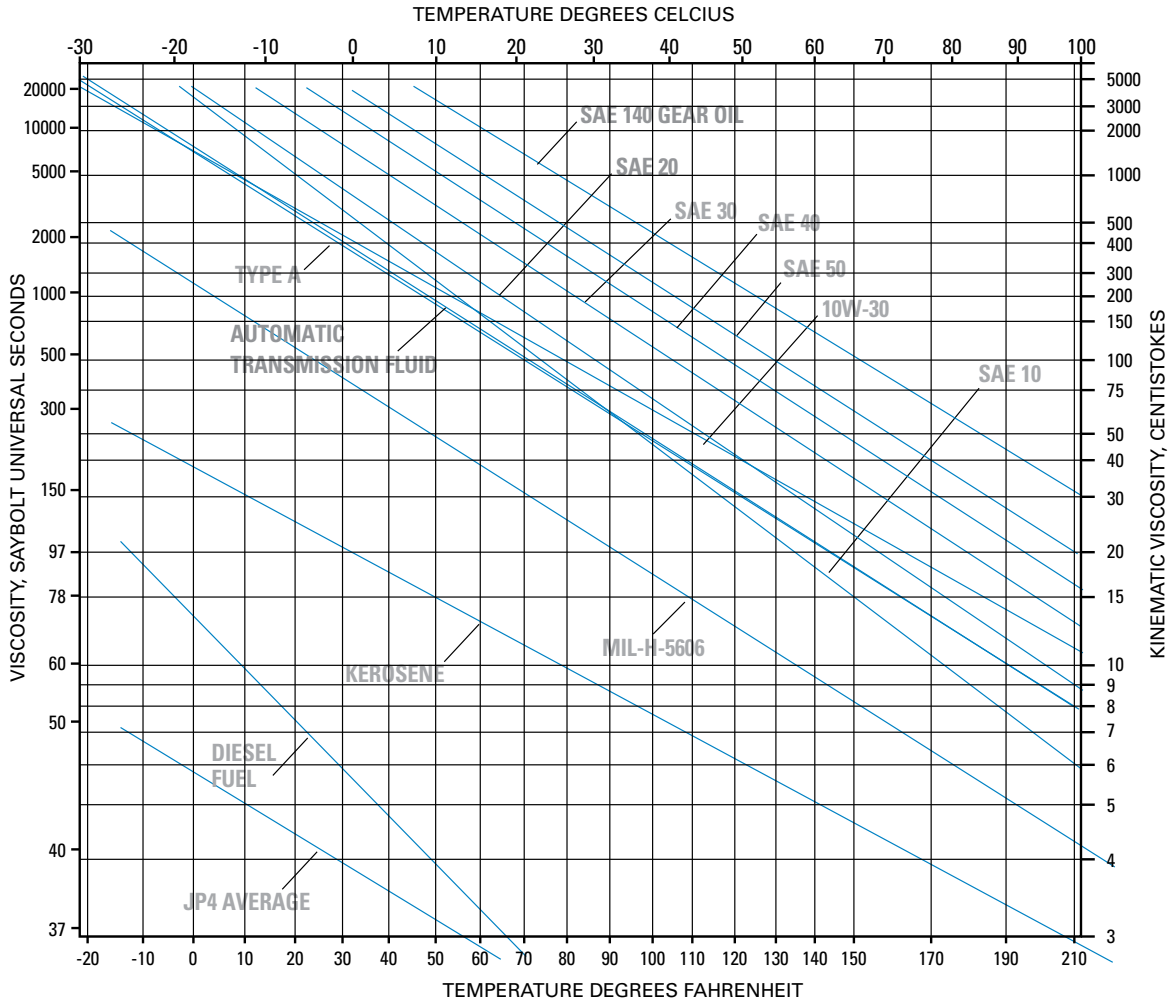

HYDRAULIC FILTRATION TECHNICAL REFERENCE

Filter Design and Construction

There are two main differences in a filter. The first is the design of the filter itself, and the second is the type of media that is used in the filter.

Filter

Filters have some attributes that are immediately obvious to the casual observer, such as height, inside diameter, outside diameter, media concentration, type of liner, seal design, and the way the media and components are glued or potted together.

Liners

Liners must be structurally sturdy to withstand pressure variance, yet open enough to allow good flow.

Seals

The top seal design must be leak-free, with a gasket or sealing device that ensures a good seal throughout the life of the filter. Standard seals are made of nitrile material, which is fine for most applications. However, if the filtered fluid is diester or phosphate ester fluid, you'll need a seal made of a fluorocarbon.

Media Potting

Media potting is key since it holds the media in place in between the end caps (not visible). Not only should the potting be fully around the ends of the media to prevent leaks, it should also be of a material that can withstand the application. For instance, epoxy potting should be used in filters that must perform in higher temperature environments, phosphate ester fluids and some high water based fluids.



Inside the filter, the media can vary in thickness, pleat depth and pleat concentration.

For example, Donaldson hydraulic filters are generally equipped with either white ("Synteq"™ our synthetic material) or natural brown (paper or cellulose material) media. It is important to note that media colors vary according to each manufacturer—it should not be assumed that any white-colored media is made of synthetic material.

Some of the most important characteristics of filter media (structure, fiber diameter, volume solidity, basis weight, thickness, layering) can only be detected under a microscope.



Damaged Equipment

Damage happens when key filtration points are ignored! The pistons in this pump are severely damaged from contamination in the oil.



Combining the ISO Rating and Filter Performance Ratings

While filter manufacturers publish beta ratings for filter media to describe efficiency performance levels, a direct connection between the beta rating scale and the ISO rating scale cannot be made.

The solution is monitoring filter media performance at removing particles in the 4 µm, 6 µm, and 14 µm ranges. Fluid analysis and field monitoring are the only ways to get these measurements. Combine data from several tests to form a range of performance. Remember, actual filter performance will vary between applications.

Here's how to determine which filter media will best protect your hydraulic components: plot any media performance range on the Application Guide (next page) to Donaldson Filter Media, then connect the dots to make a line. On the same graph, plot your component requirement. (Reference chart below for some popular components, or ask your supplier for the recommended ISO rating.) If the line of the media falls below the ISO line, or if the bottom line of the filtration range does not intersect the ISO line, the component will be protected.

Micron Sizes of Familiar Particles	
Grain of table salt	100 µm
Human hair	80 µm
Lower limit of visibility	40 µm
White blood cell	25 µm
Talcum powder	10 µm
Red blood cell	8 µm
Bacteria	2 µm
Silt	<5 µm

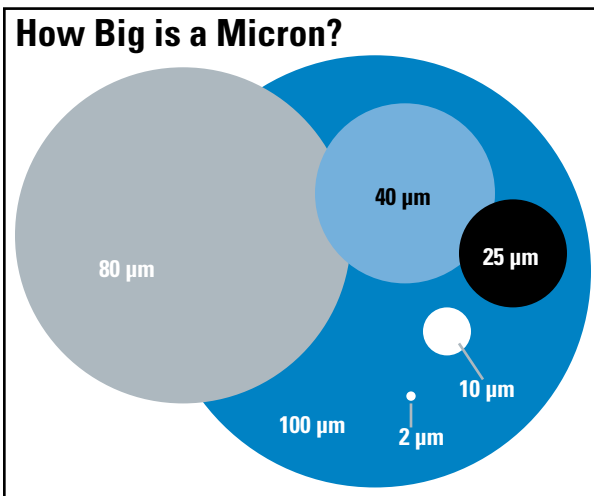

Pressure	<3000 PSI ≤210 Bar	>3000 PSI >210 Bar
Pumps	ISO RATINGS	
Fixed Gear Pump	19/17/15	18/16/13
Fixed Vane Pump	19/17/14	18/16/13
Fixed Piston Pump	18/16/14	17/15/13
Variable Vane Pump	18/16/14	17/15/13
Variable Piston Pump	17/15/13	16/14/12
Valves		
Directional (solenoid)	20/18/15	19/17/14
Pressure (modulating)	19/17/14	19/17/14
Flow Controls (standard)	19/17/14	19/17/14
Check Valves	20/18/15	20/18/15
Cartridge Valves	20/18/15	19/17/14
Load-sensing Directional Valves	18/16/14	17/15/13
Proportional Pressure Controls	18/16/13	17/15/12*
Proportional Cartridge Valves	18/16/13	17/15/12*
Servo Valves	16/14/11*	15/13/10*
Actuators		
Cylinders	20/18/15	20/18/15
Vane Motors	19/17/14	18/16/13
Axial Piston Motors	18/16/13	17/15/12
Gear Motors	20/18/15	19/17/14
Radial Piston Motors	19/17/15	18/16/13

Typical ISO Cleanliness

Here are some typical ISO cleanliness recommendations from component manufacturers. (These are guidelines; always check the ratings specified by the manufacturer of your specific components.)

* Requires precise sampling practices to verify cleanliness levels. Source: Vickers

Media Application Guide and ISO Rating System

The Application Guide for Donaldson Filter Media on the next page provides a data format for rating fluid contamination level and plotting filter media performance.

The vertical numbers on the left side of the chart represent particle counts in a logarithmic progression of ten: 0.01, 0.1, 1, 10, 102, 103, 104, 105 and 106. (This represents the number of particle in the oil sample at the given size.) The numbers across the bottom of the chart represent particle size in microns.

Donaldson media efficiency performance levels are derived from the ISO 16889 test standard with NIST-certified on-line automatic particle counters and ISO medium test dust. The Donaldson media efficiency performance levels shown are based on test averages under steady flow conditions. Actual performance levels may vary by application, viscosity, flow variance and contamination differences. Contact Donaldson or your Donaldson distributor for specific application calculations.

The international rating system for fluid contamination levels is called the ISO contamination code and it is detailed in the ISO 4406 document. Most component manufacturers publish filtration level recommendations using the ISO code. The ISO code, located on the right side of the media application guide on the next page, is easy to use if you remember the 4 μm, 6 μm and 14 μm numbers along the bottom of the chart.

Manufacturer's ISO contamination levels are based on controlling the particle counts of 4 μm, 6 μm and 14 μm particles in hydraulic system oil. This level is identified by measuring the number of particles 4μm and greater, 6 μm and greater, and 14 μm and greater in one milliliter of the system hydraulic oil sample.

How to Use the ISO Rating

Example: A cartridge valve manufacturer recommends an ISO cleanliness level of 18/16/13.

- 1) On the Application Guide for Donaldson Filter Media on the next page, place a dot on the vertical 4 μm line, horizontally even with the 18 box of the ISO code.
- 2) Place a dot on the vertical 6 μm line horizontally even with the 16 box of the ISO code.
- 3) Place a dot on the vertical 14 μm line horizontally even with the 13 box of the ISO code.
- 4) Connect the dots to get the ISO cleanliness level 18/16/13.

As illustrated below, particle counts falling on and above the 18/16/13 line are damaging to the component and exceed the 18/16/13 specification set by the manufacturer.

Select a Donaldson media that falls below 18/16/13 to achieve cleanliness level tolerable to the component.

*In this case, $\beta_{12(C)} = 1000$

ISO 4406 Contamination Code

This correlates to the numbers in the boxes along the right side of the graph on the next page.

Range of number of particles per milliliter:

Code	More Than	Up to & Including	Code	More Than	Up to & Including
24	80,000	160,000	14	80	160
23	40,000	80,000	13	40	80
22	20,000	40,000	12	20	40
21	10,000	20,000	11	10	20
20	5,000	10,000	10	5	10
19	2,500	5,000	9	2.5	5
18	1,300	2,500	8	1.3	2.5
17	640	1,300	7	.64	1.3
16	320	640	6	.32	.64
15	160	320			

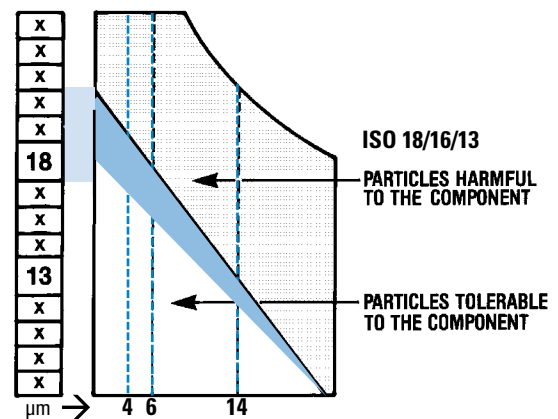



Application Guide for Donaldson Synthetic Filter Media

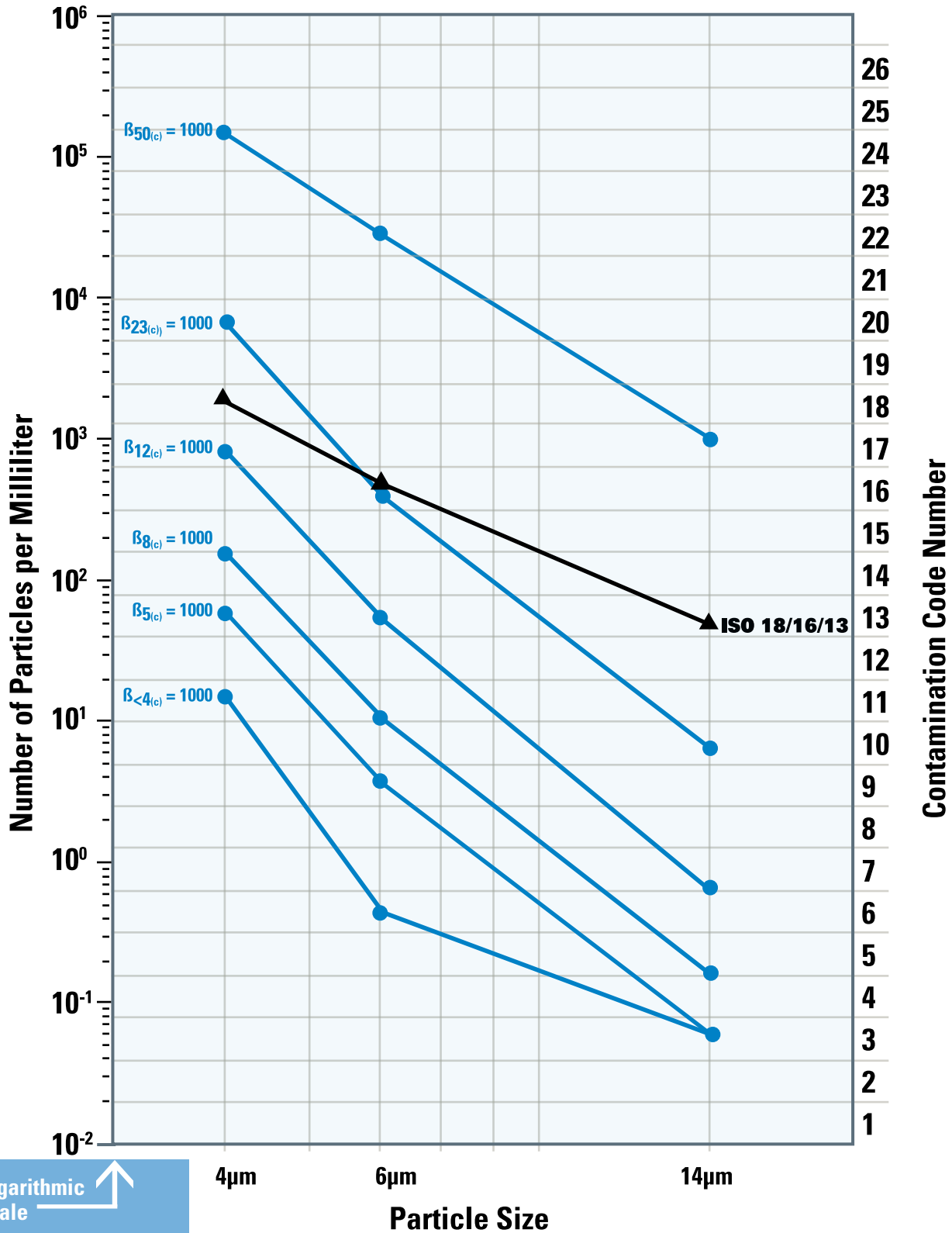

HYDRAULIC FILTRATION TECHNICAL REFERENCE

Logarithmic Scale

This represents the number of particles at a given size in the oil sample



Understanding the Alpha Rating System

This information is provided as an aid to understanding fluid filter efficiency terminology based on current ISO, ANSI and NFPA test standards. It is not proprietary and may be reproduced or distributed in any manner for educational purposes.

What is Alpha Ratio?

Alpha ratio (symbolized by α), similarly to Beta ratio, is a formula used to calculate the filtration efficiency of a particular fluid filter using base data obtained from multi-pass testing. Alpha ratio however is determined from cyclic flow conditions, ISO 23369, whereas Beta is determined from steady flow conditions, ISO 16889. Cyclic flow conditions allow for testing the filtration efficiency in real world hydraulic applications where the flowrate is not constant.

Like beta ratio, the formula used to calculate the alpha ratio is:

$$\text{Alpha ratio}_{(x)} = \frac{\text{particle count in upstream oil}}{\text{particle count in downstream oil}}$$

where (x) is a given particle size

Indicates that testing was done with APC's calibrated with NIST fluid

$$\alpha_{10(c)} = 1000$$

1000 times more particles upstream than downstream that are 10 μm and larger

Find further information on ISO 23369 at www.NFPA.com or your ISO document source. Ask for ISO 23369:2022 "Hydraulic fluid power — Multi-pass method of evaluating filtration performance of a filter element under cyclic flow conditions"

Why the Efficiency Rating Test Standard was Updated?

As anyone who has operated hydraulic equipment knows, steady flow conditions are a rarity in the field. Hydraulics regularly operate under "cyclic flow" conditions, meaning that pressures and flows fluctuate, causing contaminants to dislodge from filter media and re-enter the system, where they cause wear, drops in performance, component failure and eventually, unscheduled downtime of equipment and vehicles. ISO 16889 only required filters to be tested under "steady flow" conditions. Because real-world conditions don't reflect conditions dictated under ISO 16889, in 2021 a new standard, ISO 23369, was introduced as a multi-pass method of evaluating filtration performance in cyclic flow conditions.

shop.donaldson.com

Why the Efficiency Rating Test Standard was Updated?

As anyone who has operated hydraulic equipment knows, steady flow conditions are a rarity in the field. Hydraulics regularly operate under "cyclic flow" conditions, meaning that pressures and flows fluctuate, causing contaminants to dislodge from filter media and re-enter the system, where they cause wear, drops in performance, component failure and eventually, unscheduled downtime of equipment and vehicles. ISO 16889 only required filters to be tested under "steady flow" conditions. Because real-world conditions don't reflect conditions dictated under ISO 16889, in 2021 a new standard, ISO 23369, was introduced as a multi-pass method of evaluating filtration performance in cyclic flow conditions.

The Differences in Steady Flow and Cyclic Flow Testing Methods

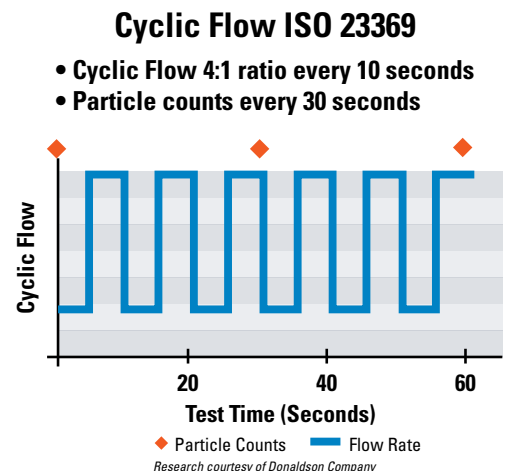
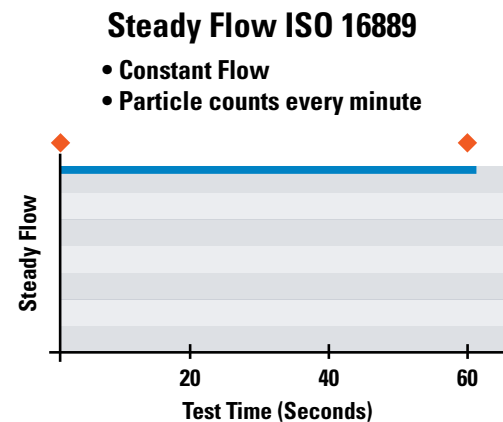



Filter Efficiency Standards

The ISO committee includes members of most of the major oil and lube filtration manufacturers, including Donaldson, which is a major reason the need for additional testing is recognized. No manufacturer wants to be accused of making filters that seem less efficient than advertised, which is what happens to currently approved filters under stress.

ISO developed this cyclic flow multi-pass test procedure for hydraulic filters in order to supplement the basic steady-state flow test of ISO 16889 for filter elements that are expected to be used in cyclic flow environments. Using an industry survey and a round-robin laboratory testing procedure, 16889 guidelines recommend a more stringent flow-rate cycle (0,1 Hz), although it also notes that if much higher cycle rates are expected in actual service, “the test should be conducted at that frequency to produce more meaningful results.” However, only values resulting from testing at the 0,1 will be recognized.

Multi-Pass tests that utilize cyclic flow rate require operators to choose a cyclic ratio of current change, normally between two-to-one or four-to-one. These ratios will stay consistent throughout testing and offer a one-step-closer approach to “real-world” filter performance results by showing the slough or shedding of particles from filters being tested during current changes in the test fluid. The new standard suggests that flow rates (measured in liters per minute) change every five seconds at a four-to-one ratio.

Just as importantly, the test requires fine dust (smaller than 1 micron) versus the medium dust (5 microns or larger) required by ISO 16889. The five-second changes and varying rates mean it’s possible that twice as much data can be recorded, although the data is averaged instead of exact.

Understanding the Beta Rating System

This information is provided as an aid to understanding fluid filter efficiency terminology based on current ISO, ANSI and NFPA test standards. It is not proprietary and may be reproduced or distributed in any manner for educational purposes.

What is Beta Ratio?

Beta ratio (symbolized by β) is a formula used to calculate the filtration efficiency of a particular fluid filter using base data obtained from multi-pass testing.

In a multi-pass test, fluid is continuously injected with a uniform amount of contaminant (i.e., ISO medium test dust), then pumped through the filter unit being tested. Filter efficiency is determined by monitoring oil contamination levels upstream and downstream of

the test filter at specific times. An automatic particle counter is used to determine the contamination level. Through this process an upstream to downstream particle count ratio is developed, known as the beta ratio. The formula used to calculate the beta ratio is:

$$\text{Beta ratio}_{(x)} = \frac{\text{particle count in upstream oil}}{\text{particle count in downstream oil}}$$

where (x) is a given particle size

Indicates that testing was done with APC's calibrated with NIST fluid

$$\beta_{10(c)} = 1000$$

1000 times more particles upstream than downstream that are 10 μm and larger

Find further information on ISO 16889 at www.NFPA.com or your ISO document source. Ask for ISO/TR16386: 1999 “The Impact of Changes in ISO Fluid Power Particle Counting—Contamination Control and Filter Test Standards.”

Efficiency Rating Test Standard Updates

The International Industry Standard (ISO) for multi-pass testing provides a common testing format for filter manufacturers to rate filter performance. This standardization gives you the ability to reliably compare published filter ratings among different brands of filters.

ISO test standards were updated in 1999 to reflect the improved technology available in particle counters and other test equipment. The newer particle counters provide more precise counting and greater detail—reflecting a truer indication of filter performance.

The National Fluid Power Association (NFPA), the National Institute of Standards & Technology (NIST), and industry volunteers, including several engineers from Donaldson, helped revise the ISO standard. ISO 16889 has been in force since late 1999 and ISO 4572 is officially discontinued.

Better Test Dust

The old test dust (AC fine test dust or ACFTD) was “ball milled,” which produced dust particles of varying size and shape. Particle distribution was often different from batch to batch. The accuracy of ACFTD distribution and previous APC calibration procedure was questioned by industry, due to lack of traceability and certification. ACFTD hasn’t been produced since 1992.

Now, the new test dust (ISO medium test dust) is “jet milled” to produce consistent particle size, shape, and distribution from batch to batch. See dust size comparison chart on the next page.



Liquid Automatic Particle Counters (APC's)

In the old test standard (ISO 4572), fluid samples obtained in bottles and off-line particle counting were allowed. Now, in the updated standard (ISO 16889), on-line, laser-based automatic particle counters, especially made for measuring liquids, are required and bottle counting methods are disallowed, as illustrated below. The old particle counter calibration was based on only one dimension of an irregularly-shaped particle (the longest cord). Today, the particle counter calibration is based on equivalent spherical area of an irregularly-shaped particle.

NIST provides calibration suspension, which is certified with X number of particles at a certain

size. This is verified by NIST. The new way to list beta ratios includes a subscript (c) to indicate NIST certified test suspension and assures you of traceability and repeatability.

Overall, you can have strong confidence in filter ratings resulting from tests per ISO 16889, as they are highly accurate. As always, keep in mind that beta ratings are laboratory measurements under steady flow conditions with artificial contaminants — the real proof of the performance is how clean the filter keeps the fluids in the application. A good oil analysis program that checks the cleanliness of the oil periodically will verify that the proper filters are being used.

Test Dust Size Comparisons

ACFTD calibrated size (μm) per ISO 4402 corresponds to a NIST-calibrated size [$\mu\text{m}_{(c)}$] per ISO 11171

ACFTD	0.8	1	2	2.7	3	4.3	5	7	10	12	15	15.5	20	25	30	40	50
NIST	4	4.2	4.6	5	5.1	6	6.4	7.7	9.8	11.3	13.6	14	17.5	21.2	24.9	31.7	38.2

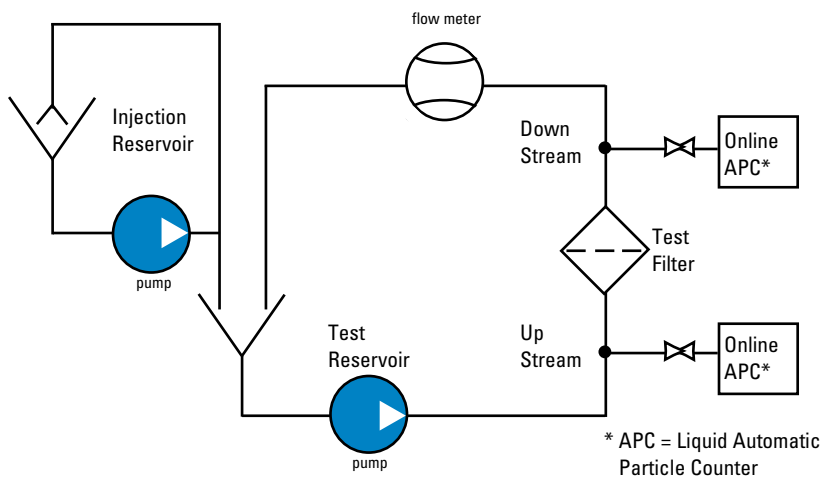

ISO 16889

- In-Line Liquid Automatic Particle Counters (APC) are now required for proper testing.
- APC calibration follows ISO 11171 procedures
- ISO 11171 uses NIST (National Institute of Standards & Technology) certified calibration fluid

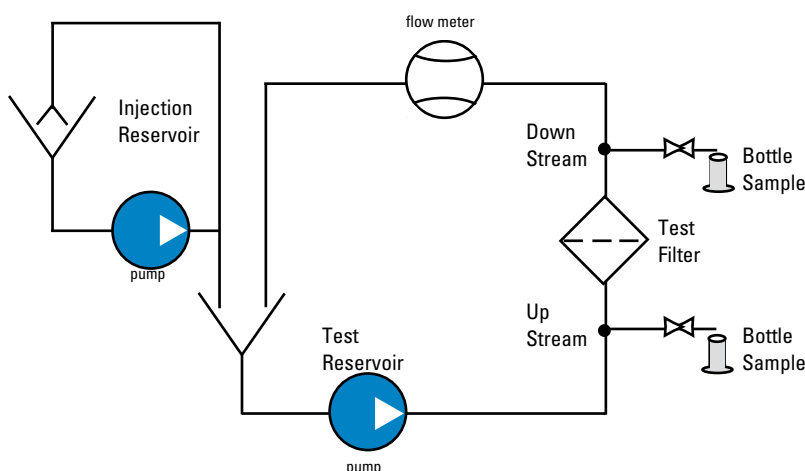

ISO 4572

(Discontinued)

- Either bottle samples or APC's were allowed.
- APC calibration followed ISO4402 ACFTD (Discontinued)



Highlights of ISO 16889

- ISO 4572 is now replaced by ISO 16889 as the international standard for Multi-Pass Tests to determine the efficiency (beta rating or beta ratio) and the dirt-holding capacity of the filter.
- The test bench for ISO 16889 must have On-Line Liquid Automatic Optical Particle Counters (APC) calibrated using NIST (National Institute of Standards & Technology)-certified calibration fluid. This includes added enhancements to APC's, to allow for better resolution, accuracy, repeatability and reproducibility.
- ISO 12103-1,A3 (ISO Medium, 5 µm - 80 µm)
- Test Dust was selected as replacement dust for calibration and testing procedures.
- APC's are calibrated by passing a sample of calibration fluid with a known particle size distribution and producing a calibration curve to match the known count distribution.
- NIST used the Scanning Electron Microscope analysis and statistical analysis techniques to certify the particle size distribution.
- Particle counts, upstream and downstream, are taken every minute of the test.
- Beta ratios are reported with (c) to designate NIST traceability.

ISO 16889 recommends reporting beta ratings at:

Rating	Efficiency
2	50%
10	90%
75	98.7%
100	99%
200	99.5%
1000	99.9%

Example: $\beta_{4(c)} = 200$ signifies that there are 200 times as many particles that are 4 µm and larger upstream as downstream. This is **99.5% efficiency**.

Example: $\beta_{5(c)} = 1000$ indicates that there are 1000 times as many particles that are 5 µm and larger upstream as downstream. This is **99.9% efficiency**.

Donaldson Hydraulic Filter Media Beta Ratings

Donaldson hydraulic filter media beta ratings are average ratings obtained from multi-pass tests performed per the new ISO 16889 standard.

According to the ISO standard, each filter manufacturer can test a given filter at a variety of flow rates and terminal pressure drop ratings that fit the application, system configuration and filter size. Your actual performance may vary depending on the configuration of the filter tested and test conditions.

Donaldson Filter Media Efficiency Ratings Per ISO 16889 Test Standards		
$\beta_{x(c)} = 2$	$\beta_{x(c)} = 200$	$\beta_{x(c)} = 1000$
Donaldson DT High-Performance™ Synthetic Media		
<4 µm	<4 µm	<4 µm
<4 µm	4 µm	5 µm
<4 µm	6 µm	8 µm
<4 µm	9 µm	12 µm
7 µm	18 µm	23 µm
Donaldson Synteq™ Synthetic Media		
<4 µm	<4 µm	<4 µm
5 µm	10 µm	13 µm
6 µm	16 µm	22 µm
7 µm	18 µm	23 µm
14 µm	>42 µm	50 µm
Donaldson Cellulose Media		
5 µm	18 µm	24 µm
7 µm	19 µm	23 µm
17 µm	>40 µm	>40 µm
27 µm	>40 µm	>40 µm
Donaldson Water Absorbing Media		
10 µm		
Donaldson Wire Mesh Media		
45 µm		
60 µm		
75 µm		
90 µm		
125 µm		
150 µm		



Cleanliness Level Correlation Table

Conversion of cleanliness specifications to filter performance is not an exact science because the contamination level in a hydraulic system is a function of the ingress and generation rate as well as the filter performance.

Factors That Affect Cleanliness Levels in a Hydraulic System

- Abrasive wear in space between adjacent moving surfaces of components.
- Erosive wear at component edges or direction changes where there is high fluid velocity.
- Fatigue wear by particles trapped between moving surfaces.

Identification of the Most Sensitive Component

- Required cleanliness level is dominated by the component with smallest clearances and/or highest loading on the lubricating film.
- Best source for determining this level is the specification published by the component manufacturer.
- Higher pressures reduce component life, unless contamination level is decreased accordingly.
- Operating at half the rated pressure of component will increase its life by more than four times.
- Percent of operating time at maximum pressure depends on individual machines and application.

ISO Code	Particles Per Milliliter >10 microns	ISO FTD* Gravimetric Level (mg/l)	Mil Std 1236A (1967)	NAS 1638 (1964)	SAE Level (1963)
30/26/23	140,000	1000			
29/25/23	85,000		1000		
26/25/20	14,000	100	700		
23/21/18	4,500			12	
2220/18	2,400		500		
22/20/17	2,300			11	
21/20/17	1,400	10			
21/19/16	1,200		10		
20/18/15	580			9	6
19/17/14	280		300	8	5
18/16/13	140	1		7	4
17/15/12	70			6	3
16/14/12	40		200		
16/14/10	35			5	2
15/13/10	14	0.1		4	1
14/12/9	9			3	0
13/11/8	5			2	
12/10/8	3		100		
12/10/7	2.3			1	
11/10/6	1.4	0.01			
11/9/6	1.2			0	
10/8/5	0.6			0	
9/7/5	0.3		50		
8/6/3	0.14	0.001			
7/5/2	0.04		25		
6/2/.8	0.01		10		

* SAE Fine Test Dust — ISO approved test and calibration contaminant.
Source: Milwaukee School of Engineering Seminar, Contamination & Filtration of Hydraulic Systems



Compatibility of Donaldson Filter Media with Hydraulic Fluids

While Donaldson has developed many formulations of media, they can be divided into two broad categories: natural fibers, usually cellulose, and synthetic or man-made fibers.

Recommended Filter Media

Petroleum-Based (Hydrocarbon) Fluids	Cellulose	Synteq	DT High-Performance
Straight oils	Yes	Yes	Yes
ATFs	Yes	Yes	Yes
Military hydraulic fluids	Yes	Yes	Yes
#2 Diesel fuel	Yes	Yes	Yes
Gasoline	Yes	Yes	Yes
E85 (85/15 Ethanol/Gasoline)	No	No	Yes
Fire Resistant Fluids	Cellulose	Synteq	DT High-Performance
HFA - Oil-in-water emulsion	No	<150°F	Yes
HFB - Water-in-oil emulsion	No	<150°F	Yes
HFC - Water glycol	No	<150°F	Yes
HFD Synthetics - Polyol esters, Esters, Diesters, & blends	No	Yes	Yes
HFD Synthetics - Phosphate esters	No	No	Yes
HFD Synthetics - Polyalkylene glycols (PAG), Polyalphaolefins (PAO), & blends	No	Yes	Yes
HFD Synthetics - Silicone (siloxane) oil	No	Yes	Yes
Biodegradable Fluids	Cellulose	Synteq	DT High-Performance
Vegetable-based oils - sunflower, rapeseed oils	No	Yes	Yes
Synthetic oils - PAG / PAO	No	Yes	Yes
Synthetic oils - Esters, Diesters	No	Yes	Yes



Piston Pump Damage

The severe score marks on the piston slippers leave no question about why good hydraulic filtration is important.



A Note on Seals

- Filters with seals made of nitrile are appropriate for most applications involving petroleum oil and some high water content fluids. Filters with seals made of fluorocarbon are required when using diesters, phosphate ester fluids. Donaldson offers both types. EPR (ethylene propylene rubber) seals are required for use with Skydrol® and Skydrol 500 fluids.
- In Donaldson filters with fluorocarbon seals, epoxy potting is used to accommodate higher temperature environments and for compatibility with fluids such as phosphate ester, diesters, and high water based fluids. The plastisol (heat cured) and urethane (self curing) potting materials used in other filters perform well with petroleum-based fluids.
- Seal installation instructions are included with relevant products, as well as the product page in the Hydraulic Filtration Product Guide.

Watch Out for Old Compression Gaskets!

A compression seal is a means of preventing migration of liquids, gases or solid contaminants across a joint or opening in an assembly or housing. A seal not only prevents the escape of fluid from inside and foreign material from entering the system from outside, but it must provide for easy installation and removal. A new gasket is critical for proper filter function. Remember:

1. Remove used gaskets and thoroughly clean the sealing area
2. Always use a new gasket with a replacement filter
3. Over-tightening the filter may damage the head
4. Dispose of used filters properly

General Service and Installation Tips

When installing and servicing your liquid spin-on filters, follow these general rules of thumb:

Do not over-tighten

- Do not use tools or filter wrenches to install filters – this may cause damage to the filter, resulting in poor filter performance or leaks
- Do not use grease to lubricate the gasket
- Check and inspect the condition and security of the threaded spigot
- Dispose of any used oil or fuel filters in a safe and proper manner in accordance with local, state, and federal regulations

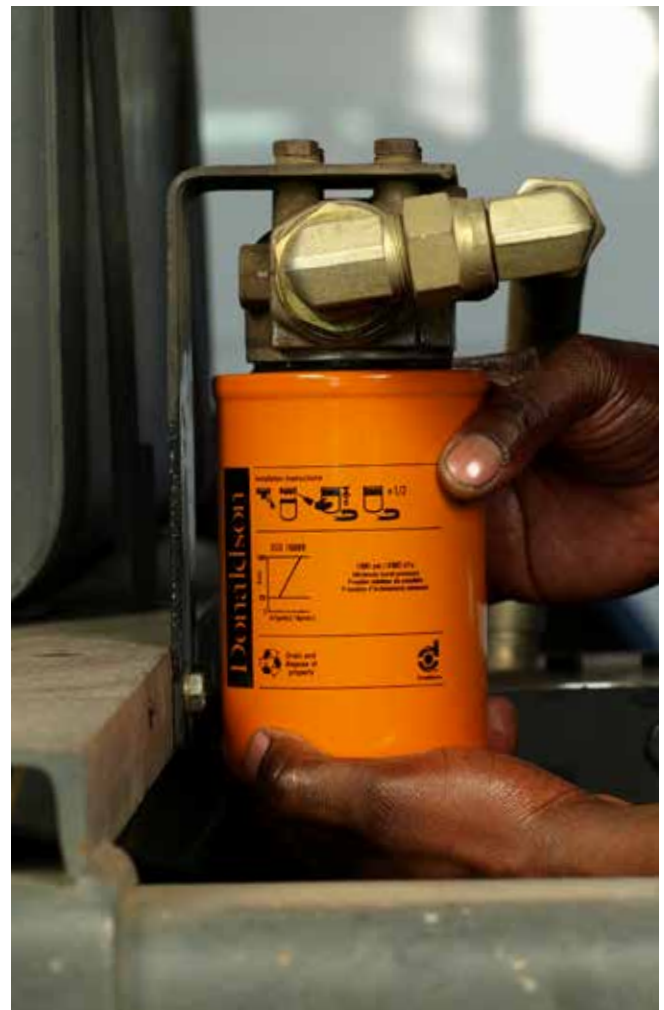

When changing any filter that has a gasket — use caution as old gaskets may stick!



How to Best Position Filters in Your Hydraulic Circuit

Within every hydraulic circuit there are many possible places for filters.

The best systems are strategically engineered to ensure that oil is filtered properly at each stage of its journey through the circuit. Ideally, filtration should occur in the following places:

- In the Reservoir
- Before/After the Pump
- In the Return-line System
- Off-line

In reality, many companies have to make tough decisions about which filters they can afford and which ones they'll have to live without.

Much depends on the cleanliness level requirements of the components, environment, duty cycle of the equipment and other variables that can vary from application to application.



Portable Kidney Loop Filter Cart

Kidney Loop Filters

Benefit: High

Sometimes referred to as "off-line" filters, kidney loop filters achieve very fine filtration by maintaining steady-state flow, independent of the hydraulic circuit.

With this type of filtration, the entire hydraulic system can keep operating while the kidney loop filter is being serviced.

A kidney loop filter utilizes low-pressure housings that are easily accessible and serviceable. These filters can either be integrated into the main hydraulic reservoir, or used in mobile filter carts like the one shown at left to service many hydraulic systems.

Note that kidney loop filters do not directly protect components — rather, their main function is to polish the oil to a very clean condition. It's also important to remember that an additional pump and motor will be required.

Filler / Breather

Benefit: High

Tank breathers are placed on hydraulic reservoirs to prevent atmospheric contamination from entering and to allow for sufficient air movement inside the reservoir.

Breathers should prevent particles larger than 3 microns from entering the system. This is a sensible, affordable solution for any hydraulic system, but by all means cannot be the only filter on a hydraulic system.



This diagram shows how various types of filters can be used in hydraulic circuits.

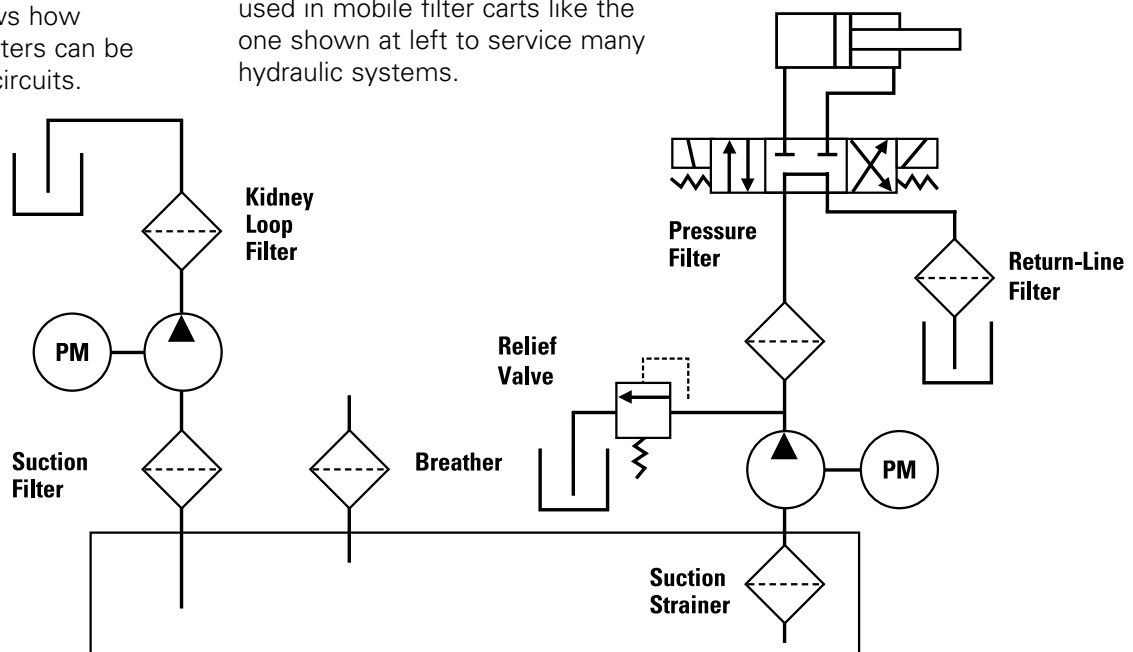



Suction Filter

Benefit: Medium

Normally placed between the reservoir and the pump, suction filters are designed to remove particles in the 5 to 150 micron range. They are easier to service and less expensive than many other types of filters—but because restriction in the suction line must be kept very low, filter housing size tends to be larger than similar flow return or pressure filter housings.

The most popular application for suction filters is with variable-speed hydrostatic pumps commonly found in off-road mobile applications and industrial variable-speed drives. They are also often used in harsh environments and charge pump applications.

Suction Strainer

Benefit: Low

Suction strainers, or sump-type filters, are often used in hydraulic fluid reservoirs. Their only real use is to keep cigarette butts, moths, nuts & bolts and the like out of the pump. Instead, such contaminants can easily be eliminated by keeping the reservoir sealed and by using a Filler/Breather and Return-Line Filter.

Return-Line Filter

Benefit: High

The advantages of return-line filters are many. They are usually low-pressure housings, which are typically less expensive. Their purpose is to collect the dirt from around the circuit as the oil returns to the reservoir. Much like the kidney loop, the return-line filter provides ultimate flexibility in positioning — it can perform almost anywhere within the return line circuit, either mounted inline or built into the reservoir.



Downsides are few, but worth noting: return-line filters can be subject to flow surges (which contribute to poor filter performance) and they do not filter the drain lines.

Note regarding return-line and kidney-loop filtration:

If you're looking for a great value filter that's easy to maintain and with lots of media choices, this is a wise investment. Although these filters are very common, one downside is that there are very few standards of consistency from one manufacturer to the next, so replacement cartridges are not necessarily interchangeable.

Pressure Filter

Benefit: High

This is also known as “last-chance” filtration. High pressure filters keep clean the oil that comes directly from the pump so that the more expensive downstream components (such as valves and actuators) are protected. Pressure line filters offer protection from catastrophic pump failure. They are a worthwhile investment for high-value systems — as are found in the aircraft industry, paper and steel mills, plastic injection molding, and in die-casting machines.



One downside to high pressure filters is, ironically, the high pressure. The entire system must be stopped in order to service a high-pressure filter — unless a duplex configuration is used. When oil is shooting out of a pump at 6000+ psi, it will take out anything in its way! By nature, a high-pressure pump is a prime mover of fluids, so it will experience significant wear over time. Service can also be more difficult because of its heavy-duty construction—as anyone who's ever tried to change a slippery, 200-pound cast-iron filter can attest.



Do Not Use Dented or Damaged Filters



Dents in a steel filter canister create a concentration of stress—making the canister more susceptible to fatigue.

Filters that are dented prior to or during installation should not be used. Filters damaged while in service should be replaced immediately.

Dents May Cause Cracks

Cracked filters can be caused by dents made during improper installation. Filters that are dented prior to or during installation should not be used. Filters dented after installation should be replaced immediately. The cost of replacing a dented filter is much less than the cost of the damages that could result from a dented filter that fails during service.

Filter fatigue results from pressure pulses within the system. Pressure is regulated by a pressure regulating valve. This valve is spring operated and intermittently opens and closes to regulate pressure. Once pressure exceeds the setting of the spring in the regulating valve, the valve will open and relieve pressure until the spring can expand and close the valve. This function is repeated continuously during operation of the system, creating a pulsing effect. Filter canisters are subjected to the same pulsation. However, unlike the spring in the pressure regulating valve, canister material is susceptible to failure after such fatigue.

Filters are designed with a low carbon steel to resist fatigue and are formed so the stress created by the pulses in the system are equalized over the surface area of the canister. A dent provides an area of stress concentration where pressure pulses can greatly shorten the fatigue life of the canister.

If you receive filters that were dented prior to your receipt, you should contact Donaldson customer support for corrective action.

Storage and Handling of Filters On-Site

Whether it's an empty trailer or building, it's important to practice good storage and handling techniques when it comes to filters. Always store filters in their original packaging and cartons in a cool, dry, contamination-free environment. Before installing any filter on a piece of equipment make sure the filter is clean, unused and free of damage.

Filter Storage Tips and Recommendations for Contamination Control

- Check the condition of the element prior to fitting. Check the exterior of filter for signs of damage, and check the inside of the filter element for visible contamination.
- Never store a filter on a shelf without it being in a box or totally sealed from outside contaminant.
- When you see an open box of filters on the shelf, tape it shut—unless the filters inside the box are individually sealed.
- Handle filters with care to prevent filter damage; for example, don't throw filters into the back of a truck.
- If transporting filters from one job site to another, don't let them roll around on the floorboard or in the back of a truck as it may damage the filter.
- Metal storage shelves may cause condensation to form on filters if sitting directly on metal. Over time the filter may get rusty. This is another good reason to store filters in boxes.
- If a product box has layers of contaminant, take care that the contaminant doesn't get on the new filter as you remove it from the box.
- Practice "first-in, first-out" with your inventory. When possible, always use the oldest inventory first.
- Make sure labels with product information and manufacturing dates are visible to personnel selecting from the shelves.

Typical Hydraulic Circuit and Filter Locations

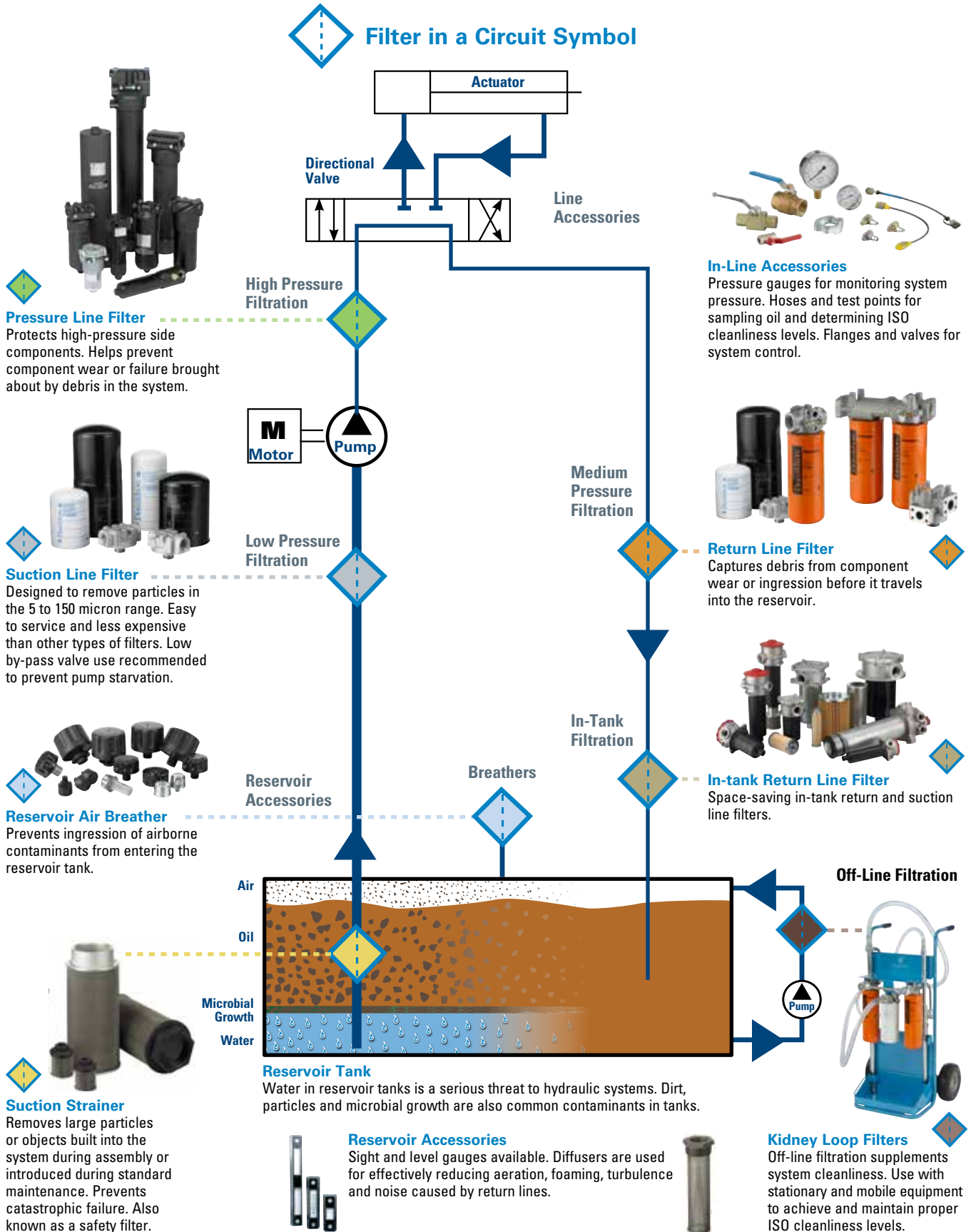



Maintenance Practices for Contamination Control

Here are recommended practices from Donaldson about hydraulic filter servicing and handling. These steps are universal to many hydraulic systems. This servicing information is provided as a best practices guide. Donaldson recommends that where possible, follow the filter service instructions supplied by your original equipment manufacturer. It is not however intended to replace or supersede the service instructions supplied by your equipment or vehicle manufacturer.

Spin-On Filter Servicing



Check the filter service indicator.

- Check to see that the OEM specified service interval has been reached or that the service indicator shows that the filter is due for servicing.



Turn system off and release pressure.

- Ensure that the hydraulic system is turned off.
- Check that there is no pressure present.



Unscrew and remove old filter and gasket.

- Properly dispose of the filter as may be required by local regulations or recycle it.



Wipe filter head with clean cloth.

- Clean the filter head or cover surfaces
- When performing a hydraulic oil change, it is best to use a clean cloth.



Inspect the new filter for damage.

- Check the new filter you will be installing for any shipping and handling damage.
- Do not install a dented filter since the canister has been weakened.



Lubricate the threads.

- Lubricate threads of filter head.

Failure to do this could result in thread galling



Apply thin film of clean oil to gasket.

- Lubricate seal(s) with clean oil.



Align threads. Spin filter until gasket contacts.

- Spin the new filter on until the top of the gasket first contacts the sealing surface.



Hand tighten the filter.

- Tighten per the guidance of the icons which appear on the filter housing. Do not over-tighten.



Bleed the system and check for leaks.

Filter Installation and Servicing Icons



Donaldson spin-on filters have pictograms on the sides to define the proper servicing steps.



Cartridge Filter Servicing



Check the filter service indicator.

- Check to see that the OEM specified service interval has been reached or that the service indicator shows that the filter is due for servicing.



Turn system off and release pressure.

- Ensure that the hydraulic system is turned off.
- Check that there is no pressure present.



Unscrew the cartridge housing.



Remove the used filter and gasket, if applicable.



Clean out the housing seal area and cap.

- Clean out any sediment from the inside of the filter housing.
- Properly dispose of the cartridge according to local regulations.

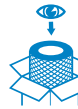

Inspect the new filter cartridge for damage.

- Check the new filter you will be installing for any shipping and handling damage.



Lubricate seals, gaskets and threads. Install new cartridge.

- Lubricate the o-rings, gaskets, housing seals and threads with clean oil.



- Install filter into the housing.



Align threads. Spin filter until gasket contacts.

- Fit the housing to the filter head as instructions on the housing.



Hand tighten the filter.

- Tighten per the guidance of the icons which appear on the filter housing.
- Do not over-tighten.



Bleed the system and check for leaks.



In-tank Filter Servicing



Check the filter service indicator.

- Check to see that the OEM specified service interval has been reached or that the service indicator shows that the filter is due for servicing.



Turn system off and release pressure.

- Ensure that the hydraulic system is turned off.
- Check that there is no pressure present.



Remove the housing cover.

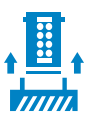

Remove the used filter, gasket and spring, if applicable.

- Remove the filter as gently as possible.
- Avoid contaminant dropping into the clean side of the housing.
- Properly dispose of the cartridge, seal and spring.



Clean the filter mount, cap, inside of the housing and cover.

- Clean out any sediment from the inside of the filter housing.



- Wipe away any sediment on the outside of the filter cover.

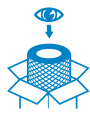

Inspect the new filter cartridge for damage.

- Check the new filter you will be installing for any shipping and handling damage.



Lubricate the filter gasket and cover seal.

- Lubricate the new filter cartridge O-ring and cover seal with clean oil.

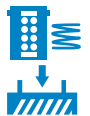

Install new filter and spring, if applicable.



Reinstall the housing cover.

- Refit the cover following any instructions given.



Bleed the system and check for leaks.

Filtration Service Videos Now on YouTube®!

www.youtube.com/user/donaldsonengine

Thirty Donaldson Academy filter servicing videos are now available as a resource for understanding filtration selection and maintenance. They cover detailed hydraulic filter service steps and best practices. Air, lube, fuel and coolant training modules are also available.

These videos are easily accessible from smart phones – making them a great tool for mobile training!

YouTube® is a registered trademark of Google Inc.



SERVICE TRAINING VIDEOS



youtube.com/user/donaldsonengine

donaldson.com



HYDRAULIC FILTRATION FOR VEHICLES/EQUIPMENT APPLICATION DESIGN WORKSHEET

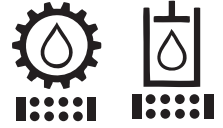

For proper development/design engineering solution, we ask you to provide details about your engine, project due dates, hydraulic or transmission system and performance (mechanical and filtration), system

mounting, service, final packaging and product markings. When completed, please forward to Donaldson. Email: engine@donaldson.com

Customer Name:		Revision:
Project Name:		
Contact Name:		Title:
Phone:	Fax:	Email:
Current Donaldson Model Used: (if applicable)		Customer Part Number:
Target Cost:		

Project Details

Type of Vehicle/Machine: _____
Units Per Year: _____
Key Project Dates:
 Design Proposal: _____
 Quote: _____
 Sample Delivery: _____
 Design Freeze: _____
 PPAP: _____
 Start of Production: _____

Application Information

Components That Need Protection

Pump (type?): _____
 Circuit: Hydraulic Pilot
 Transmission: Hydrostatic Powershift

Filter Location:

Suction Pressure Return
 Side Loop Charge Sump
 Other: _____

Port Size & Type:

NPT: 1/2" 3/4" 1-1/4" 1-1/2" 2-1/2"
SAE O-ring: -8 -12 -16 -20 -24
4 Bolt Flange: 2" SAE 3" SAE 4" ANSI
 2" Code 61 2-1/2" Code 61
BSP: 1/2" 3/4" 1"
Other: _____

Mounting Requirements:

Operating Conditions

Flow Rates: lpm or gpm
 Minimum _____ Normal _____ Maximum _____
Oil System Pressure (psi/kPa):
 Minimum _____ Normal _____ Maximum _____
Temperature: °C or °F
 Fluid: Min _____ Normal _____ Max _____
 Ambient: Min _____ Normal _____ Max _____

Fluid Type:

Petroleum Water-glycol
 Phosphate-ester HWBF
 Other _____

Viscosity: (2 required)

_____ cSt or Ssu @ _____ °C Temp
 _____ cSt or Ssu @ _____ °C Temp

Filtration Performance

ISO Contamination Level Required:

 Beta_{x(c)} = 1000: _____ μm
 Filter Media: Synthetic Cellulose Wire Mesh
 Capacity:
 _____ gms ISO Medium @ _____ flow to _____ psid/kPaD

More on next page

Pressure Drop Limits:

Limits	psid/kPaD		Flow (gpm/lpm)		Viscosity
1		@		@	
2		@		@	
3		@		@	

Structural Performance**Hydrostatic Pressure Resistance (Burst):**

Test Method: _____

Minimum Value: _____ psi / kPa

Collapse Pressure:

Test Method: _____

Minimum Value: _____ psid / kPaD

Pressure Testing:

	Min. Cycles	Range (psid)	Frequency (Hz)
Hydrodynamic		to	
Flow Fatigue		to	
Vibration		to	

By-Pass Cracking Pressure

Test Method: _____

Minimum Value: _____ psid / kPa

By-pass Valve: In Head In Filter

Setting: _____ psi / kPa

Leak Testing

Test Method: _____

Minimum Value: _____ psid / kPa

Initial Product Cleanliness

Specification/Requirement: _____

Additional Information**Filter Service**Indicator Type: Electric Visual

Type: _____

Indicator Level: _____ psid/kPaD

Filter Change Interval:_____ km or miles or hoursDo you require installation, service or maintenance recommendations from Donaldson? Yes No**Packaging****Do you have any special packaging requirements?** Yes No If yes, please check all that apply:Protective caps: on inlet on outlet on port**Final Assembly:** Bulk / Bagged Bulk/Individual Boxes Other _____**Product Markings/Identity****Do you have any product marking requirements?**Head Assembly? Yes NoFilters? Yes No

If yes, artwork it is assumed customer will provide artwork for filter markings. Donaldson can provide marking area for artwork design. Standard installation icons are available from Donaldson.

Special Requirements or Application Notes

Use this area to provide additional information that will assist Donaldson engineering.

For Donaldson Use Only

Date Received: _____

Request From: Catalog Web Other _____**Assigned to:**

Business Unit: _____

Account Manager: _____

Product Manager: _____

Engineer: _____



Donaldson Company, Inc.
PO Box 1299
Minneapolis, MN 55440-1200

Hydraulic Applications Engineering

F115354 (06/17) Rev.3

©2017 Donaldson Company, Inc. All rights reserved. Printed in the U.S.A.
Donaldson Company, Inc. reserves the right to change or discontinue any model or specification at any time and without notice.

Donaldson Company, Inc., PO Box 1299, Minneapolis, MN 55440-1299

Easy.



Easier.



NOW YOU CAN SHOP FOR DONALDSON REPLACEMENT FILTERS ONLINE.

Visit shop.donaldson.com on your computer, phone or tablet to find all your top-quality aftermarket filters including fuel, lube, coolant and air intake filters for diesel engines, hydraulic and bulk tank filtration—plus exhaust system components. Distributors can now order directly with a secure login that provides access to all your account information—including past orders—so you can simply re-order with a click.

Shop.donaldson.com makes ordering replacement filters easier than easy so you can keep your business moving.

Shop for filters the easier way at
shop.donaldson.com

Global Presence with a Local Touch

At Donaldson, we've built a strong, flexible and responsive distribution network to serve our customers around the world.

Localized Manufacturing – It starts with 30+ manufacturing locations around the world – producing most filters in the regions where they're used.

Primary Distribution Centers – Filters then move to our regional warehouses and distribution center hubs – meaning the filters you need are never far away.

Logistics – We work with a network of transportation and logistics companies, consolidators and cross-docking facilities to deliver products to distribution partners quickly and efficiently.

Distribution Partners – We've built one of the largest, strongest and most responsive distributor networks in the filter industry – meaning you can find the filters and support you need, nearly anywhere in the world.



Finding your Donaldson filter online has never been easier.

DISCOVER.

Go online to donaldson.com to learn which filter you need.

DECIDE.

Finding filters is easier than easy at shop.donaldson.com.



Donaldson Company, Inc.
Minneapolis, MN

shop.donaldson.com
donaldson.com

North America 800-374-1374
Mexico, Latin America &
Caribbean 52-449-910-6150
Brazil 55-11-4894-6340
Europe 32-16-38-3811
South Africa 27-11-997-6000

South East Asia 65-6311-7373
Greater China 852-2405-8388
Japan 81-42-540-4112
Korea 82-2-517-3333
Australia 61-02-4350-2033
India 91-124-2290060

Catalog No. F112100 ENG (04/26)

©2026 Donaldson Company, Inc. All rights reserved. Donaldson Company, Inc. reserves the right to change or discontinue any model or specification at any time and without notice. Printed in the U.S.A.